

Instructions

DeviceNet Card

WSIQ-COM-DN

Contents

1	Warnings.....	2
2	Important User Information.....	2
3	Installation.....	2
4	Configuration.....	3
5	DeviceNet Polled I/O Structure.....	4
6	Trip Codes.....	6
7	Parameter Object.....	8
8	Specifications.....	8

Product Compatibility

The DeviceNet Card is suitable for use with WSB and WSIQ soft starters.

Disclaimer

The examples and diagrams in this manual are included solely for illustrative purposes. The information contained in this manual is subject to change at any time and without prior notice. In no event will responsibility or liability be accepted for direct, indirect or consequential damages resulting from the use or application of this equipment.

1 Warnings



WARNING

For your safety, isolate the soft starter from mains voltage before attaching or removing accessories.



WARNING

Inserting foreign objects or touching the inside of the starter while the expansion port cover is open may endanger personnel, and can damage the starter.

2 Important User Information

Observe all necessary safety precautions when controlling the soft starter remotely. Alert personnel that machinery may start without warning.

It is the installer's responsibility to follow all instructions in this manual and to follow correct electrical practice.

Use all internationally recognised standard practice for RS-485 communications when installing and using this equipment.

3 Installation

3.1 Installation Procedure

1. Push a small flat-bladed screwdriver into the slot in the centre of the expansion port cover, and ease the cover away from the starter.
2. Line up the card with the expansion port. Gently push the card along the guide rails until it clicks into the starter.

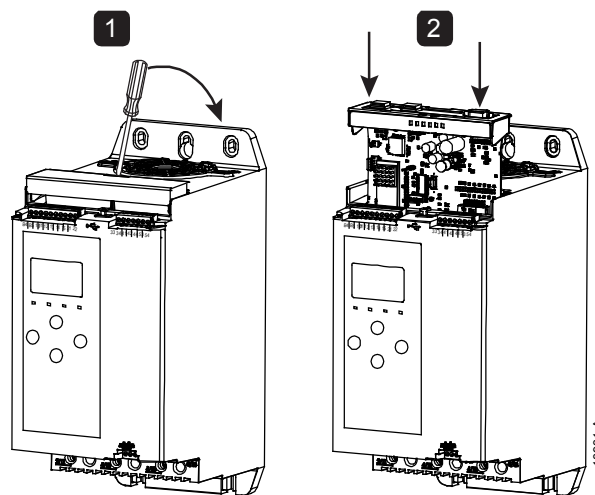

3.2 Connecting to the Network

After the card is in place, field wiring can be connected via the 5-way connector plug. The DeviceNet Card is powered via the connector.

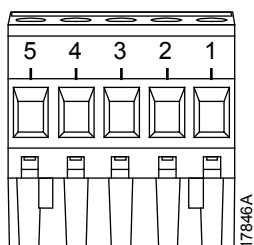

Pin	Function
5	V +
4	CAN_H
3	SHIELD
2	CAN_L
1	V -

**CAUTION**

Network designs must decrease the maximum allowable cumulative dropline length by 400 mm for every device installed on the network. Failure to do so may result in network communication errors and decreased reliability.

Example: ODVA specifies a maximum cumulative dropline length of 156 m on a network operating at 125 kb/s. If six devices were installed on this network, the total cumulative dropline length would need to be decreased to 153.6 m.

3.3 Feedback LEDs**Module and Network LEDs**

The Module LED indicates the condition of the power supply and device operation. The Network LED indicates status of the communication link between the DeviceNet Card and the network Master.

LED	State	Description
Module	Off	Network power off
	Green	Normal operation
	Red	Unrecoverable fault
	Red/Green flashing	Self Test mode
Network	Off	Duplicate MAC ID test has not been completed
	Green flashing	Online but no connection with Master
	Green	Online and allocated to a Master
	Red flashing	One or more timed out I/O connections
	Red	Failed communication between device and Master
	Red/Green flashing	Communication faulted and received an Identity communication faulted request

4 Configuration

The DeviceNet Card is a Group 2 slave device, using a predefined master/slave connection set. I/O data is produced and consumed using polled I/O messaging. The soft starter must be added to the DeviceNet manager project using the EDS file and configuration/management software tool. This file is available from www.worldwideelectric.net. In order to operate successfully, the correct EDS file must be used. An on-screen graphics bitmap file (device.bmp) is also available.

4.1 DeviceNet Network Settings

Network communication parameters for the card must be set via the soft starter. For details on how to configure the soft starter, refer to the soft starter user manual.

Parameter	Parameter name	Description
11E	<i>Devicenet Address</i>	Sets the DeviceNet network address for the soft starter.
11F	<i>Devicenet Baud Rate</i>	Selects the baud rate for DeviceNet communications.

4.2 Enabling Network Control

The soft starter will only accept commands from the DeviceNet Card if parameter 1A *Command Source* is set to 'Network'.



NOTE

If the reset input is active, the starter will not operate. If a reset switch is not required, fit a link across terminals 10, 11 on the soft starter.

5 DeviceNet Polled I/O Structure

Once the EDS file has been loaded, the DeviceNet Card must be added to the scanner list with parameters shown in the following table:

Parameter	Value
I/O connection type	Polled
Poll receive size	14 bytes
Poll transmit size	2 bytes

Once the soft starter, device and Master have been set up, configured and powered up, the Master will transmit 2 bytes of data to the device and receive 14 bytes of data from the device.

Master > Slave polled I/O output data is as follows:

Byte	Bit	Function
0	0	0 = Stop command 1 = Start command
	1	0 = Enable Start or Stop command 1 = Quick Stop (ie coast to stop) and disable Start command
	2	0 = Enable Start or Stop command 1 = Reset command and disable Start command
	3 to 7	<i>Reserved</i>
1	0 to 1	0 = Use soft starter remote input to select motor set 1 = Use primary motor set when starting ¹ 2 = Use secondary motor set when starting ¹ 3 = <i>Reserved</i>
	2 to 7	<i>Reserved</i>

¹ Ensure that the programmable input is not set to Motor Set Select before using this function.

Slave > Master polled I/O input data is as follows:

Byte	Bit	Function	Value
0	0	Trip	1 = Tripped
	1	Warning	1 = Warning
	2	Running	0 = Unknown, Not ready, Ready to start or Tripped 1 = Starting, Running, Stopping or Jogging
	3	<i>Reserved</i>	

Byte	Bit	Function	Value
	4	Ready	0 = Start or stop command not acceptable 1 = Start or stop command acceptable
	5	Control from Net	1 = Always except in Program mode
	6	Local/Remote	0 = Local control 1 = Remote control
	7	At reference	1 = Running (full voltage at the motor)
1	0 to 7	Status	0 = Unknown (menu open) 2 = Not ready (restart delay or thermal delay) 3 = Ready to start (including warning state) 4 = Starting or Running 5 = Stopping 7 = Tripped 8 = Jog forward 9 = Jog reverse
2	0 to 7	Trip/Warning code	Refer to <i>Trip Codes</i> on page 6
3	0	Initialised	1 = Phase sequence bit is valid (bit 1) after first start
	1	Phase sequence	1 = Positive phase sequence
	2 to 7	<i>Reserved</i>	
4 ¹	0 to 7	Motor current (low byte)	Current (A)
5 ¹	0 to 7	Motor current (high byte)	
6	0 to 7	Current %FLC (low byte)	Current as a percentage of soft starter FLC setting (%)
7	0 to 7	Current %FLC (high byte)	
8	0 to 7	% Motor 1 temperature	Motor thermal model (%)
9	0 to 7	<i>Reserved</i>	
10	0 to 7	% Power factor	Percentage power factor (100% = power factor of 1)
11	0 to 7	<i>Reserved</i>	
12	0 to 7	<i>Reserved</i>	
13	0 to 3	Digital Input state	For all inputs, 0 = open, 1 = closed (shorted) 0 = Start/Stop 1 = <i>Reserved</i> 2 = Reset 3 = Input A 4 = Input B
	4 to 7	<i>Reserved</i>	

¹ For models WSx-0064BP and smaller this value will be 10 times greater than the value displayed on the keypad.

6 Trip Codes

Code	Trip Type
0	No trip
11	Input A trip
20	Motor overload
21	Heatsink overtemperature
23	L1 phase loss
24	L2 phase loss
25	L3 phase loss
26	Current imbalance
27	Ground fault
28	Instantaneous overcurrent
29	Undercurrent
50	Power loss
54	Phase sequence
55	Frequency
60	Unsupported option (function not available in inside delta)
61	FLC too high
62	Parameter out of range
70	Miscellaneous
75	Motor thermistor
101	Excess start time
102	Motor connection
104	Internal fault x (where x is the fault code detailed in the table below)
105	Bypass fail (bypass contactor)
110	Input B trip
113	Starter communication (between device and soft starter)
114	Network communication (between device and network)
115	L1-T1 shorted
116	L2-T2 shorted
117	L3-T3 shorted
118	Motor 2 overload
119	Bypass overload
120	SCR overtemperature
121	Battery/clock
122	Thermistor circuit
132	Analog input trip

6.1 Internal Fault x

The table below details the internal fault code associated with trip code 104.

Internal fault	Message displayed on the keypad
70 ~ 72	Current Read Err Lx
73	ATTENTION! Remove Mains Volts
74 ~ 76	Motor Connection Tx
77 ~ 79	Firing Fail Px
80 ~ 82	VZC Fail Px
83	Low Control Volts
84 ~ 98	Internal fault X Contact your local supplier with the fault code (X).

7 Parameter Object

The DeviceNet Card supports parameter objects through explicit messaging. Soft starter parameters can be uploaded (written) and downloaded (read) using DeviceNet management software. When the DeviceNet Card is powered up, it automatically obtains parameter information from the soft starter.

Detail	Value (Hex)	Comment
Class	0F	Parameter object address
Instance	1 ~ xxx	xxx = maximum soft starter parameter number
Attribute ID	01	Always 0x01
Get Service	0E	Read single soft starter parameter value
Set Service	10	Write single soft starter parameter value

8 Specifications

Connections

Network 5-way male and unpluggable female connector (supplied)
 Maximum cable size 2.5 mm²

Settings

Address range 0 ~ 63
 Data rate 125 kB, 250 kB, 500 kB

Power

Consumption
 steady state 19 mA @ 25 VDC
 31 mA @ 11 VDC
 inrush (at 24 VDC) 1.8 A maximum for 2 ms
 Galvanically isolated

Certification

CE EN 60947-4-2
 RoHS Compliant with EU Directive 2011/65/EU
 ODVA 



7 1 0 - 1 8 8 9 1 - 0 0 A