

INSTRUCTIONS

DEVICENET MODULE

for use with WSIQ2/WSE

WorldWide Electric Corporation
Phone: 1-800-808-2131
Fax: 1-800-711-1616
www.worldwideelectric.net

Product Compatibility

This communications module is suitable for use with WSIQ2 and WSE soft starters.

Product description	Soft starter name
Compact soft starter	WSE
Advanced starter	WSIQ2

The following functions are only available with WSIQ2 soft starters:
parameter management, dual motor control, digital inputs, jog, current measurement in amperes, power information, warnings.

Parameter Management

Parameter lists vary according to the model and version of soft starter.

Refer to the relevant soft starter literature for a complete parameter list.

For the latest manuals and software, please visit our website.

Contents

1	Disclaimer	1
2	Important User Information	1
3	Installation	2
4	Configuration.....	3
5	Adjustment	3
6	Connection	4
7	LEDs.....	5
8	DeviceNet Polled I/O Structure.....	5
9	Trip Codes	7
10	Parameter Object.....	8
11	Specifications.....	9

1 Disclaimer

The examples and diagrams in this manual are included solely for illustrative purposes. The information contained in this manual is subject to change at any time and without prior notice. In no event will responsibility or liability be accepted for direct, indirect or consequential damages resulting from the use or application of this equipment.

2 Important User Information

Observe all necessary safety precautions when controlling the soft starter remotely. Alert personnel that machinery may start without warning.

It is the installer's responsibility to follow all instructions in this manual and to follow correct electrical practice.

3 Installation



CAUTION

Remove mains and control voltage from the soft starter before attaching or removing accessories. Failure to do so may damage the equipment.

1. Remove control power and mains supply from the soft starter.
2. Fully pull out the top and bottom retaining clips on the module. [A]
3. Line up the module with the comms port slot. [B]
4. Push in the top and bottom retaining clips to secure the module to the starter. [C]
5. Set the DeviceNet Module Node Address (MAC ID) and Data Rate.
6. Apply control power to the soft starter.
7. Insert the network connector into the module and power up the DeviceNet network.

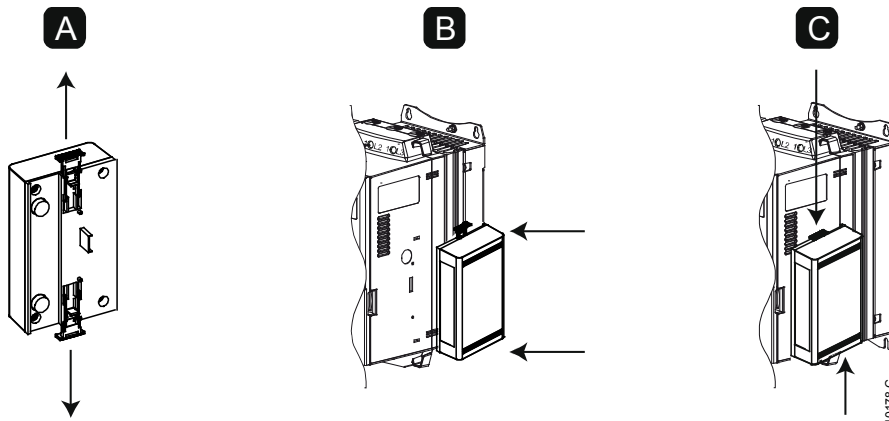

CAUTION

Network designs must decrease the maximum allowable cumulative dropline length by 400 mm for every device installed on the network. Failure to do so may result in network communication errors and decreased reliability.

Example: ODVA specifies a maximum cumulative dropline length of 156 m on a network operating at 125 kb/s. If six devices were installed on this network, the total cumulative dropline length would need to be decreased to 153.6 m.

Remove the module using the following procedure:

1. Take the module off-line.
2. Disconnect all external wiring from the module.
3. Remove control power and mains supply from the soft starter.
4. Fully pull out the top and bottom retaining clips on the module. [A]
5. Pull the module away from the soft starter.

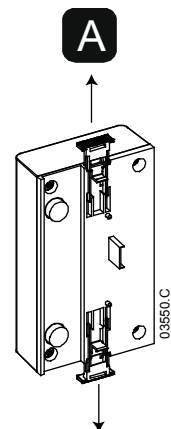

4 Configuration

The DeviceNet Module is a Group 2 slave device, using a predefined master/slave connection set. I/O data is produced and consumed using polled I/O messaging.

The soft starter must be added to the DeviceNet manager project using the EDS file and configuration/management software tool. In order to operate successfully, the correct EDS file must be used. An on-screen graphics bitmap file (device.bmp) is also available. Contact your local supplier for further information.

5 Adjustment

Changes to the rotary switch settings take effect when the DeviceNet network is next powered up.

The factory default settings for the rotary adjustment switches are:

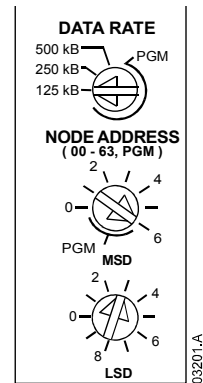

NOTE

The Data Rate and Node Address (MAC ID) must be set locally on the module. These cannot be set using DeviceNet management software.

When the Data Rate and MSD Node Address (MAC ID) rotary switches are set on PGM position, the module uses the previously used valid on-line Data Rate and Node Address (MAC ID).

6 Connection

Compact soft starter		Advanced soft starter	
1	Soft starter A1, 02: Stop	1	Soft starter (Remote mode) C31, C32: Stop input C41, C42: Reset input
2	DeviceNet Module	2	DeviceNet Module
3	Standard connection onto DeviceNet network	3	Standard connection onto DeviceNet network

Compact soft starter:

- For the soft starter to accept fieldbus commands, a link must be fitted across terminals A1-02 on the soft starter.

Advanced soft starter:

- Control via the fieldbus communication network is always enabled in local control mode, and can be enabled or disabled in remote control mode (parameter 6R *Comms in Remote*). Refer to the soft starter user manual for parameter details.
- Input links are required across the stop and reset inputs if the soft starter is being operated in Remote mode. In Local mode, links are not required.

7 LEDs

The Module LED indicates the condition of the power supply and device operation.

The Network LED indicates status of the communication link between the device and the network Master.

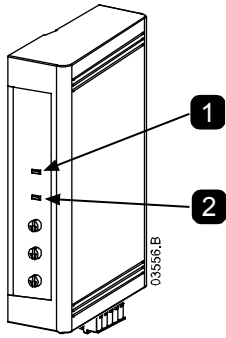

LED name	LED Status	Description
Module	Off	Network power off
	Green	Normal operation
	Red	Unrecoverable fault
	Red/Green flashing	Self Test mode
Network	Off	Duplicate MAC ID test has not been completed
	Green flashing	Online but no connection with Master
	Green	Online and allocated to a Master
	Red flashing	One or more timed out I/O connections
	Red	Failed communication between device and Master
	Red/Green flashing	Communication faulted and received an Identity communication faulted request



NOTE

When a communications failure occurs, the soft starter may trip if the Communication Timeout parameter for the network is set greater than zero. When communication is restored, the soft starter must be reset.

8 DeviceNet Polled I/O Structure

Once the EDS file has been loaded, the device must be added to the scanner list with parameters shown in the following table:

Parameter	Value
I/O connection type	Polled
Poll receive size	14 bytes
Poll transmit size	2 bytes

Once the soft starter, device and Master have been set up, configured and powered up, the Master will transmit 2 bytes of data to the device and receive 14 bytes of data from the device.

Master > Slave polled I/O output data is as follows:

Byte	Bit	Function
0	0	0 = Stop command 1 = Start command
	1	0 = Enable Start or Stop command 1 = Quick Stop (ie coast to stop) and disable Start command
	2	0 = Enable Start or Stop command 1 = Reset command and disable Start command
	3 to 7	Reserved

Byte	Bit	Function
1	0 to 1	0 = Use soft starter remote input to select motor set 1 = Use primary motor set when starting ¹ 2 = Use secondary motor set when starting ¹ 3 = <i>Reserved</i>
	2 to 7	<i>Reserved</i>

¹ Ensure that the programmable input is not set to Motor Set Select before using this function.

Slave > Master polled I/O input data is as follows:

Byte	Bit	Function	Value
0	0	Trip	1 = Tripped
	1	Warning	1 = Warning
	2	Running	0 = Unknown, Not ready, Ready to start or Tripped 1 = Starting, Running, Stopping or Jogging
	3	<i>Reserved</i>	
	4	Ready	0 = Start or stop command not acceptable 1 = Start or stop command acceptable
	5	Control from Net	1 = Always except in Program mode
	6	Local/Remote	0 = Local control 1 = Remote control
	7	At reference	1 = Running (full voltage at the motor)
1	0 to 7	Status	0 = Unknown (menu open) 2 = Not ready (restart delay or thermal delay) 3 = Ready to start (including warning state) 4 = Starting or Running 5 = Soft stopping 7 = Tripped 8 = Jog forward 9 = Jog reverse
2	0 to 7	Trip/Warning code	See <i>Trip Codes</i> on page 7
3	0	Initialised	1 = Phase sequence bit is valid (bit 1) after first start
	1	Phase sequence	1 = Positive phase sequence
	2 to 7	<i>Reserved</i>	
4 ¹	0 to 7	Motor current (low byte)	Current (A)
5 ¹	0 to 7	Motor current (high byte)	
6	0 to 7	Current %FLC (low byte)	Current as a percentage of soft starter FLC setting (%)
7	0 to 7	Current %FLC (high byte)	
8	0 to 7	% Motor 1 temperature	Motor 1 thermal model (%)
9	0 to 7	% Motor 2 temperature	Motor 2 thermal model (%)
10	0 to 7	% Power factor	Percentage power factor (100% = power factor of 1)
11	0 to 7	Power (low byte)	Power low byte, scaled by power scale

Byte	Bit	Function	Value
12	0 to 3	Power (high nibble)	Power high nibble, scaled by power scale
	4 to 5	Power scale	0 = Multiply power by 10 to get W 1 = Multiply power by 100 to get W 2 = Power (kW) 3 = Multiply power by 10 to get kW
	6 to 7	<i>Reserved</i>	
13	0 to 3	Digital input state	For all inputs, 0 = open, 1 = closed (shorted) 0 = Start 1 = Stop 2 = Reset 3 = Input A 4 = Input B 5 = Input C (if fitted) 6 = Input D (if fitted) 7 = <i>Reserved</i>
	4 to 7	<i>Reserved</i>	

¹ For models 0053B and smaller this value will be 10 times greater than the value displayed on the keypad.

9 Trip Codes

Code	Trip Type
0	No trip
11	Input A trip
20	Motor overload
21	Heatsink overtemperature
23	L1 phase loss
24	L2 phase loss
25	L3 phase loss
26	Current imbalance
27	Ground fault
28	Instantaneous overcurrent
29	Undercurrent
50	Power loss
54	Phase sequence
55	Frequency
60	Unsupported option (function not available in inside delta)
61	FLC too high
62	Parameter out of range
70	Miscellaneous
75	Motor thermistor
101	Excess start time
102	Motor connection
104	Internal fault x (where x is the fault code detailed in the table below)
110	Input Trip B

Code	Trip Type
113	Starter communication (between device and soft starter)
114	Network communication (between device and network)
115	L1-T1 shorted
116	L2-T2 shorted
117	L3-T3 shorted
118	Motor 2 overload
119	Time-overcurrent (Bypass overload)
121	Battery/clock
122	Thermistor circuit
123	RTD/PT100 A
124	RTD/PT100 B
125	RTD/PT100 C
126	RTD/PT100 D
127	RTD/PT100 E
128	RTD/PT100 F
129	RTD/PT100 G
130	RTD/PT100 X Cirtc
132	Analog input trip

9.1 Internal Fault X

The table below details the internal fault code associated with trip code 104.

Internal fault	Message displayed on the keypad
70 ~ 72	Current Read Err Lx
73	ATTENTION! Remove Mains Volts
74 ~ 76	Motor Connection Tx
77 ~ 79	Firing Fail Px
80 ~ 82	VZC Fail Px
83	Low Control Volts
84 ~ 98	Internal fault X Contact your local supplier with the fault code (X).

10 Parameter Object

The device supports parameter objects through explicit messaging. Soft starter parameters can be uploaded (written) and downloaded (read) using DeviceNet management software. When the device is powered up, it automatically obtains parameter information from the soft starter.

Detail	Value (Hex)	Comment
Class	0F	Parameter object address
Instance	1 ~ xxx	xxx = maximum soft starter parameter number
Attribute ID	01	Always 0x01
Get Service	0E	Read single soft starter parameter value
Set Service	10	Write single soft starter parameter value

11 Specifications

- **Enclosure**

Dimensions 40 mm (W) x 166 mm (H) x 90 mm (D)
 Weight 250 g
 Protection IP20

- **Mounting**

Spring-action plastic mounting clips (x 2)

- **Connections**

Soft starter 6-way pin assembly
 Network 5-way male and unpluggable female connector (supplied)
 Maximum cable size 2.5 mm²
 Contacts Gold flash

- **Settings**

Node address (MAC ID)

Setting Rotary switches
 Range 0 ~ 63 (63, factory default)

Data rate

Setting Rotary switches
 Options 125 kB, 250 kB, 500 kB (125 kB, factory default)

- **Power**

Consumption

steady state 19 mA @ 25 VDC
 31 mA @ 11 VDC
 inrush (at 24 VDC) 1.8 A maximum for 2 ms

Galvanically isolated

- **Certification**

CE EN 60947-4-2
 ODVA 