



# WSIQ USER MANUAL



WorldWide Electric Corporation  
Phone: 1-800-808-2131  
Fax: 1-800-711-1616  
[www.worldwideelectric.net](http://www.worldwideelectric.net)



## Contents

<b>1</b>	<b>About This Manual</b> .....	<b>4</b>
1.1	Disclaimer .....	4
<b>2</b>	<b>Caution Statements</b> .....	<b>5</b>
2.1	Electrical shock risk.....	5
2.2	Unexpected Operation .....	6
2.3	Avertissements à l'attention des clients canadiens .....	7
<b>3</b>	<b>System Design</b> .....	<b>9</b>
3.1	Feature List .....	9
3.2	Model Code.....	10
3.3	Model Selection.....	10
3.4	Current Ratings.....	11
3.5	Dimensions and Weights .....	14
3.6	Physical Installation.....	15
3.7	Accessories.....	15
3.8	Main Contactor.....	16
3.9	Circuit Breaker .....	16
3.10	Power Factor Correction .....	16
3.11	Short Circuit Protection Devices (SCPD) .....	17
3.12	IEC Coordination with Short Circuit Protection Devices .....	18
3.13	UL Coordination with Short Circuit Protection Devices .....	19
3.14	Fuse Selection for Type 2 Coordination .....	22
3.15	Specifications .....	23
3.16	Disposal Instructions .....	24
<b>4</b>	<b>Installation</b> .....	<b>25</b>
4.1	Command Source .....	25
4.2	Basic Setup.....	25
4.3	Inputs .....	26
4.4	Outputs .....	28
4.5	Control Voltage .....	29
4.6	Power Terminations .....	30
4.7	Typical Installation.....	32
4.8	Quick Setup .....	33
<b>5</b>	<b>Setup Tools</b> .....	<b>34</b>
5.1	Set Date and Time .....	34
5.2	Command Source .....	34
5.3	Commissioning.....	34
5.4	Run simulation .....	34
5.5	Load/Save Settings .....	35
5.6	USB Save & Load .....	36
5.7	Auto-Start/Stop.....	37
5.8	Network Address.....	38
5.9	Digital I/O State .....	38
5.10	Analog I/O State.....	39

5.11	Serial Number & Rating .....	39
5.12	Software Versions .....	39
5.13	Thermistor Reset.....	39
5.14	Reset Thermal Model.....	39
<b>6</b>	<b>Logs .....</b>	<b>40</b>
6.1	Event Log.....	40
6.2	Counters .....	40
<b>7</b>	<b>Keypad and Feedback .....</b>	<b>41</b>
7.1	The Keypad.....	41
7.2	Remote Keypad .....	42
7.3	Starter status LEDs .....	42
7.4	Displays .....	42
<b>8</b>	<b>Operation .....</b>	<b>44</b>
8.1	Start, Stop and Reset Commands.....	44
8.2	Command Override.....	44
8.3	Scheduled Start/Stop .....	44
8.4	PowerThrough.....	44
8.5	Emergency Mode .....	45
8.6	Auxiliary Trip .....	45
8.7	Typical Control Methods .....	46
8.8	Soft Start Methods .....	47
8.9	Stop Methods.....	49
8.10	Jog Operation.....	53
8.11	Inside Delta Operation .....	54
8.12	Secondary Motor Set .....	54
<b>9</b>	<b>Programmable Parameters .....</b>	<b>55</b>
9.1	Programming Menu.....	55
9.2	Altering Parameter Values .....	55
9.3	Adjustment Lock.....	55
9.4	Parameter List.....	55
9.5	1 Motor Details .....	61
9.6	2 Motor Start/Stop .....	62
9.7	3 Motor Start/Stop-2.....	64
9.8	4 Auto-Start/Stop.....	67
9.9	5 Protection Levels.....	70
9.10	6 Protection Action .....	71
9.11	7 Inputs .....	74
9.12	8 Relay Outputs .....	76
9.13	9 Analog Output .....	78
9.14	10 Display .....	79
9.15	11 Communications Card.....	81
9.16	12 Pump Input Configuration .....	84
9.17	13 Flow Protection .....	86
9.18	14 Pressure Protection.....	87

---

9.19	15 Pressure Control .....	88
9.20	16 Depth Protection .....	89
9.21	17 Thermal Protection.....	89
9.22	20 Advanced .....	90
<b>10</b>	<b>Application Examples.....</b>	<b>91</b>
10.1	Smart Card - Pump Control and Protection.....	91
10.2	Smart Card - Level Controlled Pump Activation .....	93
<b>11</b>	<b>Troubleshooting.....</b>	<b>94</b>
11.1	Protection Responses .....	94
11.2	Trip Messages.....	94
11.3	General Faults.....	100

# 1 About This Manual

**WARNING**

Indicates a hazard that may cause personal injury or death.

**CAUTION**

Indicates a hazard that may damage the equipment or installation.

**NOTE**

Provides helpful information.

## 1.1 Disclaimer

The examples and diagrams in this manual are included solely for illustrative purposes.

The information contained in this manual is subject to change at any time and without prior notice. In no event will responsibility or liability be accepted for direct, indirect or consequential damages resulting from the use or application of this equipment.

## 2 Caution Statements

Caution Statements cannot cover every potential cause of equipment damage but can highlight common causes of damage. It is the installer's responsibility to read and understand all instructions in this manual prior to installing, operating or maintaining the equipment, to follow good electrical practice including applying appropriate personal protective equipment and to seek advice before operating this equipment in a manner other than as described in this manual.



### NOTE

The WSIQ soft starter is not user serviceable. The unit should only be serviced by authorised service personnel. Unauthorised tampering with the unit will void the product warranty.

### 2.1 Electrical shock risk



#### WARNING – ELECTRICAL SHOCK RISK

The voltages present in the following locations can cause severe electric shock and may be lethal:

- AC supply cables and connections
- Output cables and connections
- Many internal parts of the starter

The AC supply must be disconnected from the starter using an approved isolation device before any cover is removed from the starter or before any servicing work is performed.



#### SHORT CIRCUIT

The WSIQ is not short circuit proof. After severe overload or short circuit, the operation of the WSIQ should be fully tested by an authorised service agent.



#### GROUNDING AND BRANCH CIRCUIT PROTECTION

It is the responsibility of the user or person installing the WSIQ to provide proper grounding and branch circuit protection according to local electrical safety codes.



#### FOR YOUR SAFETY

- § The STOP function of the soft starter does not isolate dangerous voltages from the output of the starter. The soft starter must be disconnected by an approved electrical isolation device before accessing electrical connections.
- § Soft starter protection features apply to motor protection only. It is the user's responsibility to ensure safety of personnel operating machinery.
- § The soft starter is a component designed for integration within an electrical system; it is therefore the responsibility of the system designer/user to ensure the system is safe and designed to comply with relevant local safety standards.

## 2.2 Unexpected Operation



### **WARNING – ACCIDENTAL STARTS**

In some installations, accidental starts may pose an increased risk to safety of personnel or damage to the machines being driven. In such cases, it is recommended that the power supply to the soft starter is fitted with an isolating switch and a circuit-breaking device (eg power contactor) controllable through an external safety system (eg emergency stop, fault detector).



### **WARNING – STARTER MAY START OR STOP UNEXPECTEDLY**

The WSIQ will respond to control commands from various sources, and could start or stop unexpectedly. Always disconnect the soft starter from mains voltage before accessing the starter or load.



### **WARNING – DISCONNECT MAINS BEFORE ACCESSING STARTER OR LOAD**

The soft starter has built-in protections which can trip the starter in the event of faults and thus stop the motor. Voltage fluctuations, power cuts and motor jams may also cause the motor to trip.

The motor could restart after the causes of shutdown are rectified, which may be dangerous for personnel. Always disconnect the soft starter from mains voltage before accessing the starter or load.



### **CAUTION – MECHANICAL DAMAGE FROM UNEXPECTED RESTART**

The motor could restart after the causes of shutdown are rectified, which may be dangerous for certain machines or installations. In such cases, it is essential that appropriate arrangements are made against restarting after unscheduled stops of the motor.

## 2.3 Avertissements à l'attention des clients canadiens



### AVERTISSEMENT

L'icône AVERTISSEMENT ci-contre signale les informations concernant des risques pouvant entraîner des blessures graves, voire mortelles. Pour votre sécurité, veuillez consulter les avertissements sur cette page ou demander une copie du présent manuel en français auprès de votre distributeur local.



### AVERTISSEMENT – RISQUE DE CHOC ÉLECTRIQUE

Les zones suivantes sont soumises à des tensions pouvant provoquer des risques de chocs électriques graves, voire mortels :

- Raccordement et câbles d'alimentation AC
- Câbles et raccordements de sortie
- De nombreuses pièces internes du démarreur

L'alimentation AC doit être déconnectée du démarreur au moyen d'un dispositif d'isolation agréé avant de retirer des capots ou avant de procéder à des travaux d'entretien.



### PAR SÉCURITÉ

- § La fonction STOP du démarreur progressif n'isole pas des tensions dangereuses de la sortie du démarreur. Le démarreur progressif doit être déconnecté par un dispositif d'isolement électrique approprié avant d'accéder aux connexions électriques.
- § Les fonctions de protection du démarreur progressif ne concernent que la protection du moteur. Il relève de la responsabilité de l'utilisateur d'assurer la sécurité des personnes travaillant sur les machines.
- § Le démarreur progressif est un appareil conçu pour s'intégrer dans un système électrique ; il relève donc de la responsabilité du concepteur ou de l'utilisateur de veiller à ce que ce système soit sûr et conçu selon les normes de sécurité locales en vigueur.



### AVERTISSEMENT – DÉMARRAGES ACCIDENTELS

Dans certaines installations, des démarrages accidentels peuvent provoquer un risque supplémentaire pour la sécurité des personnes ou endommager les machines contrôlées. Dans de tels cas, il est recommandé de doter l'alimentation du démarreur progressif d'un interrupteur d'isolement et d'un coupe-circuit (par exemple, un disjoncteur) contrôlable à partir d'un système de sécurité externe (par exemple, un arrêt d'urgence, un détecteur de défaut).



### AVERTISSEMENT – LE DÉMARREUR PEUT DÉMARRER OU S'ARRÊTER À TOUT MOMENT

Le WSIQ répond aux commandes de contrôle de différentes origines et peut par conséquent démarrer ou s'arrêter à tout moment. Toujours déconnecter le démarreur de la tension secteur avant d'accéder au démarreur ou à la charge.

**AVERTISSEMENT – DÉCONNECTER L'ALIMENTATION PRINCIPALE AVANT D'ACCÉDER AU DÉMARREUR OU À LA CHARGE**

Le démarreur progressif comporte des protections intégrées qui peuvent déclencher des mises en sécurité dans l'éventualité de défauts et ainsi arrêter le moteur. Des fluctuations de tension, des coupures d'alimentation et des blocages du moteur peuvent produire des mises en sécurité de celui-ci.

Le moteur pourrait redémarrer une fois que les causes de l'arrêt ont été résolues, ce qui pourrait mettre en danger le personnel. Toujours déconnecter le démarreur de la tension secteur avant d'accéder au démarreur ou à la charge.

**AVERTISSEMENT**

Ne pas appliquer la tension du secteur au démarreur tant que tout le câblage n'est pas terminé.

**AVERTISSEMENT**

Toujours appliquer la tension de commande avant (ou en même temps que) la tension secteur.

**AVERTISSEMENT**

Lors du raccordement du WSIQ en connexion 6 fils, toujours installer un contacteur principal ou un disjoncteur magnéto-thermique à bobine de déclenchement.

## 3 System Design

### 3.1 Feature List

#### Streamlined setup process

- Configuration profiles for common applications
- Built-in metering and inputs/outputs

#### Easy to understand interface

- Multi-language menus and displays
- Descriptive option names and feedback messages
- Real-time performance graphs

#### Supports energy efficiency

- IE3 compatible
- 99% energy efficient when running
- Internal bypass
- Soft start technology avoids harmonic distortion

#### Extensive range of models

- 24 A to 580 A (nominal)
- 200 VAC to 525 VAC
- 380 VAC to 690 VAC
- Inside delta installation

#### Versatile starting and stopping options

- Adaptive Control
- Constant Current
- Current Ramp
- Timed voltage ramp soft stop
- Coast To Stop
- DC Brake
- Soft Brake

#### Customisable protection

- Motor overload
- Excess Start Time
- Undercurrent
- Overcurrent
- Current imbalance
- Input Trip
- Motor thermistor

#### Extensive input and output options

- Remote control inputs (2 x fixed, 2 x programmable)
- Relay outputs (1 x fixed, 2 x programmable)
- Analog output

#### Optional features for advanced applications

- Smart cards
- Communication options: DeviceNet, Ethernet/IP, Modbus RTU, Modbus TCP, Profibus, Profinet

### 3.2 Model Code

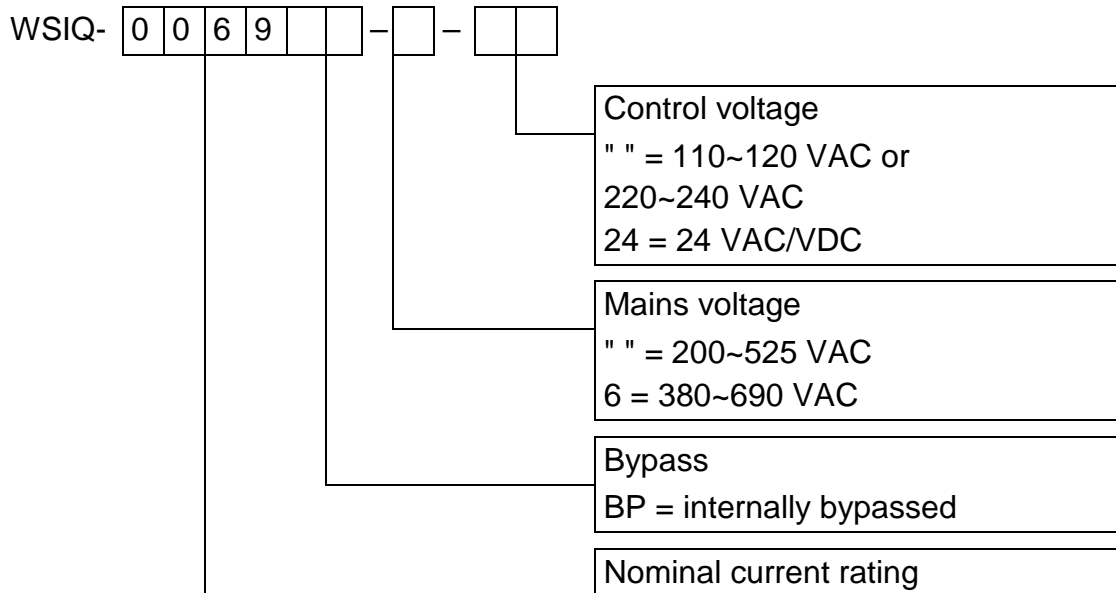

### 3.3 Model Selection

#### Starter sizing

The soft starter must be the correct size for the motor and the application.

Select a soft starter that has a current rating at least equal to the motor's full load current (nameplate) rating, at the start duty.

The soft starter's current rating determines the maximum motor size it can be used with. The soft starter's rating depends on the number of starts per hour, the length and current level of the start, and the amount of time the soft starter will be off (not passing current) between starts.

The soft starter's current rating is only valid when used in the conditions specified in the AC53b code - the soft starter may have a higher or lower current rating in different operating conditions.

### 3.4 Current Ratings

For operating conditions not covered by these ratings charts, download WorldWide Electric's free WORLDStart Select selection application, or contact your local supplier.

#### IEC ratings

- AC53b format

80 A : AC-53b 3.5 - 15 : 345

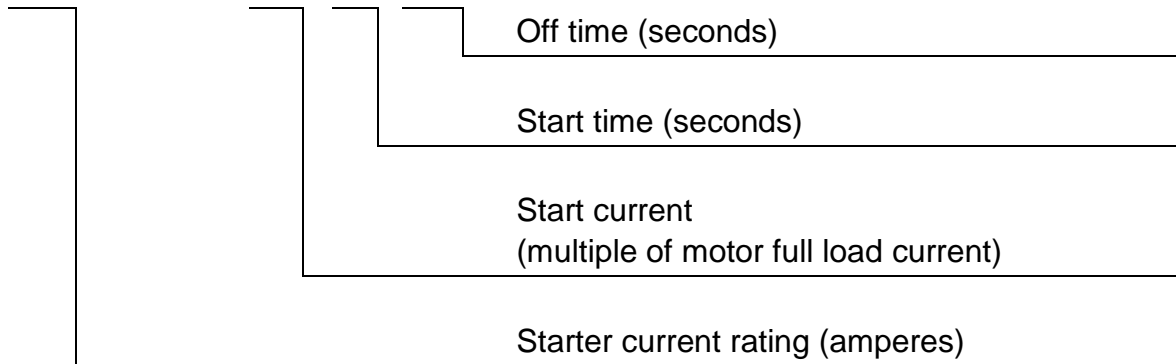

- Ratings

All ratings are calculated at altitude of 1000 metres and ambient temperature of 40 °C.

#### In-line installation

	3.0-10:350	3.5-15:345	4.0-10:350	4.0-20:340	5.0-5:355
WSIQ-0024BP	24	20	19	16	17
WSIQ-0042BP	42	34	34	27	32
WSIQ-0052BP	52	42	39	35	34
	3.0-10:590	3.5-15:585	4.0-10:590	4.0-20:580	5.0-5:595
WSIQ-0064BP	64	63	60	51	54
WSIQ-0069BP	69	69	69	62	65
WSIQ-0105BP	105	86	84	69	77
WSIQ-0115BP	115	108	105	86	95
WSIQ-0135BP	135	129	126	103	115
WSIQ-0184BP	184	144	139	116	127
WSIQ-0200BP	200	171	165	138	150
WSIQ-0229BP	229	194	187	157	170
WSIQ-0250BP	250	244	230	200	202
WSIQ-0352BP	352	287	277	234	258
WSIQ-0397BP	397	323	311	263	289
WSIQ-0410BP	410	410	410	380	400
WSIQ-0550BP	550	527	506	427	464
WSIQ-0580BP	580	579	555	470	508

**Inside delta installation**

	<b>3.0-10:350</b>	<b>3.5-15:345</b>	<b>4.0-10:350</b>	<b>4.0-20:340</b>	<b>5.0-5:355</b>
WSIQ-0024BP	36	30	28	24	25
WSIQ-0042BP	63	51	51	40	48
WSIQ-0052BP	78	63	58	52	51
	<b>3.0-10:590</b>	<b>3.5-15:585</b>	<b>4.0-10:590</b>	<b>4.0-20:580</b>	<b>5.0-5:595</b>
WSIQ-0064BP	96	94	90	76	81
WSIQ-0069BP	103	103	103	93	97
WSIQ-0105BP	157	129	126	103	115
WSIQ-0115BP	172	162	157	129	142
WSIQ-0135BP	202	193	189	154	172
WSIQ-0184BP	276	216	208	174	190
WSIQ-0200BP	300	256	247	207	225
WSIQ-0229BP	343	291	280	235	255
WSIQ-0250BP	375	366	345	300	303
WSIQ-0352BP	528	430	415	351	387
WSIQ-0397BP	595	484	466	394	433
WSIQ-0410BP	615	615	615	570	600
WSIQ-0550BP	825	790	759	640	696
WSIQ-0580BP	870	868	832	705	762

**NEMA motor ratings**

All ratings are calculated at altitude of 1000 metres and ambient temperature of 50 °C.

	<b>Light 300%, 10 s, 6 starts per hour</b>				<b>Normal 350%, 30 s, 4 starts per hour</b>				<b>Heavy 450%, 30 s, 4 starts per hour</b>			
	A	HP @230 VAC	HP @460 VAC	HP @575 VAC	A	HP @230 VAC	HP @460 VAC	HP @575 VAC	A	HP @230 VAC	HP @460 VAC	HP @575 VAC
WSIQ-0024BP	24	7.5	15	20	17	5	10	15	14	3	10	10
WSIQ-0042BP	42	15	30	40	28	10	20	25	22	7.5	15	20
WSIQ-0052BP	52	15	30	50	35	10	25	30	28	10	20	25
WSIQ-0064BP	64	20	50	60	52	15	30	40	40	10	25	30
WSIQ-0069BP	69	25	50	60	59	20	40	50	46	15	30	40
WSIQ-0105BP	100	30	75	100	77	25	50	60	52	15	40	50
WSIQ-0115BP	115	40	75	100	81	30	60	75	65	20	50	60
WSIQ-0135BP	135	50	100	125	99	30	75	100	77	25	60	75
WSIQ-0184BP	164	60	125	150	124	40	75	100	96	30	60	75
WSIQ-0200BP	200	75	150	200	131	50	100	125	104	40	75	100
WSIQ-0229BP	229	75	150	200	156	60	125	150	124	40	100	100
WSIQ-0250BP	250	100	200	250	195	75	150	200	156	60	125	150
WSIQ-0352BP	341	125	250	350	240	75	150	200	180	60	150	150
WSIQ-0397BP	389	150	300	400	261	100	200	250	203	75	150	200
WSIQ-0410BP	410	150	300	450	377	150	300	350	302	100	250	300
WSIQ-0550BP	550	200	450	500	414	150	350	450	321	125	250	300
WSIQ-0580BP	580	200	500	500	477	200	400	500	361	150	300	350

### 3.5 Dimensions and Weights

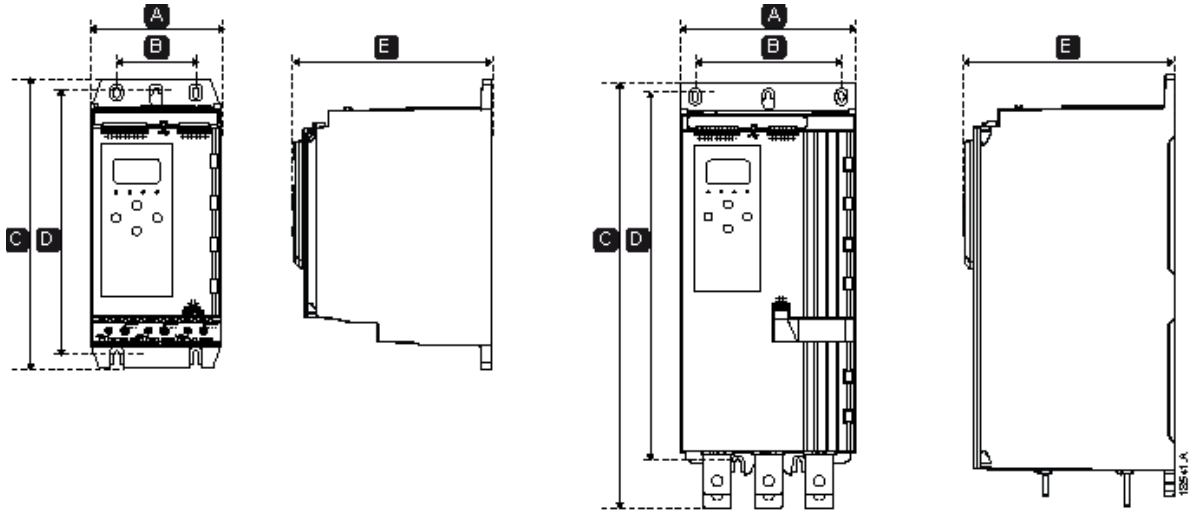

	Width mm (inch)		Height mm (inch)		Depth mm (inch)	Weight kg (lb)
	A	B	C	D	E	
WSIQ-0024BP	152 (6.0)	92 (3.6)	336 (13.2)	307 (12.1)	231 (9.1)	4.8
WSIQ-0042BP						(10.7)
WSIQ-0052BP						4.9
WSIQ-0064BP						(10.9)
WSIQ-0069BP						
WSIQ-0105BP						5.5
WSIQ-0115BP						(12.1)
WSIQ-0135BP						
WSIQ-0184BP	216 (8.5)	180 (7.1)	495 (19.5)	450 (17.7)	243 (9.6)	12.7
WSIQ-0200BP						(28.0)
WSIQ-0229BP						
WSIQ-0250BP						
WSIQ-0352BP			15.5			
WSIQ-0397BP			(34.2)			
WSIQ-0410BP						
WSIQ-0550BP			19.0			
WSIQ-0580BP			(41.9)			

### 3.6 Physical Installation

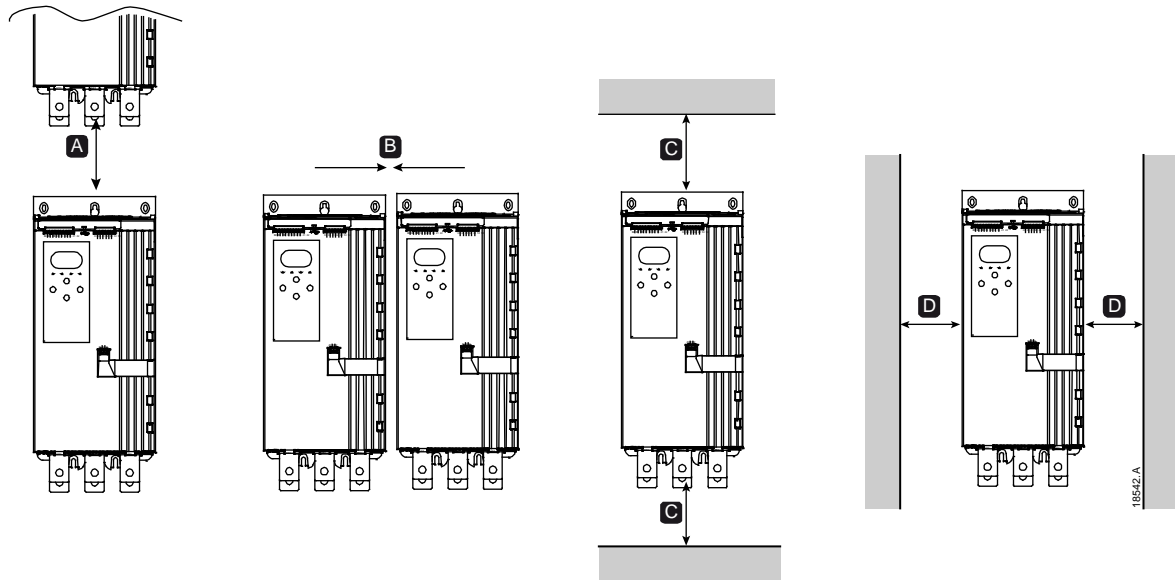

Between starters		Solid surfaces	
A	B	C	D
> 100 mm (3.9 inch)	> 10 mm (0.4 inch)	> 100 mm (3.9 inch)	> 10 mm (0.4 inch)

### 3.7 Accessories

#### Expansion Cards

The WSIQ offers expansion cards for users requiring additional inputs and outputs or advanced functionality. Each WSIQ can support a maximum of one expansion card.

- **Smart Card**

The smart card has been designed to support integration with pumping applications and provides the following additional inputs and outputs:

- 3 x digital inputs
- 3 x 4-20 mA transducer inputs
- 1 x RTD input
- 1 x USB-B port
- Remote keypad connector

- **Communication Expansion Cards**

WSIQ soft starters support network communication via easy-to-install communications expansion cards. Each communications card includes a remote keypad connector port.

Available protocols:

DeviceNet, Ethernet/IP, Modbus RTU, Modbus TCP, Profibus, Profinet.

#### Remote Keypad

WSIQ starters can be used with a remote keypad, mounted up to 3 metres away from the starter. Each expansion card includes a keypad connection port, or a dedicated keypad connector card is available.

### Finger Guard Kit

Finger guards may be specified for personnel safety. Finger guards fit over the soft starter terminals to prevent accidental contact with live terminals. Finger guards provide IP20 protection when used with cable of diameter 22 mm or greater.

Finger guards are compatible with models WSIQ-0184BP ~ WSIQ-0580BP.

### WORLDStart Visual Starter Management Software

WORLDStart Visual PC software can provide real-time or offline management of all WorldWide Electric soft starters.

- For real-time management in a network of up to 254 starters, WORLDStart Visual must connect to the WSIQ via a Modbus TCP or Modbus RTU card. WORLDStart can monitor, control and program the starter across the network.
- WORLDStart Visual can be used to program the WSIQ via the USB port on the pumping smart card.
- For offline management, a configuration file generated in WORLDStart Visual can be loaded into the starter via the USB port.

## 3.8 Main Contactor

A main contactor is recommended to protect the soft starter from voltage disturbances on the network, while stopped. Select a contactor with an AC3 rating greater than or equal to the full load current rating of the connected motor.

Use the main contactor output (33, 34) to control the contactor.



#### WARNING

When connecting the WSIQ in inside delta configuration, always install a main contactor or shunt trip circuit breaker.

## 3.9 Circuit Breaker

A shunt trip circuit breaker may be used instead of a main contactor to isolate the motor circuit in the event of a soft starter trip. The shunt trip mechanism must be powered from the supply side of the circuit breaker or from a separate control supply.

## 3.10 Power Factor Correction

If power factor correction is used, a dedicated contactor should be used to switch in the capacitors.

To use the WSIQ to control power factor correction, connect the PFC contactor to a programmable relay set to Run. When the motor reaches full speed, the relay will close and power factor correction will be switched in.



#### CAUTION

Power factor correction capacitors must be connected to the input side of the soft starter. Connecting power factor correction capacitors to the output side will damage the soft starter.

### 3.11 Short Circuit Protection Devices (SCPD)

Fuses may be installed to protect the soft starter or the installation.

#### Type 1 Coordination

Type 1 coordination requires that, in the event of a short circuit on the output side of a soft starter, the fault must be cleared without risk of injury to personnel. There is no requirement that the soft starter must remain operational after the fault.

HRC fuses (such as Ferraz/Mersen AJT fuses) can be used for Type 1 coordination according to IEC 60947-4-2 standard.

#### Type 2 Coordination

Type 2 coordination requires that in the event of a short circuit on the output side of a soft starter, the fault must be cleared without risk of injury to personnel or damage to the soft starter.

Semiconductor fuses for Type 2 circuit protection are additional to HRC fuses or MCCBs that form part of the motor branch circuit protection.



#### CAUTION

DC Brake: A high brake torque setting can result in peak currents up to motor DOL being drawn while the motor is stopping. Ensure protection fuses installed in the motor branch circuit are selected appropriately.



#### CAUTION

Integral solid state short circuit protection does not provide branch circuit protection. Branch circuit protection must be provided in accordance with the National Electrical Code and any additional local codes.

### 3.12 IEC Coordination with Short Circuit Protection Devices

These fuses were selected based on start current of 300% FLC for 10 seconds.

	Nominal Rating (A)	SCR I <sup>2</sup> T (A <sup>2</sup> S)	Type 1 coordination 480 VAC, 65 kA Bussmann NH fuse links	Type 2 coordination 690 VAC, 65 kA Bussmann DIN 43 653
WSIQ-0024BP	24	1150	40NHG000B	170M3010
WSIQ-0042BP	42	7200	63NHG000B	170M3013
WSIQ-0052BP	52		80NHG000B	
WSIQ-0064BP	64	15000	100NHG000B	170M3014
WSIQ-0069BP	69			
WSIQ-0105BP	105	80000	160NHG00B	170M3015
WSIQ-0115BP	115			
WSIQ-0135BP	135	125000		170M3016
WSIQ-0184BP	184	320000	250NHG2B	170M3020
WSIQ-0200BP	200		315NHG2B	
WSIQ-0229BP	229			
WSIQ-0250BP	250		170M3021	
WSIQ-0352BP	352	202000	355NHG2B	170M6009
WSIQ-0397BP	397		400NHG2B	
WSIQ-0410BP	410	320000	425NHG2B	170M6010
WSIQ-0550BP	550	781000	630NHG3B	170M6012
WSIQ-0580BP	580			

### 3.13 UL Coordination with Short Circuit Protection Devices

#### Standard Fault Short Circuit Current Ratings

Suitable for use on a circuit capable of delivering not more than the stated level of amperes (symmetrical rms, refer ##1 in table), 600 VAC maximum.

· **Maximum fuse rating (A) – Standard fault short circuit current**

Model	Nominal Rating (A)	3 cycle short cct rating @600 VAC ##1 †
WSIQ-0024BP	24	5 kA
WSIQ-0042BP	42	
WSIQ-0052BP	52	10 kA
WSIQ-0064BP	64	
WSIQ-0069BP	69	
WSIQ-0105BP	105	
WSIQ-0115BP	120	
WSIQ-0135BP	135	
WSIQ-0184BP	184	18 kA
WSIQ-0200BP	225	
WSIQ-0229BP	229	
WSIQ-0250BP	250	
WSIQ-0352BP	352	
WSIQ-0397BP	397	
WSIQ-0410BP	410	30 kA
WSIQ-0550BP	550	
WSIQ-0580BP	580	

† Suitable for use in a circuit with the prospective current noted, when protected by any Listed fuses or Listed circuit breakers sized according to the NEC.

### High Fault Short Circuit Current Ratings

- Maximum fuse rating (A) – High fault short circuit current

Suitable for use on a circuit capable of delivering not more than 65,000 rms symmetrical amperes, 480 VAC maximum, when protected by fuses of the stated class and rating (refer ##2 and ##3 in table).

Model	Nominal Rating (A)	Short Circuit Rating @ 480 VAC max.	Listed fuse rating (A) ##3	Fuse class ##2
WSIQ-0024BP	24	65 kA	30	Any (J, T, K-1, RK1, RK5)
WSIQ-0042BP	42		50	
WSIQ-0052BP	52		60	
WSIQ-0064BP	64		80	
WSIQ-0069BP	69		80	
WSIQ-0105BP	105		125	J, T, K-1, RK1
WSIQ-0115BP	120		125	
WSIQ-0135BP	135		150	
WSIQ-0184BP	184		200	J, T
WSIQ-0200BP	225		225	
WSIQ-0229BP	229		250	
WSIQ-0250BP	250		300	
WSIQ-0352BP	352		400	Any (J, T, K-1, RK1, RK5)
WSIQ-0397BP	397		450	
WSIQ-0410BP	410		450	
WSIQ-0550BP	550		600	
WSIQ-0580BP	580		600	

• **Circuit breakers – High fault short circuit current**

Suitable for use on a circuit capable of delivering not more than 65,000 rms symmetrical amperes, 480 VAC maximum, when protected by circuit breaker models noted in ##4, ##5 or ##6.

Model	Nominal Rating (A)	Breaker 1: Eaton (rating, A) ##4	Breaker 2: GE (rating, A) ##5	Breaker 3: LS (rating, A) <sup>1</sup> ##6
WSIQ-0024BP	24	HFD3030 (30 A)	SELA36AT0060 (60 A)	UTS150H-xxU-040 (40 A)
WSIQ-0042BP	42	HFD3050 (50 A)		UTS150H-xxU-050 (50 A)
WSIQ-0052BP	52	HFD3060 (60 A)		UTS150H-xxU-060 (60 A)
WSIQ-0064BP	64	HFD3100 (100 A)	SELA36AT0150 (150 A)	UTS150H-xxU-100 (100 A)
WSIQ-0069BP	69			UTS150H-xxU-125 (125 A)
WSIQ-0105BP	105	HFD3125 (125 A)		UTS150H-xxU-150 (150 A)
WSIQ-0115BP	120	HFD3150 (150 A)	SELA36AT0250 (250 A)	UTS150H-xxU-250 (250 A)
WSIQ-0135BP	135			UTS150H-xxU-300 (300 A)
WSIQ-0184BP	184	HFD3250 (250 A)		SELA36AT0400 (400 A)
WSIQ-0200BP	225		UTS150H-xxU-600 (600 A)	
WSIQ-0229BP	229		UTS150H-xxU-800 (800 A)	
WSIQ-0250BP	250	HFD3300 (300 A)	SELA36AT0600 (600 A)	UTS150H-xxU-800 (800 A)
WSIQ-0352BP	352	HFD3400 (400 A)		UTS150H-NG0-800
WSIQ-0397BP	397			
WSIQ-0410BP	410	HFD3600 (600 A)	SELA36AT0600 (600 A)	UTS150H-xxU-600 (600 A)
WSIQ-0550BP	550			UTS150H-xxU-800 (800 A)
WSIQ-0580BP	580			UTS150H-NG0-800

<sup>1</sup> For LS breakers, xx represents FM, FT or AT.

### 3.14 Fuse Selection for Type 2 Coordination

Type 2 coordination is achieved by using semiconductor fuses. These fuses must be able to carry motor start current and have a total clearing  $I^2t$  less than the  $I^2t$  of the soft starter SCRs.

When selecting semiconductor fuses for WSIQ, use the  $I^2t$  values in the table.

For further information on selecting semiconductor fuses, contact your local distributor or download the fuse selection application note from [www.worldwideelectric.net](http://www.worldwideelectric.net).

*I<sup>2</sup>t values for Type 2 coordination*

Model	SCR $I^2t$ (A <sup>2</sup> s)
WSIQ-0024BP	1150
WSIQ-0042BP	7200
WSIQ-0052BP	
WSIQ-0064BP	15000
WSIQ-0069BP	
WSIQ-0105BP	80000
WSIQ-0115BP	
WSIQ-0135BP	125000
WSIQ-0184BP	
WSIQ-0200BP	
WSIQ-0229BP	
WSIQ-0250BP	
WSIQ-0352BP	202000
WSIQ-0397BP	
WSIQ-0410BP	320000
WSIQ-0550BP	781000
WSIQ-0580BP	

### 3.15 Specifications

#### Supply

Mains voltage (L1, L2, L3)

WSIQ-xxxxBP ..... 200~525 VAC ( $\pm 10\%$ )

WSIQ-xxxxBP-6 ..... 380~690 VAC ( $\pm 10\%$ )

Control voltage (A1, A2, A3)

WSIQ-xxxxBP-(6) (A1, A2) ..... 110~120 VAC (+10%/-15%), 600 mA

WSIQ-xxxxBP-(6) (A2, A3) ..... 220~240 VAC (+10%/-15%), 600 mA

WSIQ-xxxxBP-(6)-24 (A1, A2) ..... 24 VAC/VDC ( $\pm 20\%$ ), 2.8 A

Mains frequency ..... 50 Hz ~ 60 Hz ( $\pm 5$  Hz)

Rated insulation voltage to earth ..... 600 VAC

Rated impulse withstand voltage ..... 6 kV

Form designation .. Bypassed or continuous, semiconductor motor starter form 1

#### Short circuit capability

Coordination with semiconductor fuses..... Type 2

Coordination with HRC fuses ..... Type 1

#### Electromagnetic capability (compliant with EU Directive 2014/35/EU)

EMC Immunity..... IEC 60947-4-2

EMC Emissions ..... IEC 60947-4-2 Class B

#### Inputs

Input rating ..... Active 24 VDC, 8 mA approx

Motor thermistor (B4, B5) ..... Trip >3.6 kW, reset <1.6 kW

#### Outputs

Relay outputs ..... 10A @ 250 VAC resistive, 5A @ 250 VAC AC15 pf 0.3

Main contactor (33, 34) ..... Normally Open

Relay output A (41, 42, 44) ..... Changeover

Relay output B (53, 54) ..... Normally Open

Analog output (21, 22)

Maximum load ..... 600 W (12 VDC @ 20 mA)

Accuracy .....  $\pm 5\%$

#### Environmental

Operating temperature ..... -10 °C to 60 °C, above 40 °C with derating

Storage temperature ..... -25 °C to + 60 °C

Operating Altitude ..... 0 - 1000 m, above 1000 m with derating

Humidity ..... 5% to 95% Relative Humidity

Pollution degree ..... Pollution Degree 3

Vibration ..... IEC 60068-2-6

Protection

WSIQ-0024BP ~ WSIQ-0135BP ..... IP20

WSIQ-0184BP ~ WSIQ-0580BP ..... IP00

**Heat dissipation**

During Start ..... 4.5 watts per ampere

During Run

WSIQ-0024BP ~ WSIQ-0052BP ..... ≤ 35 watts approx

WSIQ-0064BP ~ WSIQ-0135BP ..... ≤ 50 watts approx

WSIQ-0184BP ~ WSIQ-0250BP ..... ≤ 120 watts approx

WSIQ-0352BP ~ WSIQ-0580BP ..... ≤ 140 watts approx

**Motor Overload Protection**

Default: The default settings of parameters 1C, 1D and 1E provide Motor Overload Protection: Class 10, Trip Current 105% of FLA (full load amperage) or equivalent.

**Certification**

CE ..... EN 60947-4-2

C-UL ..... C22.2 N° 60947-4-2

UL ..... UL 60947-4-2

**Operational life (internal bypass contacts)**

..... 100 000 operations

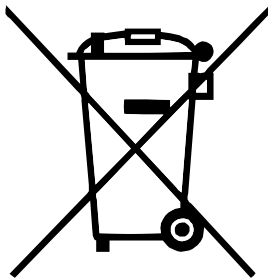
**3.16 Disposal Instructions**

Equipment containing electrical components may not be disposed of together with domestic waste.

It must be collected separately as electrical and electronic waste according to local and currently valid legislation.

## 4 Installation

**WARNING**

Do not apply mains voltage to the starter until all wiring is complete.

**WARNING**

Always apply control voltage before (or with) mains voltage.

### 4.1 Command Source

The WSIQ can be started and stopped via the digital inputs, remote keypad, communication network, smart card or scheduled auto-start/stop. The command source can be set via the Setup Tools, or using parameter 1A *Command Source*.

### 4.2 Basic Setup

#### Setup Procedure Overview

1. Mount the soft starter (refer to *Physical Installation* on page 15 for details).
2. Connect control wiring (refer to *Input Terminals* on page 26 for details).
3. Apply control voltage to the starter.
4. Configure your application:
  1. Press **MENU** to open the Menu.
  2. Press **ENTER/MENU** to open the Quick Setup menu.
  3. Scroll through the list to find your application, then press **ENTER/MENU** to begin the configuration process (refer to *Quick Setup* on page 33 for details).
5. If your application is not listed in Quick Setup:
  1. Press **EXIT/RESET** to return to the Menu.
  2. Use ▼ to scroll to Main Menu and press **ENTER/MENU**.
  3. Scroll to Motor Details and press **ENTER/MENU**, then press **ENTER/MENU** again to edit parameter 1B *Motor Full Load Current*.
  4. Set parameter 1B to match the motor's full load current (FLC).
  5. Press **ENTER/MENU** to save the setting.
6. Close the Menu by pressing **EXIT/RESET** repeatedly.
7. (Optional) Use the built-in simulation tools to check that the control wiring is connected correctly (refer to *Run simulation* on page 34).
8. Power off the soft starter.
9. Connect the motor cables to starter output terminals 2/T1, 4/T2, 6/T3.
10. Connect mains supply cables to starter input terminals 1/L1, 3/L2, 5/L3 (refer to *Power Terminations* on page 30).

The soft starter is now ready to control the motor.

### 4.3 Inputs



**CAUTION**

The control inputs are powered by the soft starter. Do not apply external voltage to the control input terminals.



**NOTE**

Cables to the control inputs must be segregated from mains voltage and motor cabling.

#### Input Terminals

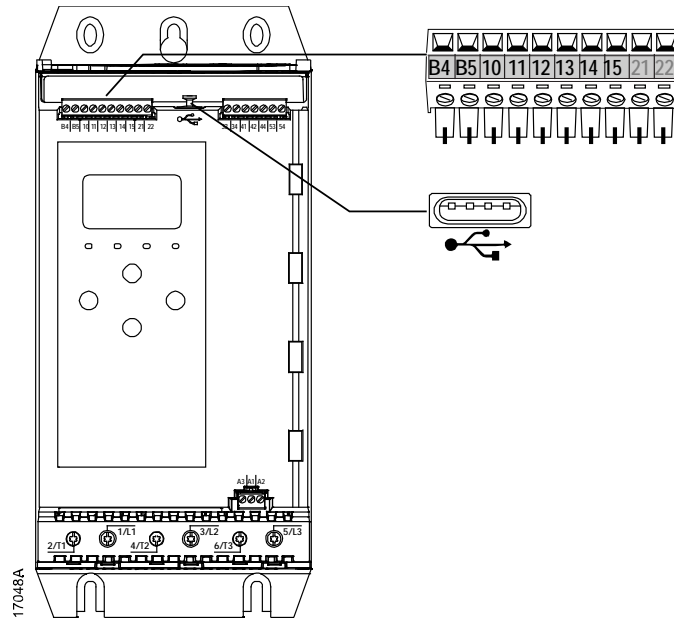

B4, B5	Motor thermistor input
10, 11	Reset input
11, 12	Start/stop input
13, 14	Programmable input A (default = Input Trip (N/O))
13, 15	Programmable input B (default = Input Trip (N/O))
	USB port

#### Motor Thermistor

Motor thermistors can be connected directly to the WSIQ. The soft starter will trip when the resistance of the thermistor circuit exceeds approximately 3.6 kW or falls below 20 W.

The thermistors must be wired in series. The thermistor circuit should be run in screened cable and must be electrically isolated from earth and all other power and control circuits.



**NOTE**

The thermistor input is disabled by default, but activates automatically when a thermistor is detected. If thermistors have previously been connected to the WSIQ but are no longer required, use the Thermistor Reset function to disable the thermistor. Thermistor Reset is accessed via the Setup Tools.

## Start/Stop

The WSIQ requires two-wire control.

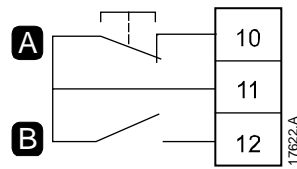

<b>A</b>	Reset
<b>B</b>	Start/Stop



### NOTE

The WSIQ will only accept commands from the control inputs if parameter 1A *Command Source* is set to Digital Input.

## Reset/Starter Disable

The reset input (10, 11) is normally closed by default. The WSIQ will not perform a start if the reset input is open. The display will show "Not Ready".

If the reset input opens while the WSIQ is running, the starter will remove power and allow the motor to coast to stop.



### NOTE

The reset input can be configured for normally closed operation. Use parameter 7I *Reset/Enable Logic*.

## Programmable Inputs

The programmable inputs (13, 14 and 13, 15) allow external equipment to control the starter.

The operation of the programmable inputs is controlled by parameters 7A ~ 7H.

## USB Port

The USB port can be used to upload a configuration file, or download parameter settings and event log information from the starter. Refer to *USB Save & Load* on page 36 for details.

## 4.4 Outputs

### Output Terminals

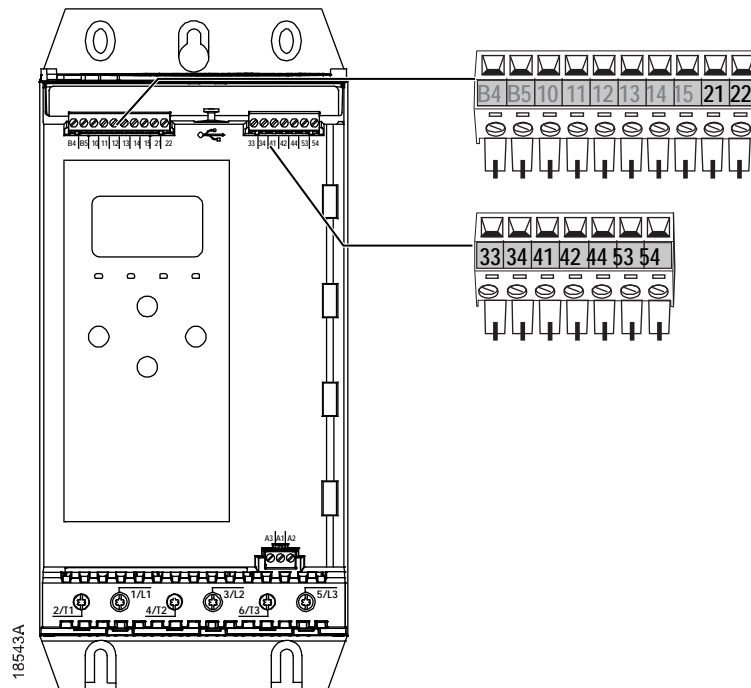

21, 22	Analog output
33, 34	Main contactor output
41, 42, 44	Relay output A (default = Run)
53, 54	Relay output B (default = Run)

#### Analog Output

The WSIQ has an analog output, which can be connected to associated equipment to monitor motor performance.

The operation of the analog output is controlled by parameters 9A ~ 9D.

#### Main Contactor Output

The main contactor output (33, 34) closes as soon as the soft starter receives a start command and remains closed while the soft starter is controlling the motor (until the motor starts a coast to stop, or until the end of a soft stop). The main contactor output will also open if the soft starter trips.



#### CAUTION

Some electronic contactor coils are not suitable for direct switching with PCB mount relays. Consult the contactor manufacturer/supplier to confirm suitability.

#### Programmable Outputs

The programmable outputs (41, 42, 44 and 53, 54) can report the status of the starter, or can be used to control associated equipment.

The operation of the programmable outputs is controlled by parameters 8A ~ 8F.

## 4.5 Control Voltage

### Control Voltage Terminals

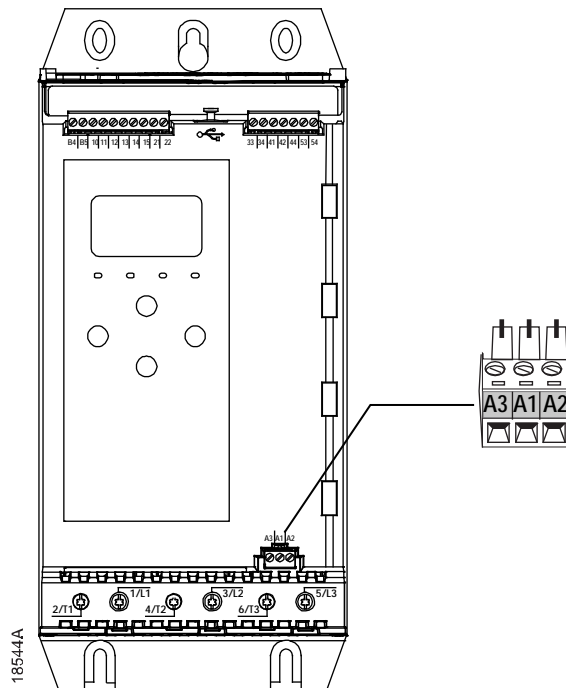

Connect the control supply according to the supply voltage being used.

- WSx-xxxxBP-(6) (110~120 VAC): A1, A2
- WSx-xxxxBP-(6) (220~240 VAC): A2, A3
- WSx-xxxxBP-(6)-24 (24 VAC/VDC): A1, A2

#### UL Compliant Installation

For models WSIQ-0184BP to WSIQ-0580BP to be UL compliant, supplementary or branch overcurrent protection must be used on the control circuit supply (A1, A2, A3), in accordance with the electrical code applicable at the installation location.

### 4.6 Power Terminations

The power input and output terminals for WSIQ are at the bottom of the unit.

- Models WSIQ-0024BP~WSIQ-0135BP use cage clamps.
- Models WSIQ-0184BP~WSIQ-0580BP use busbars.



**NOTE**

Some units use aluminium busbars. When connecting power terminations, we recommend cleaning the surface contact area thoroughly (using an emery or stainless steel brush) and using an appropriate jointing compound to prevent corrosion.

Use only copper stranded or solid conductors, rated for 75 °C or higher.

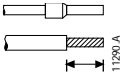
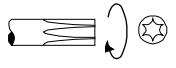
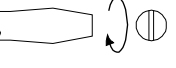
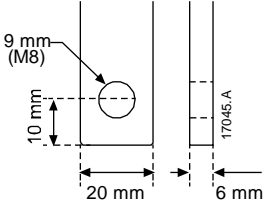
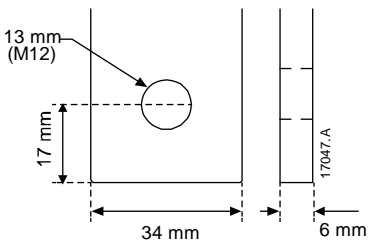
<b>WSIQ-0024BP~WSIQ-0135BP</b>	
 <p>Cable size: 6-70 mm<sup>2</sup> (AWG 10-2/0) Torque: 4 Nm (2.9 ft-lb) 14 mm (0.55 inch)</p> 	 Torx T20 x 150  Flat 7 mm x 150
<b>WSIQ-0184BP~WSIQ-0250BP</b>	<b>WSIQ-0352BP~WSIQ-0580BP</b>
<p>19 Nm (14.0 ft-lb)</p> 	<p>66 Nm (49.0 ft-lb)</p> 



**NOTE**

If the installation requires large diameter cables, it is possible to complete each termination with two smaller cables, one on each side of the busbar.

#### UL Compliant Installation

For models WSx-0184BP to WSx-0580BP to be UL compliant, you must use the recommended pressure terminal/connector.

<b>Model</b>	<b>Recommended lugs part No.</b>
WSIQ-0184BP	OPHD 185-10
WSIQ-0200BP	
WSIQ-0229BP	
WSIQ-0250BP	OPHD 150-12
WSIQ-0352BP	
WSIQ-0397BP	
WSIQ-0410BP	OPHD 240-12
WSIQ-0550BP	
WSIQ-0580BP	

### Motor Connection

WSIQ soft starters can be connected to the motor in-line or inside delta (also called three-wire and six-wire connection). When connecting in inside delta, enter the motor full load current (FLC) for parameter 1B. The WSIQ will automatically detect whether the motor is connected in-line or inside delta and will calculate the correct inside delta current level.

• **In-line installation**

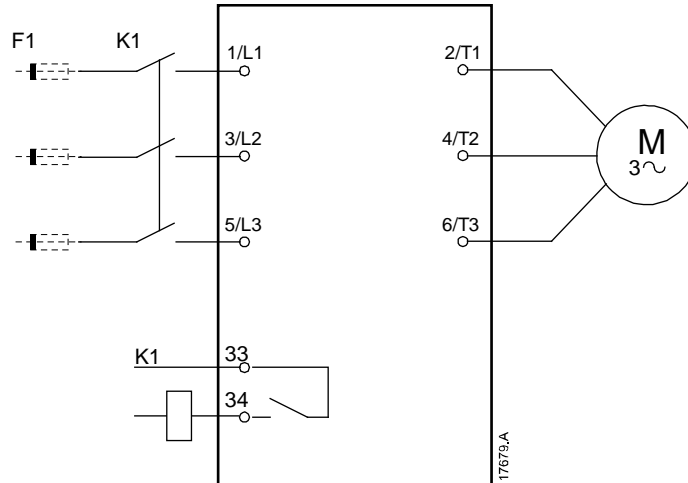

K1	Main contactor (strongly recommended)
F1	Fuses or circuit breaker (optional)
33, 34	Main contactor output

• **Inside delta installation**

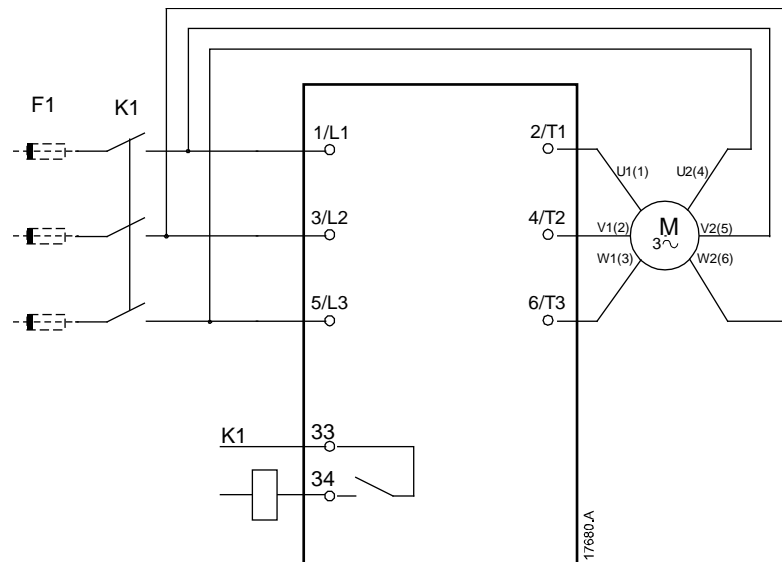

K1	Main contactor
F1	Fuses or circuit breaker (optional)
33, 34	Main contactor output

### 4.7 Typical Installation

The WSIQ is installed with a main contactor (AC3 rated). Control voltage must be supplied from the input side of the contactor.

The main contactor is controlled by the main contactor output (33, 34).

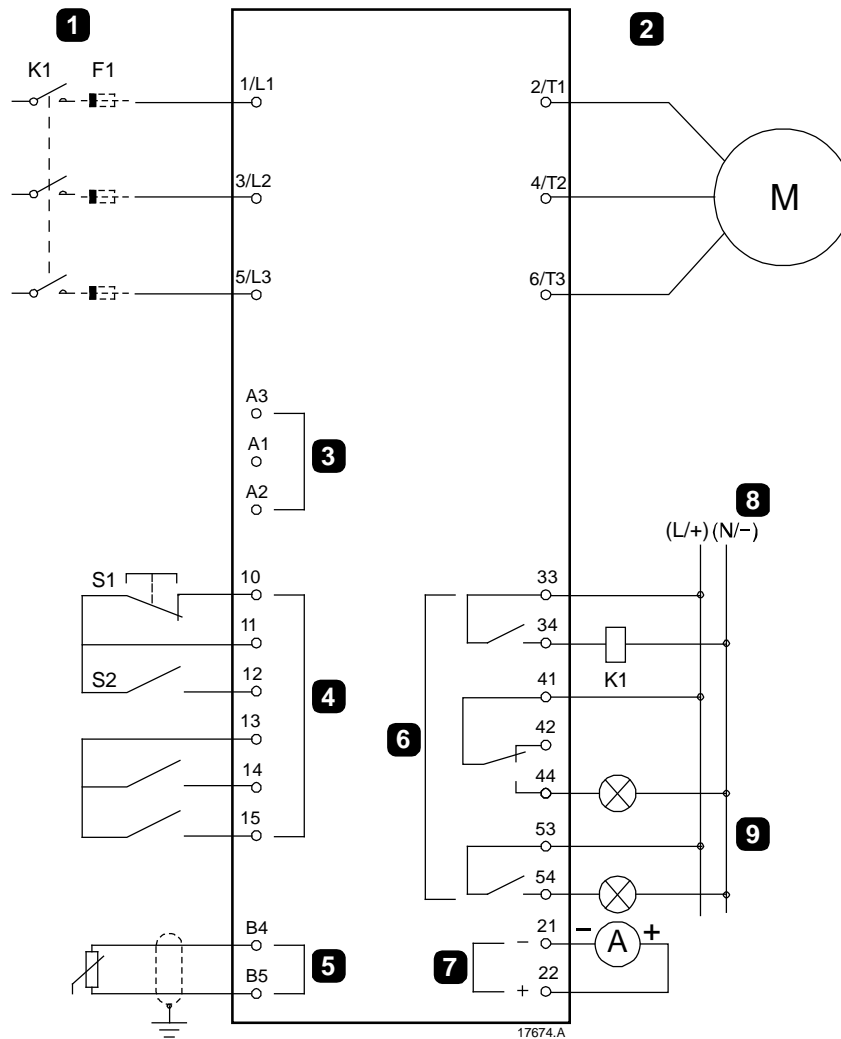

<b>1</b>	Three-phase supply
<b>2</b>	Motor
<b>3</b>	Control voltage (soft starter)
<b>4</b>	Digital inputs
<b>5</b>	Motor thermistor input
<b>6</b>	Relay outputs
<b>7</b>	Analog output
<b>8</b>	Control voltage (external equipment)
<b>9</b>	Pilot lamps

K1	Main contactor
F1	Semiconductor fuses (optional)
10, 11 (S1)	Reset
11, 12 (S2)	Start/Stop
13, 14	Programmable input A (default = Input Trip (N/O))
13, 15	Programmable input B (default = Input Trip (N/O))
B4, B5	Motor thermistor input
33, 34	Main contactor output
41, 42, 44	Relay output A (default = Run)
53, 54	Relay output B (default = Trip)
21, 22	Analog output

## 4.8 Quick Setup

The Quick Setup Menu makes it easy to configure the WSIQ for common applications. The WSIQ guides you through the most common installation parameters, and suggests a typical setting for the application. You can adjust each parameter to suit your exact requirements.

All other parameters remain at default values. To change other parameter values or review the default settings, use the menu (refer to Parameter List for details).

Always set parameter 1B *Motor Full Load Current* to match the motor's nameplate full load current.

Application	Start Mode	Start Ramp Time (seconds)	Initial Current (%)	Current Limit (%)	Adaptive Start Profile	Stop Mode	Stop Time (seconds)	Adaptive Stop Profile
Pump Centrifugal	Adaptive Control	10	200	500	Early accel.	Adaptive Control	15	Late decel.
Pump bore	Adaptive Control	3	200	500	Early accel.	Adaptive Control	3	Late decel.
Pump Hydraulic	Constant Current	2	200	350	n/a	Coast To Stop	n/a	n/a
Fan Damped	Constant Current	2	200	350	n/a	Coast To Stop	n/a	n/a
Fan Undamped	Constant Current	2	200	450	n/a	Coast To Stop	n/a	n/a
Compressor Screw	Constant Current	2	200	400	n/a	Coast To Stop	n/a	n/a
Compressor Recip	Constant Current	2	200	450	n/a	Coast To Stop	n/a	n/a
Conveyor	Constant Current	5	200	450	n/a	Coast To Stop	n/a	n/a
Bow thruster	Constant Current	5	100	400	n/a	Coast To Stop	n/a	n/a
Bandsaw	Constant Current	2	200	450	n/a	Coast To Stop	n/a	n/a



### NOTE

The Adaptive Start and Stop Profile settings only apply when using Adaptive Control. The settings are ignored for all other start and stop modes.

## 5 Setup Tools

Setup Tools includes options to load or save parameters to a backup file, set the starter's network address, check the status of the inputs and outputs, reset the thermal models or test operation using the Run Simulation.

To access the Setup Tools, press **MENU** to open the Menu then select Setup Tools.

### 5.1 Set Date and Time

To set the date and time:

1. Press **MENU** to open the menu then select Setup Tools.
2. Scroll to Set Date & Time.
3. Press the **ENTER/MENU** button to enter edit mode.
4. Press the **ENTER/MENU** and **EXIT/RESET** buttons to select which part of the date or time to edit.
5. Use the **▲** and **▼** buttons to change the value.
6. Press **ENTER/MENU** after the last digit to save the setting. When the action has been completed, the screen will briefly display a confirmation message, then return to the previous menu level.

### 5.2 Command Source

The WSIQ can be started and stopped via the digital inputs, remote keypad, communication network, smart card or scheduled auto-start/stop. The command source can be set via the Setup Tools, or using parameter 1A *Command Source*.

If the remote keypad is installed, the **LCL/RMT** button provides shortcut access to the Command Source function in Setup Tools.

### 5.3 Commissioning

Commissioning lets the starter be started and stopped via the local keypad. Use the **▲** and **▼** buttons to select a function, then press **ENTER/MENU** to send the selected command to the starter. The available functions are:

- Quick stop (coast to stop)/Reset
- Start
- Stop

### 5.4 Run simulation

The run simulation simulates a motor starting, running and stopping to confirm that the soft starter and associated equipment have been installed correctly.



#### NOTE

The soft starter must be disconnected from mains voltage.  
The simulation is only available when the soft starter is in Ready state.

To use the run simulation:

1. Press **MENU** to open the menu then select Setup Tools.
2. Scroll to Run Simulation and press **ENTER/MENU**.

Run Simulation Ready Apply Start Signal
---

3. Apply a start command from the selected command source. The WSIQ simulates its pre-start checks and closes the main contactor relay. The Run LED flashes.

Run Simulation  
Pre-Start Checks  
MENU to Continue



**NOTE**

If mains voltage is connected, an error message is shown.

Run Simulation  
ATTENTION!  
Remove Mains Volts  
MENU to Continue

4. Press **ENTER/MENU**. The WSIQ simulates starting. The Run LED flashes.

Run Simulation  
Starting X:XXs  
MENU to Continue

5. Press **ENTER/MENU**. The WSIQ simulates running.

Run Simulation  
Running  
Apply Stop Signal

6. Apply a stop command from the selected command source. The WSIQ simulates stopping. The Run LED flashes.

Run Simulation  
Stopping X:XXs  
MENU to Continue

7. Press **ENTER/MENU**. The Ready LED flashes and the main contactor relay opens.

Run Simulation  
Stopped  
MENU to Continue

8. Press **ENTER/MENU**. The WSIQ activates then deactivates each programmable output.

Run Simulation  
Prog Relay A  
On  
MENU to Continue

9. Press **ENTER/MENU** to return to the Setup Tools.

## 5.5 Load/Save Settings

Load/Save Settings allows users to:

- Reset the WSIQ's parameters to default values
- Load parameter settings from an internal file
- Save the current parameter settings to an internal file

The internal file contains default values until a user file is saved.

To load or save parameter settings:

1. Press **MENU** to open the menu then select Setup Tools.
2. Scroll to Load/Save Settings and press the **ENTER/MENU** button.
3. Scroll to the required function and press the **ENTER/MENU** button.

Load/Save Settings  
Load Defaults  
Load User Set  
Save User Set

- At the confirmation prompt, select YES to confirm or NO to cancel, then press **ENTER/MENU** to proceed.

```

Load Defaults
No
Yes

```

When the action has been completed, the screen will briefly display a confirmation message, then return to the previous menu level.

## 5.6 USB Save & Load

The USB Save & Load menu lets you:

- Save parameter settings and all event log entries to an external file (CSV format)
- Save parameter settings to an external file (proprietary format)
- Load parameter settings from a previously saved external file
- Load custom messages to display on the keypad when a programmable input is active



### NOTE

WSIQ supports FAT32 file systems. WSIQ USB functions are not compatible with NTFS file systems.

### Save & Load Procedure

- Connect the external drive to the USB port.
- Press **MENU** to open the menu then select Setup Tools.

- Scroll to USB Save & Load and press the **ENTER/MENU** button.
- Scroll to the required function and press the **ENTER/MENU** button.

```

USB Save & Load
Save Params and Logs
Save Master Params
Load Master Params

```

- At the confirmation prompt, select YES to confirm or NO to cancel, then press **ENTER/MENU** to proceed.

```

Save Params and Logs
No
Yes

```

When the action has been completed, the screen will briefly display a confirmation message, then return to the previous menu level.

### File Locations and Formats

**Save Parameters and Logs:** The WSIQ will create a directory at the top level of the USB drive, named with the soft starter's serial number. The event log and parameter settings are saved as individual CSV files, and the soft starter's software and system information are saved to a text file.

**Save Master Parameters:** The WSIQ will create a file called Master\_Parameters.par, in the top level of the USB drive.

Load Master Parameters: The WSIQ will load the file Master\_Parameters.par from the top level of the USB drive. This file can be created or edited using WORLDStart Visual management software.

Load Custom Message: The WSIQ will load the files Custom\_Message\_A.txt and Custom\_Message\_B.txt from the top level of the USB drive.

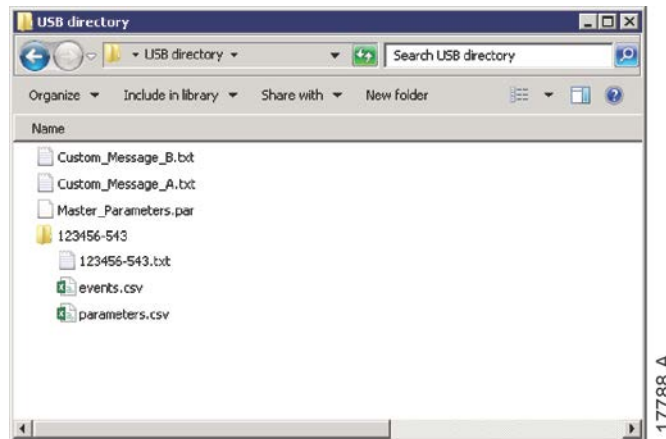

### 5.7 Auto-Start/Stop

The WSIQ can be configured to automatically start and/or stop the motor once per day. For auto-start/stop to operate:

- parameter 4A *Auto-Start/Stop Mode* must be set to 'Enable'
- parameter 1A *Command Source* must be set to 'Clock'
- the reset input must be closed
- the start input (11, 12) must be active. This allows the WSIQ to be stopped via the digital inputs in an emergency.
- parameters 4B ~ 4V: Set as required.

The Auto-Start/Stop option in Setup Tools gives quick access to the auto-start/stop parameters.

1. Press **MENU** to open the menu then select Setup Tools.

2. Scroll to Auto-Start/Stop and press the **ENTER/MENU** button.

```
Auto-Start/Stop
Start/Stop Mode
Start/Stop Sunday
Start/Stop Monday
```

3. Scroll to the required function and press the **ENTER/MENU** button.

4. Adjust the settings as required:  
 Press the **ENTER/MENU** and **EXIT/RESET** buttons to select which information to edit.  
 Use the **▲** and **▼** buttons to change the value.

```
Start/Stop Sunday
Start/Stop Disable
Start Time:      00:00
Stop Time:       00:00
```

5. To save changes, press the **ENTER/MENU** button. The WSIQ will confirm the changes.

To cancel changes, press the **EXIT/RESET** button.

### 5.8 Network Address

To use the WSIQ on an Ethernet network, separate addresses must be configured for:

- IP Address
- Gateway Address
- Subnet Mask

To set the network addresses:

1. Press **MENU** to open the menu then select Setup Tools.
2. Scroll to Network Address and press the **ENTER/MENU** button.
3. Scroll to the required function and press the **ENTER/MENU** button.
4. The first digit of the address will be highlighted.
5. Use **EXIT/RESET** and **ENTER/MENU** to select which digit to alter. Use ▲ and ▼ to change the value.
6. Press **ENTER/MENU** after the last digit to save the setting.

```
Set IP Address
192.168.000.002
```

When the action has been completed, the screen will briefly display a confirmation message, then return to the previous menu level.

**NOTE**

The network address can also be set using parameters 11H~11S.

**NOTE**

To configure the WSIQ for use with other communication protocols, use parameters 11A~11G.

### 5.9 Digital I/O State

The top line of the screen shows the start/stop, reset and programmable inputs.

The bottom line of the screen shows the fixed Main Contactor output, then programmable outputs A and B.

```
Digital I/O State
Inputs: 00000000
Outputs: 00000000
```

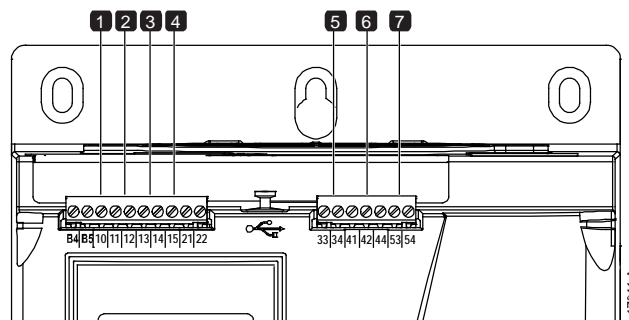

<b>1</b>	10, 11: Reset input
<b>2</b>	11, 12: Start/stop input
<b>3</b>	13, 14: Programmable input A
<b>4</b>	13, 15: Programmable input B

<b>5</b>	33, 34: Main contactor output
<b>6</b>	41, 42, 44: Relay output A
<b>7</b>	53, 54: Relay output B

## 5.10 Analog I/O State

The top line of the screen shows the state of the motor thermistor input.

The bottom line of the screen shows the value of the analog output.

Thermistor input:

- S = Short
- H = Hot
- C = Cold
- O = Open

```
Analog I/O State
Thermistor: 0
4-20mA Output: 04.0 mA
```

## 5.11 Serial Number & Rating

The top line of the screen shows the product name.

The middle line shows the unit's serial number.

The bottom line of the screen shows the model number.

```
Serial Number & Rating
WSIQ
123456-123
0069-V5-S1-C1
```

## 5.12 Software Versions

The software versions screen reports the version of each software component in the starter:

- user interface
- motor control
- remote keypad (if connected)
- parameter list
- bootloader
- expansion card (if fitted)



### NOTE

Updated software, including alternative languages, can be loaded into the starter via the USB port if required. Contact your local supplier for further information.

## 5.13 Thermistor Reset

The thermistor input is disabled by default, but activates automatically when a thermistor is detected. If thermistors have previously been connected to the WSIQ but are no longer required, use the Thermistor Reset function to disable the thermistor.

## 5.14 Reset Thermal Model

The WSIQ's advanced thermal modelling software constantly monitors the motor's performance. This allows the WSIQ to calculate the motor's temperature and ability to start successfully at any time.

The thermal model can be reset if required.



### CAUTION

Resetting the motor thermal model will compromise thermal model protection and may compromise motor life. Only reset the thermal model in an emergency.

## 6 Logs

The Logs Menu provides information on events, trips and starter performance.

To access the Logs Menu on the local keypad, press **MENU** to open the Menu then select Logs. On the remote keypad, press **LOGS**.

### 6.1 Event Log

The Event Log stores details of the starter's most recent trips, warnings, and operations (including starts, stops and configuration changes).

Event 1 is the most recent and event 384 is the oldest stored event.



#### NOTE

The event log can be exported to an external file for analysis away from the starter. Refer to *USB Save & Load* on page 36 for details.

### 6.2 Counters

The counters store statistics on the starter's operation:

- Hours run (lifetime and since counter last reset)
- Number of starts (lifetime and since counter last reset)
- Number of times the thermal model has been reset

To view the counters:

1. Open the Logs Menu.
2. Scroll to counters and press **ENTER/MENU**.
3. Use the **▲** and **▼** buttons to scroll through the counters. Press **ENTER/MENU** to view details.
4. To reset a counter, press **ENTER/MENU** then use the **▲** and **▼** buttons to select Reset/Do Not Reset. Press **ENTER** to confirm the action.

To close the counter and return to the Logs Menu, press **ENTER/MENU**.

# 7 Keypad and Feedback

## 7.1 The Keypad

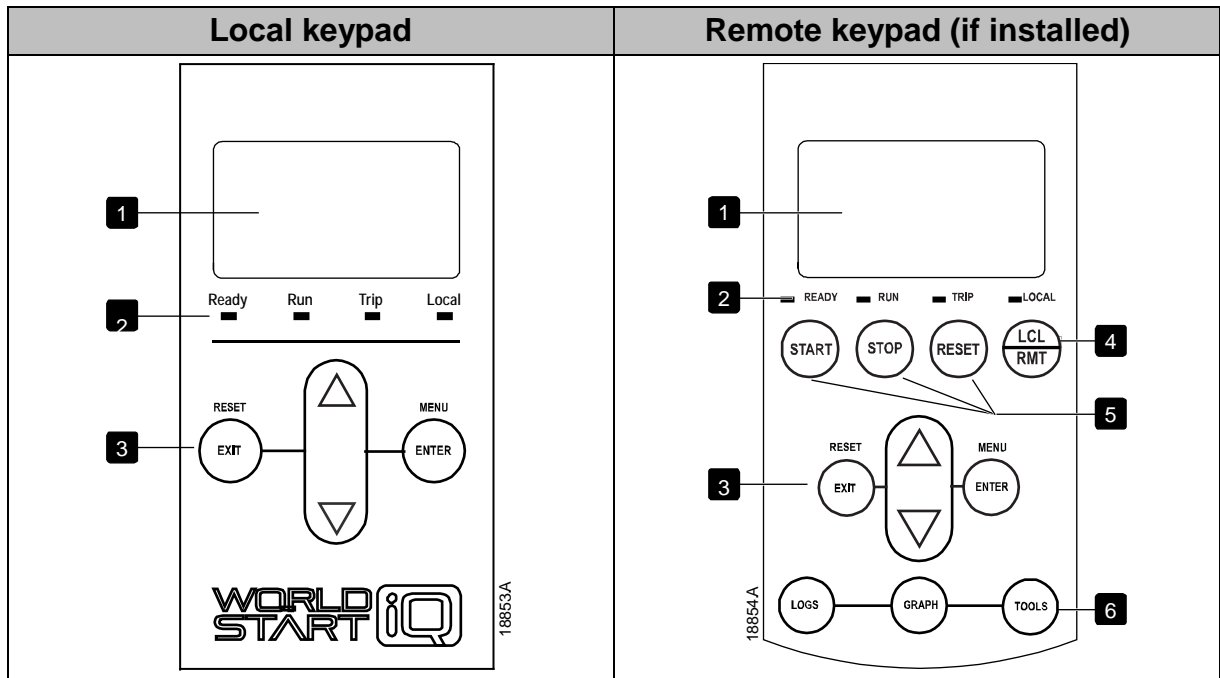

1	Four-line display for status and programming details.
2	Status LEDs.
3	Menu navigation buttons: <b>EXIT/RESET:</b> Exit the menu or parameter, or cancel a parameter change. On the local keypad, this button also resets a trip. <b>ENTER/MENU:</b> Enter a menu or parameter, or save a parameter change. <b>▲ ▼:</b> Scroll to the next or previous menu or parameter, change the setting of the current parameter or scroll through the status screens.
4	Shortcut to the command source menu in Setup Tools.
5	Soft starter local control buttons
6	Shortcut buttons for quick access to common tasks. <b>LOGS:</b> Open the Logs Menu. <b>GRAPH:</b> Select which graph to view, or pause/restart the graph (hold longer than 0.5 seconds) <b>TOOLS:</b> Open the Setup Tools.

## 7.2 Remote Keypad

The remote keypad can be used to control the soft starter if parameter 1A *Command Source* is set to 'Remote Keypad'.

- If the remote keypad is not selected as the command source, the **START**, **STOP** and **RESET** buttons will have no effect.
- The menu navigation buttons and display on the remote keypad are always active.
- If a button is pressed on the starter's local keypad, the display on the remote keypad will update to match.



### NOTE

The remote keypad can be safely connected or removed while the starter is running. It is not necessary to remove mains or control voltage.



### NOTE

If parameter 1A *Command Source* is set to Remote Keypad, removing the remote keypad will cause a trip.

## 7.3 Starter status LEDs

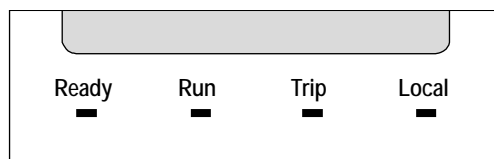

LED name	On	Flashing
Ready	The motor is stopped and the starter is ready to start.	The motor is stopped and the starter is not ready to start: <ul style="list-style-type: none"> <li>• waiting for the <i>Restart Delay</i> (parameter 5H)</li> <li>• the thermal models indicate the starter and/or motor are too hot to start safely</li> <li>• the reset input (10, 11) is open</li> </ul>
Run	The motor is in run state (receiving full voltage).	The motor is starting or stopping.
Trip	The starter has tripped.	The starter is in warning state.
Local	The starter is being controlled via a remote keypad.	–

If all LEDs are off, the starter is not receiving control voltage.

## 7.4 Displays

The keypad displays a wide range of performance information about the soft starter. To scroll through the feedback screens, press the ▲ and ▼ buttons.

### Starter information

At power-up, the starter information screen shows details of the starter's rating, software versions and serial number.

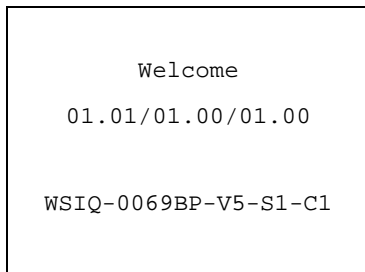

Software versions: user interface, motor control, remote keypad  
 Model code: current rating, mains voltage, frame size, control voltage  
 (remote keypad software version is only displayed when a remote keypad is connected)

**Starter Status**

The starter status screen shows details of the starter's operating status, and real-time performance information as selected in parameters 10H *User Parameter 1* and 10I *User Parameter 2*.

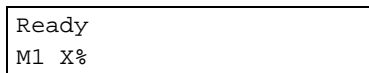

**Current**

The current screen shows real-time line current on each phase.

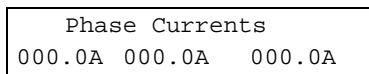

**Last Start Information**

The last start information screen shows details of the most recent successful start:

- start duration (seconds)
- maximum start current drawn (as a percentage of motor full load current)
- calculated rise in motor temperature

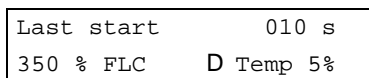

**Date and Time**

The date/time screen shows the current system date and time (24 hour format). For details on setting the date and time, refer to *Set Date and Time* on page 34.

**Performance Graph**

The performance graph provides a real-time display of operating performance. Use parameters 10B~10E to format the graph.

The display on the main keypad shows information for motor current.

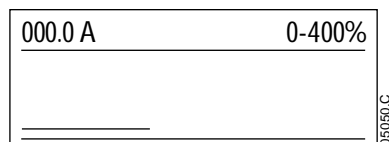

If a remote keypad is connected, press **GRAPH** to change the graph data. The graph can show:

- motor current
- motor temperature
- motor pf
- analog input data from the smart card (if installed)

## 8 Operation

### 8.1 Start, Stop and Reset Commands

The WSIQ can be started and stopped via the digital inputs, remote keypad, communication network, smart card or scheduled auto-start/stop. The command source can be set via the Setup Tools, or using parameter 1A *Command Source*.

- The WSIQ will only accept Start and Reset commands from the designated command source.
- The WSIQ will accept Stop commands from the designated command source, but can be forced to stop by opening the reset input, or by opening the start/stop input during an auto-start/stop cycle.
- The programmable input can be used to override the selected command source (refer to parameter 7A *Input A Function*).

### 8.2 Command Override

The programmable input (13, 14) can be used to override the command source, for situations where the normal control mechanism has been lost. Set parameter 7A *Input A Function* to the alternative command source (eg 'Command Override: Keypad').

While the input is active, the starter will only accept commands from the selected override source. To restore control to the command source selected in parameter 1A *Command Source*, reopen the input.

### 8.3 Scheduled Start/Stop

The WSIQ can be configured to automatically start and/or stop the motor once per day. For auto-start/stop to operate:

- parameter 4A *Auto-Start/Stop Mode* must be set to 'Enable'
- parameter 1A *Command Source* must be set to 'Clock'
- the reset input must be closed
- the start input (11, 12) must be active. This allows the WSIQ to be stopped via the digital inputs in an emergency.
- parameters 4B ~ 4V: Set as required.

### 8.4 PowerThrough

PowerThrough allows the soft starter to control the motor even if the soft starter is damaged on one phase. The WSIQ will use two phase control techniques to soft start and soft stop the motor. PowerThrough is only available with in-line installations. If the starter is installed inside delta, PowerThrough will not operate.



#### NOTE

PowerThrough operation does not support adaptive control.

- PowerThrough is only available with in-line installations. If the starter is installed inside delta, PowerThrough will not operate.
- PowerThrough remains active until '3-Phase Control Only' is reselected.

A shorted SCR or a short within the bypass contactor will trip the starter on 'Lx-Tx shorted'. If PowerThrough is enabled, the trip can be reset and subsequent starts

will use PowerThrough two-phase control; however not all features will be available. The trip LED will flash and the display will indicate '2 Phase - Damaged SCR'.

**CAUTION**

PowerThrough uses a two-phase soft start technology and additional care is required when sizing circuit breakers and protection. Contact your local supplier for assistance.

**CAUTION**

The starter will trip on Lx-Tx Shorted on the first start attempt after control power is applied. PowerThrough will not operate if control power is cycled between starts.

PowerThrough operation does not support Adaptive Control soft starting or soft stopping. In PowerThrough, the WSIQ will automatically select constant current soft starting and timed voltage ramp soft stopping. If PowerThrough is enabled, parameters 2C and 2D must be set appropriately.

## 8.5 Emergency Mode

Emergency mode allows the WSIQ to run the motor and ignore trip conditions.

Emergency mode is controlled via a programmable input (input A 13, 14 or input B 13, 15) and parameter 7A *Input A Function*/7E *Input B Function* must be set to 'Emergency Mode'. A closed circuit across 13, 14 activates emergency mode. When the WSIQ receives a start command, it will continue to run until a stop command is received, ignoring all trips and warnings.

Emergency mode can be used in conjunction with any command source.

**NOTE**

Although emergency mode operation satisfies the functionality requirements of Fire Mode, WorldWide Electric does not recommend its use in situations that require testing and/or compliance with specific standards as it is not certified.

**CAUTION**

Continued use of emergency mode is not recommended. Emergency mode may compromise the starter and/or motor life as all protections and trips are disabled.

Using the starter in emergency mode will void the product warranty.

## 8.6 Auxiliary Trip

An external trip circuit (such as a low pressure alarm switch for a pumping system) can be used to trip the soft starter and stop the motor. The external circuit is connected to a programmable input (input A 13, 14 or input B 13, 15). To control the behaviour of the trip, set the following parameters:

- Parameter 7A *Input A Function*: select 'Input Trip (N/O)'.
- Parameter 7B *Input A Trip*: set as required. For example, 'Run Only' limits the input trip to when the soft starter is running only.
- Parameter 7C *Input A Trip Delay*: sets a delay between the input activating and the soft starter tripping.

- Parameter 7D *Input A Initial Delay*: sets a delay before the soft starter monitors the state of the input, after the start signal. For example, a delay may be required to allow time for pipeline pressure to build up.
- Parameter 7J *Input A Name*: select a name, eg 'Input A Trip' (optional).

### 8.7 Typical Control Methods

The requirements of an application differ between each installation, but the methods listed below are often a good starting point for common applications.

Application	Start Mode	Start Ramp Time (seconds)	Initial Current (%FLC)	Current Limit (%FLC)	Stop Mode	Stop Time (seconds)
Bow thruster	Constant Current	5	100	400	Coast To Stop	n/a
Centrifuge (Separator)	Constant Current	1	200	450	Coast To Stop	n/a
Chipper	Constant Current	1	200	450	Coast To Stop	n/a
Compressor - reciprocating - loaded	Constant Current	1	200	450	Coast To Stop	n/a
Compressor - reciprocating - unloaded	Constant Current	1	200	400	Coast To Stop	n/a
Compressor - screw - loaded	Constant Current	1	200	400	Coast To Stop	n/a
Compressor - screw - unloaded	Constant Current	1	200	350	Coast To Stop	n/a
Conveyor - horizontal	Constant Current	5	200	400	TVR Soft Stop	10
Conveyor - inclined	Constant Current	2	200	450	Coast To Stop	n/a
Conveyor - vertical (bucket)	Constant Current	2	200	450	Coast To Stop	n/a
Crusher - cone	Constant Current	1	200	350	Coast To Stop	n/a
Crusher - jaw	Constant Current	1	200	450	Coast To Stop	n/a
Crusher - rotary	Constant Current	1	200	400	Coast To Stop	n/a
Debarker	Constant Current	1	200	350	Coast To Stop	n/a
Fan - axial (damped)	Constant Current	1	200	350	Coast To Stop	n/a
Fan - axial (undamped)	Constant Current	1	200	450	Coast To Stop	n/a
Fan - centrifugal (damped)	Constant Current	1	200	350	Coast To Stop	n/a
Fan - centrifugal (undamped)	Constant Current	1	200	450	Coast To Stop	n/a
Fan - high pressure	Constant Current	1	200	450	Coast To Stop	n/a
Mill - ball	Constant Current	1	200	450	Coast To Stop	n/a
Mill - hammer	Constant Current	1	200	450	Coast To Stop	n/a

Application	Start Mode	Start Ramp Time (seconds)	Initial Current (%FLC)	Current Limit (%FLC)	Stop Mode	Stop Time (seconds)
Pump - bore	Adaptive Control (Early accel.)	3	n/a	500	Adaptive Control (Late decel.)	3
Pump - centrifugal	Adaptive Control (Early accel.)	10	n/a	500	Adaptive Control (Late decel.)	15
Pump - Hydraulic	Constant Current	2	200	350	Coast To Stop	n/a
Pump - positive displacement	Adaptive Control (Const. accel.)	10	n/a	400	Adaptive Control (Const. decel.)	10
Pump - submersible	Adaptive Control (Early accel.)	5	n/a	500	Adaptive Control (Late decel.)	5
Saw - bandsaw	Constant Current	1	200	450	Coast To Stop	n/a
Saw - circular	Constant Current	1	200	350	Coast To Stop	n/a
Shredder	Constant Current	1	200	450	Coast To Stop	n/a

### 8.8 Soft Start Methods

#### Constant Current

Constant current is the traditional form of soft starting, which raises the current from zero to a specified level and keeps the current stable at that level until the motor has accelerated.

Constant current starting is ideal for applications where the start current must be kept below a particular level.

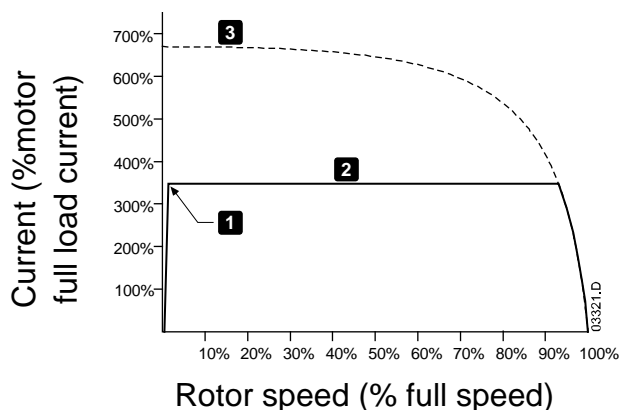

- 1: Initial Current (parameter 2C)
- 2: Current Limit (parameter 2D)
- 3: Full voltage current

#### Constant Current with Current Ramp

Current ramp soft starting raises the current from a specified starting level (1) to a maximum limit (3), over an extended period of time (2).

Current ramp starting can be useful for applications where:

- the load can vary between starts (for example a conveyor which may start loaded or unloaded). Set the initial current (parameter 2C) to a level that will start the motor with a light load, and the current limit (parameter 2D) to a level that will start the motor with a heavy load.
- the load breaks away easily, but starting time needs to be extended (for example a centrifugal pump where pipeline pressure needs to build up slowly).
- the electricity supply is limited (for example a generator set), and a slower application of load will allow greater time for the supply to respond.

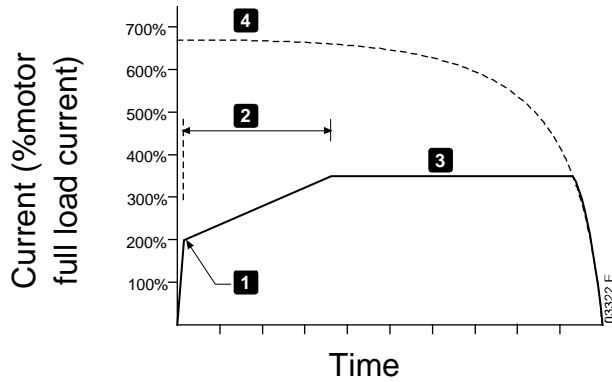

- 1: Initial Current (parameter 2C)
- 2: Start Ramp Time (parameter 2B)
- 3: Current Limit (parameter 2D)
- 4: Full voltage current

**Adaptive Control for Starting**

In an adaptive control soft start, the WSIQ adjusts the current in order to start the motor within a specified time and using a selected acceleration profile.



**NOTE**

The WSIQ will apply the current limit on all soft starts, including adaptive control. If the current limit is too low or the start ramp time (parameter 2B) is too short, the motor may not start successfully.

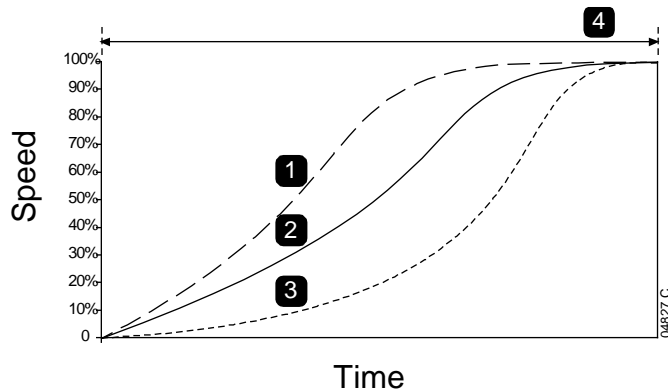

Adaptive Start Profile (parameter 2E):

- 1. Early Acceleration
- 2. Constant Acceleration
- 3. Late Acceleration
- 4. Start Ramp Time (parameter 2B)

• **Fine-tuning Adaptive Control**

If the motor does not start or stop smoothly, adjust the adaptive control gain (parameter 2L). The gain setting determines how much the WSIQ will adjust future adaptive control starts and stops, based on information from the previous start. The gain setting affects both starting and stopping performance.

- If the motor accelerates or decelerates too quickly at the end of a start or stop, increase the gain setting by 5%~10%.
- If the motor speed fluctuates during starting or stopping, decrease the gain setting slightly.



**NOTE**

The WSIQ tunes Adaptive Control to match the motor. Changing the following parameters will reset Adaptive Control and the first start/stop cycle will use constant current start/timed voltage ramp stop: 1B *Motor Full Load Current*, 2D *Current Limit*, 2L *Adaptive Control Gain*.

**Constant Current with Kickstart**

Kickstart provides a short boost of extra torque at the beginning of a start, and can be used in conjunction with current ramp or constant current starting.

Kickstart can be useful to help start loads that require high breakaway torque but then accelerate easily (for example helical rotor pumps).

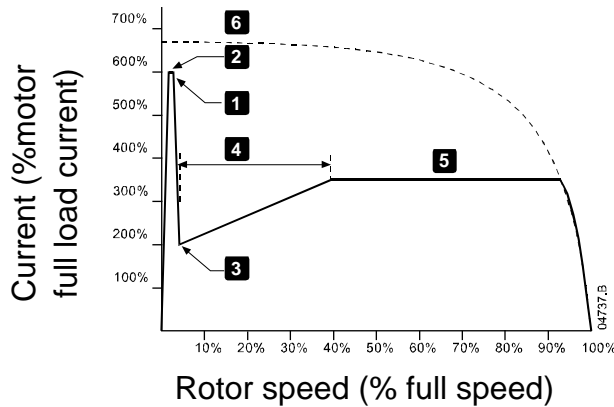

- 1: *Kickstart Level* (parameter 2G)
- 2: *Kickstart Time* (parameter 2F)
- 3: *Initial Current* (parameter 2C)
- 4: *Start Ramp Time* (parameter 2B)
- 5: *Current Limit* (parameter 2D)
- 6: Full voltage current

**8.9 Stop Methods**

**Coast to Stop**

Coast to stop lets the motor slow at its natural rate, with no control from the soft starter. The time required to stop will depend on the type of load.

**TVR Soft Stop**

Timed voltage ramp reduces the voltage to the motor gradually over a defined time. The load may continue to run after the stop ramp is complete.

Timed voltage ramp stopping can be useful for applications where the stop time needs to be extended, or to avoid transients on generator set supplies.

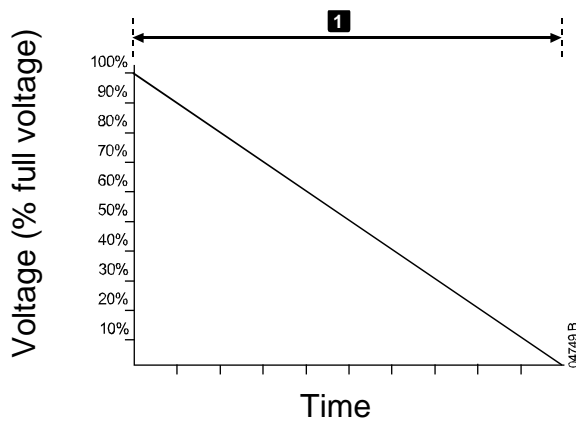

- 1: *Stop Time* (parameter 2J)

**Adaptive Control for Stopping**

In an adaptive control soft stop, the WSIQ controls the current in order to stop the motor within a specified time and using a selected deceleration profile. Adaptive Control can be useful in extending the stopping time of low inertia loads.

The first Adaptive Control stop will be a normal soft stop. This allows the WSIQ to learn the characteristics of the connected motor. This motor data is used by the WSIQ during subsequent Adaptive Control stops.

If replacing a motor connected to a WSIQ programmed for Adaptive Control starting or stopping, the starter will need to learn the characteristics of the new motor. Change the value of parameter 1B *Motor Full Load Current* or parameter 2L *Adaptive Control Gain* to initiate the re-learning process. The next start will use constant current and the next stop will use timed voltage ramp.

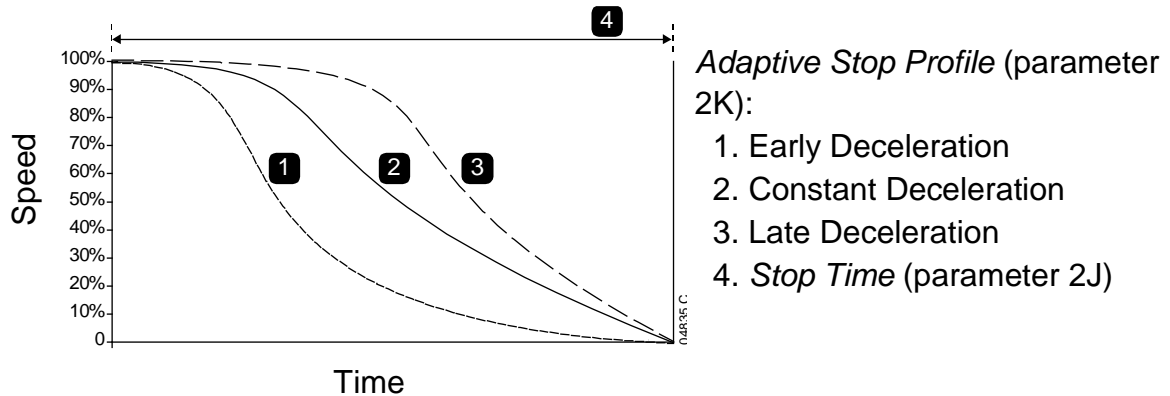

Adaptive Control is ideal for pumping applications, where it can minimise the damaging effects of fluid hammer. We recommend testing the three profiles to identify the best profile for the application.

Adaptive Stop Profile	Application
Late Deceleration	High head systems where even a small decrease in motor/pump speed results in a rapid transition between forward flow and reverse flow.
Constant Deceleration	Low to medium head, high flow applications where the fluid has high momentum.
Early Deceleration	Open pump systems where fluid must drain back through the pump without driving the pump in reverse.

**DC Brake**

Brake reduces the time required to stop the motor.

During braking an increased noise level from the motor may be audible. This is a normal part of motor braking.



**CAUTION**

When using DC brake, the mains supply must be connected to the soft starter (input terminals L1, L2, L3) in positive phase sequence.



**CAUTION**

If the brake torque is set too high, the motor will stop before the end of the brake time and the motor will suffer unnecessary heating which could result in damage. Careful configuration is required to ensure safe operation of the starter and motor.

A high brake torque setting can result in peak currents up to motor DOL being drawn while the motor is stopping. Ensure protection fuses installed in the motor branch circuit are selected appropriately.

**CAUTION**

Brake operation causes the motor to heat faster than the rate calculated by the motor thermal model. If you are using brake, install a motor thermistor or allow sufficient restart delay (parameter 5H).

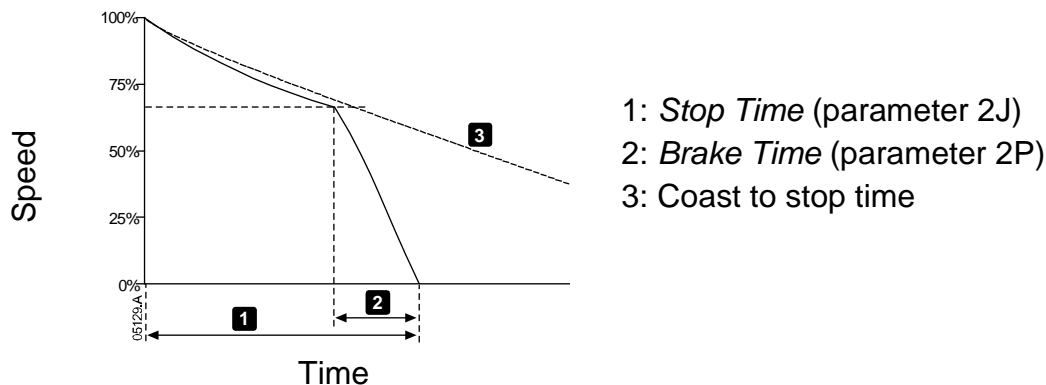

Parameter settings:

- Parameter 2I *Stop Mode*: set to 'DC Brake'.
- Parameter 2J *Stop Time*: This is the total braking time (1) and must be set sufficiently longer than the brake time (parameter 2P) to allow the pre-braking stage to reduce motor speed to approximately 70%. If the stop time is too short, braking will not be successful and the motor will coast to stop.
- Parameter 2O *DC Brake Torque*: set as required to slow the load. If set too low, the motor will not stop completely and will coast to stop after the end of the braking period.
- Parameter 2P *DC Brake Time*: Set Brake Time (parameter 2P) to approximately one quarter of the programmed Stop Time. This sets the time for the Full Brake stage (2).

**DC Brake with External Zero Speed Sensor**

For loads which may vary between braking cycles, install an external zero-speed sensor to ensure the soft starter ends DC braking when the motor has reached a standstill. This avoids unnecessary motor heating.

Configure DC brake for the longest braking time required, and also set parameter 7A *Input A Function* to 'Zero Speed Sensor'. When the motor reaches a standstill, the zero speed sensor opens the circuit across 13, 14 and the soft starter terminates the stop.

### Soft Brake

For applications with high inertia and/or a variable load requiring the maximum possible braking torque, the WSIQ can be configured for soft braking.

The WSIQ uses a changeover relay to control forward run and braking contactors. While braking, the WSIQ reverses the phase sequence to the motor and supplies reduced current, gently slowing the load.

When motor speed approaches zero, the zero speed sensor (A2) stops the soft starter and opens the braking contactor (K2).

Soft braking can be used with both the primary and secondary motor sets, and must be configured separately for each.

Parameter settings:

- Parameter 2I *Stop Mode*: set to 'Soft Brake'
- Parameter 2Q *Brake Current Limit*: set as required to slow the load
- Parameter 2R *Soft Brake Delay*: controls the time the soft starter will wait after a stop signal is received, before it begins to supply braking current to the motor. Set to allow time for K1 and K2 to switch.
- Parameter 7A *Input A Function*: set to 'Zero Speed Sensor'
- Parameter 8A *Relay A Function*: set to 'Soft Brake Relay'

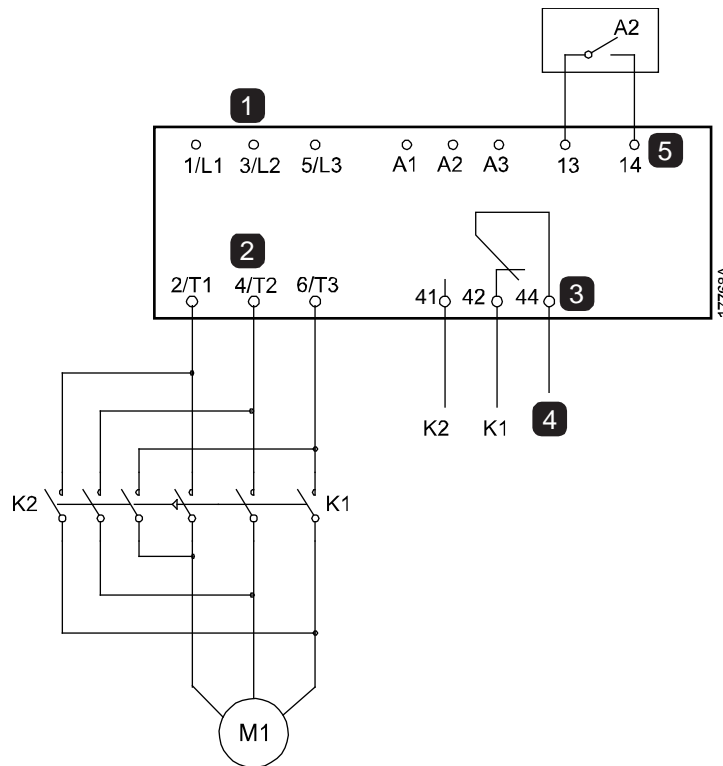

1	Three-phase supply
2	Motor terminals
3	Relay output A
4	K1/K2 coil supply
5	Programmable input A

K1	Line contactor (Run)
K2	Line contactor (Brake)
A2	Zero speed sensor

### 8.10 Jog Operation

Jog runs the motor at reduced speed, to allow alignment of the load or to assist servicing. The motor can be jogged in either forward or reverse direction.

Jog operation is controlled by the start/stop input (11, 12) and parameter 1A *Command Source* must be set to 'Digital Input'. To operate in jog, a programmable input must be set to jog (refer to parameter 7A for details) and the input must be closed when the start signal is applied.



**CAUTION**

Slow speed running is not intended for continuous operation due to reduced motor cooling.

Jog operation causes the motor to heat faster than the rate calculated by the motor thermal model. If you are using jog, install a motor thermistor or allow sufficient restart delay (parameter 5H).

The maximum available torque for jog forward is approximately 50%~75% of motor full load torque (FLT) depending on the motor. The torque when the motor is jogged in reverse is approximately 25% to 50% of FLT.

Parameters 2H and 3H *Jog Torque* control how much of the maximum available jog torque the soft starter will apply to the motor.



**NOTE**

Torque settings above 50% may cause increased shaft vibration.

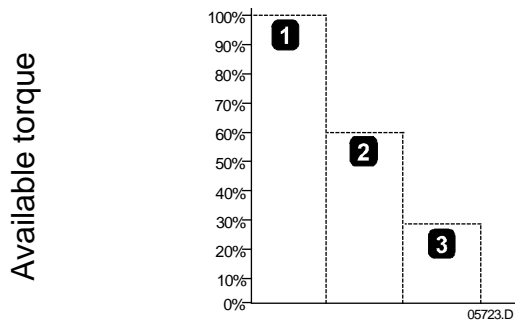

- 1. Motor FLT
- 2. Jog forward maximum torque
- 3. Jog reverse maximum torque

## 8.11 Inside Delta Operation

When connecting in inside delta, enter the motor full load current (FLC) for parameter 1B. The WSIQ will automatically detect whether the motor is connected in-line or inside delta and will calculate the correct inside delta current level.

Adaptive Control, Jog, Brake and PowerThrough functions are not supported with inside delta (six-wire) operation. If these functions are programmed when the starter is connected inside delta the behaviour is as given below:

Adaptive Control Start	The starter performs a constant current start.
Adaptive Control Stop	The starter performs a TVR soft stop if parameter 2J <i>Stop Time</i> is >0 secs. If parameter 2J is set to 0 secs the starter performs a coast to stop.
Jog	The starter issues a warning with the error message <i>Unsupported option</i> .
DC Brake	The starter performs a coast to stop.
Soft Brake	The starter performs a coast to stop.
PowerThrough	The starter trips with the error message <i>Lx-Tx Shorted</i> .



### NOTE

When connected in inside delta, the WSIQ will not detect phase loss on T2 during run.

## 8.12 Secondary Motor Set

The WSIQ can be programmed with two separate starting and stopping profiles. This allows the soft starter to control the motor in two different starting and stopping configurations.

This is ideal for situations where the motor may start in two different conditions (such as loaded and unloaded conveyors).

The WSIQ will use the secondary motor settings to control a start when instructed via a programmable input (refer to parameter 7A *Input A Function* and 7E *Input B Function*).



### NOTE

WSIQ soft starters are not suitable for controlling two separate motors. The secondary parameter set should only be used for a secondary configuration of the primary motor.

## 9 Programmable Parameters

### 9.1 Programming Menu

The Programming Menu lets you view and change programmable parameters that control how the WSIQ operates.

To open the Programming Menu, press the **MENU/ENTER** button while viewing the monitoring screens.

### 9.2 Altering Parameter Values

To change a parameter value:

- scroll to the appropriate parameter in the Programming Menu and press **ENTER/MENU** to enter edit mode.
- to alter the parameter setting, use the **▲** and **▼** buttons. Pressing **▲** or **▼** once will increase or decrease the value by one unit. If the button is held for longer than five seconds, the value will increase or decrease at a faster rate.
- to save changes, press **ENTER**. The setting shown on the display will be saved and the keypad will return to the parameter list.
- to cancel changes, press **EXIT**. The keypad will ask for confirmation, then return to the parameter list without saving changes.

### 9.3 Adjustment Lock

You can prevent users from altering parameter settings by turning on the adjustment lock (parameter 10G *Adjustment Lock*).

If a user attempts to change a parameter value when the adjustment lock is active, an error message is displayed:

Access Denied Adj Lock is On
---------------------------------

### 9.4 Parameter List

	Parameter Group	Default Setting
<b>1</b>	<b>Motor Details</b>	
1A	<i>Command Source</i>	Digital Input
1B	<i>Motor Full Load Current</i>	Model dependent
1C	<i>Locked Rotor Time</i>	00:10 (mm:ss)
1D	<i>Locked Rotor Current</i>	600%
1E	<i>Motor Service Factor</i>	105%
<b>2</b>	<b>Motor Start/Stop</b>	
2A	<i>Start Mode</i>	Constant Current
2B	<i>Start Ramp Time</i>	00:10 (mm:ss)
2C	<i>Initial Current</i>	200%
2D	<i>Current Limit</i>	350%
2E	<i>Adaptive Start Profile</i>	Constant Acceleration
2F	<i>Kickstart Time</i>	000 ms
2G	<i>Kickstart Level</i>	500%
2H	<i>Jog Torque</i>	50%

2I	<i>Stop Mode</i>	TVR Soft Stop
2J	<i>Stop Time</i>	00:01 (mm:ss)
2K	<i>Adaptive Stop Profile</i>	Constant Deceleration
2L	<i>Adaptive Control Gain</i>	75%
2M	<i>Multi Pump</i>	Single Pump
2N	<i>Start Delay</i>	00:00 (mm:ss)
2O	<i>DC Brake Torque</i>	20%
2P	<i>DC Brake Time</i>	00:01 (mm:ss)
2Q	<i>Brake Current Limit</i>	250%
2R	<i>Soft Brake Delay</i>	400 ms

**3 Motor Start/Stop 2**

3A	<i>Start Mode-2</i>	Constant Current
3B	<i>Start Ramp Time-2</i>	00:10 (mm:ss)
3C	<i>Initial Current-2</i>	200%
3D	<i>Current Limit-2</i>	350%
3E	<i>Adaptive Start Profile-2</i>	Constant Acceleration
3F	<i>Kickstart Time-2</i>	000 ms
3G	<i>Kickstart Level-2</i>	500%
3H	<i>Jog Torque-2</i>	50%
3I	<i>Stop Mode-2</i>	TVR Soft Stop
3J	<i>Stop Time-2</i>	00:01 (mm:ss)
3K	<i>Adaptive Stop Profile-2</i>	Constant Deceleration
3L	<i>Adaptive Control Gain-2</i>	75%
3M	<i>Multi Pump-2</i>	Single Pump
3N	<i>Start Delay-2</i>	00:00 (mm:ss)
3O	<i>DC Brake Torque-2</i>	20%
3P	<i>DC Brake Time-2</i>	00:01 (mm:ss)
3Q	<i>Brake Current Limit-2</i>	250%
3R	<i>Soft Brake Delay-2</i>	400 ms

**4 Auto-Start/Stop**

4A	<i>Auto-Start/Stop Mode</i>	Disable
4B	<i>Sunday Mode</i>	Start/Stop Disable
4C	<i>Sunday Start Time</i>	00:00 (hh:mm)
4D	<i>Sunday Stop Time</i>	00:00 (hh:mm)
4E	<i>Monday Mode</i>	Start/Stop Disable
4F	<i>Monday Start Time</i>	00:00 (hh:mm)
4G	<i>Monday Stop Time</i>	00:00 (hh:mm)
4H	<i>Tuesday Mode</i>	Start/Stop Disable
4I	<i>Tuesday Start Time</i>	00:00 (hh:mm)
4J	<i>Tuesday Stop Time</i>	00:00 (hh:mm)
4K	<i>Wednesday Mode</i>	Start/Stop Disable

4L	<i>Wednesday Start Time</i>	00:00 (hh:mm)
4M	<i>Wednesday Stop Time</i>	00:00 (hh:mm)
4N	<i>Thursday Mode</i>	Start/Stop Disable
4O	<i>Thursday Start Time</i>	00:00 (hh:mm)
4P	<i>Thursday Stop Time</i>	00:00 (hh:mm)
4Q	<i>Friday Mode</i>	Start/Stop Disable
4R	<i>Friday Start Time</i>	00:00 (hh:mm)
4S	<i>Friday Stop Time</i>	00:00 (hh:mm)
4T	<i>Saturday Mode</i>	Start/Stop Disable
4U	<i>Saturday Start Time</i>	00:00 (hh:mm)
4V	<i>Saturday Stop Time</i>	00:00 (hh:mm)

## 5 Protection Levels

5A	<i>Current Imbalance</i>	30%
5B	<i>Current Imbalance Delay</i>	00:03 (mm:ss)
5C	<i>Undercurrent</i>	20%
5D	<i>Undercurrent Delay</i>	00:05 (mm:ss)
5E	<i>Overcurrent</i>	400%
5F	<i>Overcurrent Delay</i>	00:00 (mm:ss)
5G	<i>Excess Start Time</i>	00:20 (mm:ss)
5H	<i>Restart Delay</i>	00:10 (mm:ss)

## 6 Protection Actions

6A	<i>Current Imbalance</i>	Soft Trip and Log
6B	<i>Undercurrent</i>	Soft Trip and Log
6C	<i>Overcurrent</i>	Soft Trip and Log
6D	<i>Excess Start Time</i>	Soft Trip and Log
6E	<i>Input A Trip</i>	Soft Trip and Log
6F	<i>Input B Trip</i>	Soft Trip and Log
6G	<i>Network Communications</i>	Soft Trip and Log
6H	<i>Remote Keypad Fault</i>	Soft Trip and Log
6I	<i>Frequency</i>	Soft Trip and Log
6J	<i>Motor Overtemperature</i>	Soft Trip and Log
6K	<i>Motor Thermistor Circuit</i>	Soft Trip and Log
6L	<i>Shorted SCR Action</i>	3-Phase Control Only
6M	<i>Battery/Clock</i>	Soft Trip and Log
6N	<i>Pressure Sensor</i>	Soft Trip and Log
6O	<i>Flow Sensor</i>	Soft Trip and Log
6P	<i>Depth Sensor</i>	Soft Trip and Log
6Q	<i>High Pressure</i>	Soft Trip and Log
6R	<i>Low Pressure</i>	Soft Trip and Log
6S	<i>High Flow</i>	Soft Trip and Log
6T	<i>Low Flow</i>	Soft Trip and Log

6U	<i>Flow Switch</i>	Soft Trip and Log
6V	<i>Well Depth</i>	Soft Trip and Log
6W	<i>RTD/PT100 B</i>	Soft Trip and Log

**7 Inputs**

7A	<i>Input A Function</i>	Input Trip (N/O)
7B	<i>Input A Trip</i>	Operating Only
7C	<i>Input A Trip Delay</i>	00:00 (mm:ss)
7D	<i>Input A Initial Delay</i>	00:00 (mm:ss)
7E	<i>Input B Function</i>	Input Trip (N/O)
7F	<i>Input B Trip</i>	Operating Only
7G	<i>Input B Trip Delay</i>	00:00 (mm:ss)
7H	<i>Input B Initial Delay</i>	00:00 (mm:ss)
7I	<i>Reset/Enable Logic</i>	Normally Closed (N/C)
7J	<i>Input A Name</i>	Input A Trip
7K	<i>Input B Name</i>	Input B Trip

**8 Relay Outputs**

8A	<i>Relay A Function</i>	Run
8B	<i>Relay A On Delay</i>	00:00 (mm:ss)
8C	<i>Relay A Off Delay</i>	00:00 (mm:ss)
8D	<i>Relay B Function</i>	Run
8E	<i>Relay B On Delay</i>	00:00 (mm:ss)
8F	<i>Relay B Off Delay</i>	00:00 (mm:ss)
8G	<i>Low Current Flag</i>	50%
8H	<i>High Current Flag</i>	100%
8I	<i>Motor Temperature Flag</i>	80%
8J	<i>Main Contactor Time</i>	400 ms

**9 Analog Output**

9A	<i>Analog Output A</i>	Current (% FLC)
9B	<i>Analog A Scale</i>	4-20 mA
9C	<i>Analog A Maximum Adjustment</i>	100%
9D	<i>Analog A Minimum Adjustment</i>	000%

**10 Display**

10A	<i>Language</i>	English
10B	<i>Temperature Scale</i>	Celsius
10C	<i>Graph Timebase</i>	30 seconds
10D	<i>Graph Maximum Adjustment</i>	400%
10E	<i>Graph Minimum Adjustment</i>	0%
10F	<i>Current Calibration</i>	100%
10G	<i>Adjustment Lock</i>	Read & Write
10H	<i>User Parameter 1</i>	Blank
10I	<i>User Parameter 2</i>	Blank

<b>11 Communications Card</b>		
11A	<i>Modbus Address</i>	1
11B	<i>Modbus Baud Rate</i>	9600
11C	<i>Modbus Parity</i>	None
11D	<i>Modbus Timeout</i>	Off
11E	<i>Devicenet Address</i>	0
11F	<i>Devicenet Baud Rate</i>	125kB
11G	<i>Profibus Address</i>	1
11H	<i>Gateway Address</i>	192
11I	<i>Gateway Address 2</i>	168
11J	<i>Gateway Address 3</i>	0
11K	<i>Gateway Address 4</i>	100
11L	<i>IP Address</i>	192
11M	<i>IP Address 2</i>	168
11N	<i>IP Address 3</i>	0
11O	<i>IP Address 4</i>	2
11P	<i>Subnet Mask</i>	255
11Q	<i>Subnet Mask 2</i>	255
11R	<i>Subnet Mask 3</i>	255
11S	<i>Subnet Mask 4</i>	0
11T	<i>DHCP</i>	Disable
11U	<i>Location ID</i>	0
<b>12 Pump Input Configuration</b>		
12A	<i>Auto-Reset Count</i>	0
12B	<i>Auto-Reset Delay</i>	00:05 (mm:ss)
12C	<i>Pressure Sensor Type</i>	None
12D	<i>Pressure Units</i>	kPa
12E	<i>Pressure at 4 mA</i>	0
12F	<i>Pressure at 20 mA</i>	0
12G	<i>Flow Sensor Type</i>	None
12H	<i>Flow Units</i>	litres/second
12I	<i>Flow at 4 mA</i>	0
12J	<i>Flow at 20 mA</i>	0
12K	<i>Units per Minute at Max Flow</i>	0
12L	<i>Pulses per Minute at Max Flow</i>	0
12M	<i>Units per Pulse</i>	0
12N	<i>Depth Sensor Type</i>	None
12O	<i>Depth Units</i>	metres
12P	<i>Depth at 4 mA</i>	0
12Q	<i>Depth at 20 mA</i>	0

<b>13</b>	<b>Flow Protection</b>	
13A	<i>High Flow Trip Level</i>	10
13B	<i>Low Flow Trip Level</i>	5
13C	<i>Flow Start Delay</i>	00:00:50 (mm:ss:ms)
13D	<i>Flow Response Delay</i>	00:00:50 (mm:ss:ms)
<b>14</b>	<b>Pressure Protection</b>	
14A	<i>High Pressure Trip Level</i>	10
14B	<i>High Pressure Start Delay</i>	00:00:50 (mm:ss:ms)
14C	<i>High Pressure Response Delay</i>	00:00:50 (mm:ss:ms)
14D	<i>Low Pressure Trip Level</i>	5
14E	<i>Low Pressure Start Delay</i>	00:00:50 (mm:ss:ms)
14F	<i>Low Pressure Response Delay</i>	00:00:50 (mm:ss:ms)
<b>15</b>	<b>Pressure Control</b>	
15A	<i>Pressure Control Mode</i>	Off
15B	<i>Start Pressure Level</i>	5
15C	<i>Start Response Delay</i>	00:00:50 (mm:ss:ms)
15D	<i>Stop Pressure Level</i>	10
15E	<i>Stop Response Delay</i>	00:00:50 (mm:ss:ms)
<b>16</b>	<b>Depth Protection</b>	
16A	<i>Depth Trip Level</i>	5
16B	<i>Depth Reset Level</i>	10
16C	<i>Depth Start Delay</i>	00:00:50 (mm:ss:ms)
16D	<i>Depth Response Delay</i>	00:00:50 (mm:ss:ms)
<b>17</b>	<b>Thermal Protection</b>	
17A	<i>Temperature Sensor Type</i>	None
17B	<i>Temperature Trip Level</i>	40
<b>20</b>	<b>Advanced</b>	
20A	<i>Tracking Gain</i>	50%
20B	<i>Pedestal Detect</i>	80%
20C	<i>Bypass Contactor Delay</i>	150 ms
20D	<i>Model Rating</i>	0020
20E	<i>Screen Timeout</i>	1 minute

## 9.5 1 Motor Details

### 1A – Command Source

<b>Options:</b>	Digital Input (default)	The WSIQ will accept start and stop commands from the digital inputs.
	Network	The WSIQ will accept start and stop commands from the communication expansion card.
	Remote Keypad	The WSIQ will accept start and stop commands from the Remote Keypad.
	Clock	The WSIQ will start and stop as scheduled in parameters 4A to 4V.
	Smart Card	The WSIQ will accept start and stop commands from the smart card.
	Smart Card + Clock	The WSIQ will accept start commands from the smart card if they are within the operating schedule set in parameters 4A to 4V. A stop command from the smart card will be accepted regardless of the schedule.

**Description:** Selects the command source for controlling the soft starter.

### 1B – Motor Full Load Current

**Range:** Model dependent

**Description:** Matches the starter to the connected motor's full load current. Set to the full load current (FLC) rating shown on the motor nameplate.

### 1C – Locked Rotor Time

**Range:** 0:01 - 2:00 (minutes:seconds)      **Default:** 10 seconds

**Description:** Sets the maximum length of time the motor can sustain locked rotor current from cold before reaching its maximum temperature. Set according to the motor datasheet.

### 1D – Locked Rotor Current

**Range:** 400% - 1200% FLC      **Default:** 600%

**Description:** Sets the locked rotor current of the connected motor, as a percentage of full load current. Set according to the motor datasheet.

### 1E – Motor Service Factor

**Range:** 100% - 130%      **Default:** 105%

**Description:** Sets the motor service factor used by the thermal model. If the motor runs at full load current, it will reach 100%. Set according to the motor datasheet.



#### NOTE

Parameters 1C, 1D and 1E determine the trip current for motor overload protection. The default settings of parameters 1C, 1D and 1E provide Motor Overload Protection: Class 10, Trip Current 105% of FLA (full load amperage) or equivalent.

## 9.6 2 Motor Start/Stop

### 2A – Start Mode

---

**Options:** Constant Current (default)  
Adaptive Control

**Description:** Selects the soft start mode.



**NOTE**

The WSIQ will apply the current limit on all soft starts, including adaptive control. If the current limit is too low or the start ramp time (parameter 2B) is too short, the motor may not start successfully.

### 2B – Start Ramp Time

---

**Range:** 0:01 - 3:00 (minutes:seconds)      **Default:** 10 seconds

**Description:** Sets the total start time for an Adaptive Control start or the ramp time for current ramp starting (from the initial current to the current limit).

### 2C – Initial Current

---

**Range:** 100% - 600% FLC      **Default:** 200%

**Description:** Sets the initial start current level for current ramp starting, as a percentage of motor full load current. Set so that the motor begins to accelerate immediately after a start is initiated.  
If current ramp starting is not required, set the initial current equal to the current limit.

### 2D – Current Limit

---

**Range:** 100% - 600% FLC      **Default:** 350%

**Description:** Sets the current limit for constant current and current ramp soft starting, as a percentage of motor full load current.

### 2E – Adaptive Start Profile

---

**Options:** Early Acceleration  
Constant Acceleration (default)  
Late Acceleration

**Description:** Selects which profile the WSIQ will use for an Adaptive Control soft start.



**NOTE**

The WSIQ will apply the current limit on all soft starts, including adaptive control. If the current limit is too low or the start ramp time (parameter 2B) is too short, the motor may not start successfully.

### 2F – Kickstart Time

---

**Range:** 0 – 2000 milliseconds      **Default:** 0000 milliseconds

**Description:** Sets the kickstart duration. A setting of 0 disables kickstart.

**2G – Kickstart Level**

---

**Range:** 100% - 700% FLC **Default:** 500%**Description:** Sets the level of the kickstart current.**CAUTION**

Kickstart subjects the mechanical equipment to increased torque levels. Ensure the motor, load and couplings can handle the additional torque before using this feature.

**2H – Jog Torque**

---

The WSIQ can jog the motor at a reduced speed, which allows precise positioning of belts and flywheels. Jog can be used for either forward or reverse operation.

**Range:** 20% - 100% **Default:** 50%**Description:** Sets the current limit for jog operation.**2I – Stop Mode**

---

**Options:** Coast To Stop  
TVR Soft Stop (default)  
Adaptive Control  
DC Brake  
Soft Brake**Description:** Selects the stop mode.**2J – Stop Time**

---

**Range:** 0:00 - 4:00 (minutes:seconds) **Default:** 1 second**Description:** Sets the time for soft stopping the motor using timed voltage ramp or Adaptive Control.

If a main contactor is installed, the contactor must remain closed until the end of the stop time. Use the main contactor output (33, 34) to control the main contactor.

**2K – Adaptive Stop Profile**

---

**Options:** Early Deceleration  
Constant Deceleration (default)  
Late Deceleration**Description:** Selects which profile the WSIQ will use for an Adaptive Control soft stop.**2L – Adaptive Control Gain**

---

**Range:** 1% - 200% **Default:** 75%**Description:** Adjusts the performance of Adaptive Control. This setting affects both starting and stopping control.

**2M – Multi Pump**

---

**Options:** Single Pump (default)  
Manifold Pump

**Description:** Adjusts the performance of adaptive control to suit installations with multiple pumps connected to a common outlet manifold.

**2N – Start Delay**

---

**Range:** 0:00 - 3:20 (minutes:seconds)      **Default:** 0 second

**Description:** Sets a delay after the starter receives a start command, before it starts the motor.

**2O – DC Brake Torque**

---

**Range:** 20% - 100%      **Default:** 20%

**Description:** Sets the amount of brake torque the WSIQ will use to slow the motor.

**2P – DC Brake Time**

---

**Range:** 0:01 - 0:30 (minutes:seconds)      **Default:** 1 second

**Description:** Sets the duration for DC injection during a braking stop.

**2Q – Brake Current Limit**

---

**Range:** 100% - 600% FLC      **Default:** 250%

**Description:** Sets the current limit for soft brake.

**2R – Soft Brake Delay**

---

**Range:** 400 - 2000 milliseconds      **Default:** 400 milliseconds

**Description:** Sets the time the soft starter will wait after a stop signal is received, before it begins to supply braking current to the motor. Set to allow time for K1 and K2 to switch.

**9.7 3 Motor Start/Stop-2**

The parameters in this group control the operation of the secondary configuration of the motor. Use the programmable input to select the active motor set.

To use the secondary motor data, parameter 7A must be set to 'Motor Set Select' and the input must be closed when a start command is given. The WSIQ checks which motor data to use at a start, and will use that motor data for the entire start/stop cycle.

**NOTE**

WSIQ soft starters are not suitable for controlling two separate motors. The secondary parameter set should only be used for a secondary configuration of the primary motor.

**3A – Start Mode-2**

---

**Options:** Constant Current (default)  
Adaptive Control

**Description:** Selects the soft start mode.

**3B – Start Ramp Time-2**

**Range:** 0:01 - 3:00 (minutes:seconds)      **Default:** 10 seconds

**Description:** Sets the total start time for an Adaptive Control start or the ramp time for current ramp starting (from the initial current to the current limit).

**3C – Initial Current-2**

**Range:** 100% - 600% FLC      **Default:** 200%

**Description:** Sets the initial start current level for current ramp starting, as a percentage of motor full load current. Set so that the motor begins to accelerate immediately after a start is initiated.  
If current ramp starting is not required, set the initial current equal to the current limit.

**3D – Current Limit-2**

**Range:** 100% - 600% FLC      **Default:** 350%

**Description:** Sets the current limit for constant current and current ramp soft starting, as a percentage of motor full load current.

**NOTE**

The WSIQ will apply the current limit on all soft starts, including adaptive control. If the current limit is too low or the start ramp time (parameter 2B) is too short, the motor may not start successfully.

**3E – Adaptive Start Profile-2**

**Options:** Early Acceleration  
Constant Acceleration (default)  
Late Acceleration

**Description:** Selects which profile the WSIQ will use for an Adaptive Control soft start.

**3F – Kickstart Time-2**

**Range:** 0 – 2000 milliseconds      **Default:** 0000 milliseconds

**Description:** Sets the kickstart duration. A setting of 0 disables kickstart.

**3G – Kickstart Level-2**

**Range:** 100% - 700% FLC      **Default:** 500%

**Description:** Sets the level of the kickstart current.

**3H – Jog Torque-2**

**Range:** 20% - 100%      **Default:** 50%

**Description:** Sets the current limit for jog operation.

---

**3I – Stop Mode-2**

---

**Options:** Coast To Stop  
TVR Soft Stop (default)  
Adaptive Control  
DC Brake  
Soft Brake

**Description:** Selects the stop mode.

---

**3J – Stop Time-2**

---

**Range:** 0:00 - 4:00 (minutes:seconds)      **Default:** 1 second

**Description:** Sets the time for soft stopping the motor using timed voltage ramp or Adaptive Control.  
If a main contactor is installed, the contactor must remain closed until the end of the stop time. Use the main contactor output (33, 34) to control the main contactor.

---

**3K – Adaptive Stop Profile-2**

---

**Options:** Early Deceleration  
Constant Deceleration (default)  
Late Deceleration

**Description:** Selects which profile the WSIQ will use for an Adaptive Control soft stop.

---

**3L – Adaptive Control Gain-2**

---

**Range:** 1%~200%      **Default:** 75%

**Description:** Adjusts the performance of Adaptive Control. This setting affects both starting and stopping control.

---

**3M – Multi Pump-2**

---

**Options:** Single Pump (default)  
Manifold Pump

**Description:** Adjusts the performance of adaptive control to suit installations with multiple pumps connected to a common outlet manifold.

---

**3N – Start Delay-2**

---

**Range:** 0:00 - 3:20 (minutes:seconds)      **Default:** 0 second

**Description:** Sets a delay after the starter receives a start command, before it starts the motor.

---

**3O – DC Brake Torque-2**

---

**Range:** 20% - 100%      **Default:** 20%

**Description:** Sets the amount of brake torque the WSIQ will use to slow the motor.

**3P – DC Brake Time-2**

---

**Range:** 0:01 - 0:30 (minutes:seconds)      **Default:** 1second

**Description:** Sets the duration for DC injection during a braking stop.

**3Q – Brake Current Limit-2**

---

**Range:** 100% - 600% FLC      **Default:** 250%

**Description:** Sets the current limit for soft brake.

**3R – Soft Brake Delay-2**

---

**Range:** 400 - 2000 milliseconds      **Default:** 400 milliseconds

**Description:** Sets the time the soft starter will wait after a stop signal is received, before it begins to supply braking current to the motor. Set to allow time for K1 and K2 to switch.

**9.8 4 Auto-Start/Stop**

The WSIQ can be configured to automatically start and/or stop the motor once per day. For auto-start/stop to operate:

- parameter 4A *Auto-Start/Stop Mode* must be set to 'Enable'
- parameter 1A *Command Source* must be set to 'Clock'
- the reset input must be closed
- the start input (11, 12) must be active. This allows the WSIQ to be stopped via the digital inputs in an emergency.
- parameters 4B ~ 4V: Set as required.

**4A – Auto-Start/Stop Mode**

---

**Options:** Disable (default)  
Enable

**Description:** Enable or disable auto-start/stop operation.

**4B – Sunday Mode**

---

<b>Options:</b>	Start/Stop Disable (default)	Disables auto-start/stop control. Any times scheduled in parameters 4C or 4D will be ignored.
	Start Only Enable	Enables auto-start control. Any auto-stop times scheduled in parameter 4D will be ignored.
	Stop Only Enable	Enables auto-stop control. Any auto-start times scheduled in parameter 4C will be ignored.
	Start/Stop Enable	Enables auto-start and auto-stop control.

**Description:** Enables or disables auto-start/stop for Sunday.

**4C – Sunday Start Time**

---

**Range:** 00:00 - 23:59      **Default:** 00:00

**Description:** Sets the auto-start time for Sunday (24 hour format).



**4N – Thursday Mode**

<b>Options:</b>	Start/Stop Disable (default)	Stop Only Enable
	Start Only Enable	Start/Stop Enable

**Description:** Enables or disables auto-start/stop for Thursday.

**4O – Thursday Start Time**

<b>Range:</b>	00:00 - 23:59	<b>Default:</b>	00:00
---------------	---------------	-----------------	-------

**Description:** Sets the auto-start time for Thursday (24 hour format).

**4P – Thursday Stop Time**

<b>Range:</b>	00:00 - 23:59	<b>Default:</b>	00:00
---------------	---------------	-----------------	-------

**Description:** Sets the auto-stop time for Thursday (24 hour format).

**4Q – Friday Mode**

<b>Options:</b>	Start/Stop Disable (default)	Stop Only Enable
	Start Only Enable	Start/Stop Enable

**Description:** Enables or disables auto-start/stop for Friday.

**4R – Friday Start Time**

<b>Range:</b>	00:00 - 23:59	<b>Default:</b>	00:00
---------------	---------------	-----------------	-------

**Description:** Sets the auto-start time for Friday (24 hour format).

**4S – Friday Stop Time**

<b>Range:</b>	00:00 - 23:59	<b>Default:</b>	00:00
---------------	---------------	-----------------	-------

**Description:** Sets the auto-stop time for Friday (24 hour format).

**4T – Saturday Mode**

<b>Options:</b>	Start/Stop Disable (default)	Stop Only Enable
	Start Only Enable	Start/Stop Enable

**Description:** Enables or disables auto-start/stop for Saturday.

**4U – Saturday Start Time**

<b>Range:</b>	00:00 - 23:59	<b>Default:</b>	00:00
---------------	---------------	-----------------	-------

**Description:** Sets the auto-start time for Saturday (24 hour format).

**4V – Saturday Stop Time**

<b>Range:</b>	00:00 - 23:59	<b>Default:</b>	00:00
---------------	---------------	-----------------	-------

**Description:** Sets the auto-stop time for Saturday (24 hour format).

## 9.9 5 Protection Levels

### 5A – Current Imbalance

**Range:** 10% - 50% **Default:** 30%

**Description:** Sets the trip point for current imbalance protection.

### 5B – Current Imbalance Delay

**Range:** 0:00 - 4:00 (minutes:seconds) **Default:** 3 seconds

**Description:** Slows the WSIQ's response to current imbalance, avoiding trips due to momentary fluctuations.

### 5C – Undercurrent

**Range:** 0% - 100% **Default:** 20%

**Description:** Sets the trip point for undercurrent protection, as a percentage of motor full load current. Set to a level between the motor's normal working range and the motor's magnetising (no load) current (typically 25% to 35% of full load current). A setting of 0% disables undercurrent protection.

### 5D – Undercurrent Delay

**Range:** 0:00 - 4:00 (minutes:seconds) **Default:** 5 seconds

**Description:** Slows the WSIQ's response to undercurrent, avoiding trips due to momentary fluctuations.

### 5E – Overcurrent

**Range:** 80% - 600% **Default:** 400%

**Description:** Sets the trip point for overcurrent protection, as a percentage of motor full load current.

### 5F – Overcurrent Delay

**Range:** 0:00 - 1:00 (minutes:seconds) **Default:** 0 second

**Description:** Slows the WSIQ's response to overcurrent, avoiding trips due to momentary overcurrent events.

### 5G – Excess Start Time

**Range:** 0:00 - 4:00 (minutes:seconds) **Default:** 20 seconds

**Description:** Excess start time is the maximum time the WSIQ will attempt to start the motor. If the motor does not transition to Run mode within the programmed limit, the starter will trip. Set for a period slightly longer than required for a normal healthy start. A setting of 0 disables excess start time protection.

### 5H – Restart Delay

**Range:** 00:01 - 60:00 (minutes:seconds) **Default:** 10 seconds

**Description:** The WSIQ can be configured to force a delay between the end of a stop and the beginning of the next start. During the restart delay period, the display shows the time remaining before another start can be attempted.

## 9.10 6 Protection Action

### 6A – *Current Imbalance*

---

<b>Options:</b>	Soft Trip and Log (default)	The soft starter will stop the motor as selected in parameter 2I or 3I <i>Stop Mode</i> , then enter trip state. The trip must be reset before the WSIQ can restart.
	Trip Starter	The soft starter will remove power and the motor will coast to stop. The trip must be reset before the WSIQ can restart.
	Warn and Log	The protection will be written to the event log and the display will show a warning message, but the soft starter will continue to operate.
	Log Only	The protection will be written to the event log but the soft starter will continue to operate.

**Description:** Selects the soft starter's response to each protection. All protection events are written to the event log.

### 6B – *Undercurrent*

---

<b>Options:</b>	Soft Trip and Log (default)	Warn and Log
	Trip Starter	Log Only

**Description:** Selects the soft starter's response to the protection event.

### 6C – *Overcurrent*

---

<b>Options:</b>	Soft Trip and Log (default)	Warn and Log
	Trip Starter	Log Only

**Description:** Selects the soft starter's response to the protection event.

### 6D – *Excess Start Time*

---

<b>Options:</b>	Soft Trip and Log (default)	Warn and Log
	Trip Starter	Log Only

**Description:** Selects the soft starter's response to the protection event.

### 6E – *Input A Trip*

---

<b>Options:</b>	Soft Trip and Log (default)	Warn and Log
	Trip Starter	Log Only

**Description:** Selects the soft starter's response to the protection event.

### 6F – *Input B Trip*

---

<b>Options:</b>	Soft Trip and Log (default)	Warn and Log
	Trip Starter	Log Only

**Description:** Selects the soft starter's response to the protection event.

**6G – Network Communications**

---

<b>Options:</b>	Soft Trip and Log (default)	Warn and Log
	Trip Starter	Log Only
	Stop	

**Description:** Selects the soft starter's response to the protection event. If set to Stop, the WSIQ will perform a soft stop, then can be restarted without a reset.

**6H – Remote Keypad Fault**

---

<b>Options:</b>	Soft Trip and Log (default)	Warn and Log
	Trip Starter	Log Only

**Description:** Selects the soft starter's response to the protection event.

**6I – Frequency**

---

<b>Options:</b>	Soft Trip and Log (default)	Warn and Log
	Trip Starter	Log Only

**Description:** Selects the soft starter's response to the protection event.

**6J – Motor Overtemperature**

---

<b>Options:</b>	Soft Trip and Log (default)	Warn and Log
	Trip Starter	Log Only

**Description:** Selects the soft starter's response to the protection event.

**6K – Motor Thermistor Circuit**

---

<b>Options:</b>	Soft Trip and Log (default)	Warn and Log
	Trip Starter	Log Only

**Description:** Selects the soft starter's response to the protection event.

**6L – Shorted SCR Action**

---

<b>Options:</b>	3-Phase Control Only (default)
	PowerThrough

**Description:** Selects whether the soft starter will allow PowerThrough operation, if the soft starter is damaged on one phase. The soft starter will use two-phase control, allowing the motor to continue operating in critical applications. Refer to *PowerThrough* on page 44 for further information.

**6M – Battery/Clock**

---

<b>Options:</b>	Soft Trip and Log (default)	Warn and Log
	Trip Starter	Log Only

**Description:** Selects the soft starter's response to the protection event.

**6N – Pressure Sensor**

---

<b>Options:</b>	Soft Trip and Log (default)	Warn and Log
	Trip Starter	Log Only

**Description:** Selects the soft starter's response if it detects a fault with the pressure sensor.

**6O – Flow Sensor**

---

<b>Options:</b>	Soft Trip and Log (default)	Warn and Log
	Trip Starter	Log Only

**Description:** Selects the soft starter's response if it detects a fault with the flow sensor.

**6P – Depth Sensor**

---

<b>Options:</b>	Soft Trip and Log (default)	Warn and Log
	Trip Starter	Log Only

**Description:** Selects the soft starter's response if it detects a fault with the depth sensor.

**6Q – High Pressure**

---

<b>Options:</b>	Soft Trip and Log (default)	Warn and Log
	Trip Starter	Log Only

**Description:** Selects the soft starter's response if the pressure exceeds the high pressure trip level (parameter 14A) or the high pressure switch sensor closes.

**6R – Low Pressure**

---

<b>Options:</b>	Soft Trip and Log (default)	Warn and Log
	Trip Starter	Log Only

**Description:** Selects the soft starter's response if the pressure falls below the low pressure trip level (parameter 14D) or the low pressure switch sensor closes.

**6S – High Flow**

---

<b>Options:</b>	Soft Trip and Log (default)	Warn and Log
	Trip Starter	Log Only

**Description:** Selects the soft starter's response if the flow exceeds the high flow trip level (parameter 13A).

**6T – Low Flow**

---

<b>Options:</b>	Soft Trip and Log (default)	Warn and Log
	Trip Starter	Log Only

**Description:** Selects the soft starter's response if the flow falls below the low flow trip level (parameter 13B).

**6U – Flow Switch**

<b>Options:</b>	Soft Trip and Log (default)	Warn and Log
	Trip Starter	Log Only

**Description:** Selects the soft starter's response if the flow sensor closes (switch type sensors only).

**6V – Well Depth**

<b>Options:</b>	Soft Trip and Log (default)	Warn and Log
	Trip Starter	Log Only

**Description:** Selects the soft starter's response if the depth falls below the depth trip level (parameter 16A) or the depth switch sensor closes.

**6W – RTD/PT100 B**

<b>Options:</b>	Soft Trip and Log (default)	Warn and Log
	Trip Starter	Log Only

**Description:** Selects the soft starter's response to the protection event.

**9.11 7 Inputs**

**7A – Input A Function**

<b>Options:</b>	Command Override: Network	Overrides the setting of 1A and sets the command source to the communications network.
	Command Override: Digital	Overrides the setting of 1A and sets the command source to the digital inputs.
	Command Override: Keypad	Overrides the setting of 1A and sets the command source to the remote keypad.
	Input Trip (N/O) (default)	A closed circuit across 13, 14 trips the soft starter.
	Input Trip (N/C)	An open circuit across 13, 14 trips the soft starter.
	Emergency Mode	A closed circuit across 13, 14 activates emergency mode. When the WSIQ receives a start command, it will continue to run until a stop command is received, ignoring all trips and warnings.
	Jog Forward	Activates jog operation in a forward direction.
	Jog Reverse	Activates jog operation in reverse direction.
	Zero Speed Sensor	A closed circuit across 13, 14 indicates to the soft starter that the zero speed detector has opened and the motor has reached a standstill.
	Motor Set Select	A closed circuit across 13, 14 instructs the starter to use the secondary motor configuration for the next start/stop cycle.

**Description:** Selects the function of Input A.

**7B – Input A Trip**

---

<b>Options:</b>	Always Active	A trip can occur at any time when the soft starter is receiving power.
	Operating Only (default)	A trip can occur while the soft starter is running, stopping or starting.
	Run Only	A trip can only occur while the soft starter is running.

**Description:** Selects when an input trip can occur.

**7C – Input A Trip Delay**

---

**Range:** 0:00 - 4:00 (minutes:seconds)      **Default:** 0 second

**Description:** Sets a delay between the input activating and the soft starter tripping.

**7D – Input A Initial Delay**

---

**Range:** 00:00 - 30:00 (minutes:seconds)      **Default:** 0 second

**Description:** Sets a delay before an input trip can occur. The initial delay is counted from the time a start signal is received. The state of the input is ignored until the initial delay has elapsed.

**7E – Input B Function**

---

<b>Options:</b>	Input Trip (N/O) (default)	Jog Reverse
	Input Trip (N/C)	Zero Speed Sensor
	Emergency Mode	Motor Set Select
	Jog Forward	

**Description:** Selects the function of Input B. Refer to parameter 7A *Input A Function* for details.

**7F – Input B Trip**

---

<b>Options:</b>	Always Active
	Operating Only (default)
	Run Only

**Description:** Selects when an input trip can occur.

**7G – Input B Trip Delay**

---

**Range:** 0:00 - 4:00 (minutes:seconds)      **Default:** 0 second

**Description:** Sets a delay between the input activating and the soft starter tripping.

**7H – Input B Initial Delay**

---

**Range:** 00:00 - 30:00 (minutes:seconds)      **Default:** 0 second

**Description:** Sets a delay before an input trip can occur. The initial delay is counted from the time a start signal is received. The state of the input is ignored until the initial delay has elapsed.

**7I – Reset/Enable Logic**

---

**Options:** Normally Closed (default)  
Normally Open

**Description:** Selects whether the reset input (10, 11) is normally open or normally closed.



**NOTE**

If the reset input is active, the starter will not operate.

**7J – Input A Name**

---

**Options:** Input A Trip (default)  
Custom Message

**Description:** Selects a message for the keypad to display when Input A is active. The custom message can be loaded via the USB port. Refer to *USB Save & Load* on page 36 for details.

**7K – Input B Name**

---

**Options:** Input B Trip (default)  
Custom Message

**Description:** Selects a message for the keypad to display when Input B is active.

**9.12 8 Relay Outputs**

**8A – Relay A Function**

---

<b>Options:</b>	Off	Relay A is not used.
	Ready	The relay is closed when the starter is in Ready state.
	Run (default)	The Run output closes when the soft start is complete (when the starting current falls below 120% of the programmed motor full load current) and remains closed until the beginning of a stop (either soft stop or coast to stop).
	Warning	The relay closes when the starter issues a warning (refer to <i>6 Protection Action</i> on page 71).
	Trip	The relay closes when the starter trips (refer to <i>6 Protection Action</i> on page 71).
	Low Current Flag	The relay closes when the low current flag activates while the motor is running (refer to parameter 8G <i>Low Current Flag</i> ).
	High Current Flag	The relay closes when the high current flag activates while the motor is running (refer to parameter 8H <i>High Current Flag</i> ).
	Motor Temperature Flag	The relay closes when the motor temperature flag activates (refer to parameter 8I <i>Motor Temperature Flag</i> ).

Soft Brake Relay    The relay closes when the soft starter receives a stop signal, and remains closed until the end of soft brake.

**Description:** Selects the function of Relay A. Relay A is a changeover relay.

---

#### **8B – Relay A On Delay**

**Range:**        0:00 - 5:00 (minutes:seconds)        **Default:**        0 second

**Description:** Sets the delay for changing the state of Relay A.

---

#### **8C – Relay A Off Delay**

**Range:**        0:00 - 5:00 (minutes:seconds)        **Default:**        0 second

**Description:** Sets the delay for changing the state of Relay A.

---

#### **8D – Relay B Function**

<b>Options:</b>	Off	Low Current Flag
	Ready	High Current Flag
	Run (default)	Motor Temperature Flag
	Warning	Soft Brake Relay
	Trip	

**Description:** Selects the function of Relay B (normally open). Refer to parameter 8A *Relay A Function* for details.

---

#### **8E – Relay B On Delay**

**Range:**        0:00 - 5:00 (minutes:seconds)        **Default:**        0 second

**Description:** Sets the delay for closing Relay B.

---

#### **8F – Relay B Off Delay**

**Range:**        0:00 - 5:00 (minutes:seconds)        **Default:**        0 second

**Description:** Sets the delay for re-opening Relay B.

---

#### **8G – Low Current Flag**

The WSIQ has low and high current flags to give early warning of abnormal operation. The current flags can be configured to indicate an abnormal current level during operation, between the normal operating level and the undercurrent or instantaneous overcurrent trip levels. The flags can signal the situation to external equipment via one of the programmable outputs.

The flags clear when the current returns within the normal operating range by 10% of the programmed flag value.

**Range:**        1% - 100% FLC        **Default:**        50%

**Description:** Sets the level at which the low current flag operates, as a percentage of motor full load current.

---

#### **8H – High Current Flag**

**Range:**        50% - 600% FLC        **Default:**        100%

**Description:** Sets the level at which the high current flag operates, as a percentage of motor full load current.

---

**8I – Motor Temperature Flag**

The WSIQ has a motor temperature flag to give early warning of abnormal operation. The flag can indicate that the motor is operating above its normal operating temperature but lower than the overload limit. The flag can signal the situation to external equipment via one of the programmable outputs.

**Range:** 0% - 160% **Default:** 80%

**Description:** Sets the level at which the motor temperature flag operates, as a percentage of the motor's thermal capacity.

---

**8J – Main Contactor Time**

**Range:** 100 – 2000 milliseconds **Default:** 400 milliseconds

**Description:** Sets the delay period between the starter switching the main contactor output (terminals 33, 34) and beginning the pre-start checks (before a start) or entering the not ready state (after a stop). Set according to the specifications of the main contactor used.

**9.13 9 Analog Output**

---

**9A – Analog Output A**

<b>Options:</b>	Current (% FLC) (default)	Current as a percentage of motor full load current.
	Motor Temp (%)	The motor's temperature, calculated by the thermal model.
	Heatsink Temperature (°C)	The soft starter's temperature, measured at the heatsink.
	Motor pf	Motor power factor, measured by the soft starter.

**Description:** Selects which information will be reported via the analog output.

---

**9B – Analog A Scale**

**Range:** 0-20 mA  
4-20 mA (default)

**Description:** Selects the range of the analog output.

---

**9C – Analog A Maximum Adjustment**

**Range:** 0% - 600% **Default:** 100%

**Description:** Calibrates the upper limit of the analog output to match the signal measured on an external current measuring device.

---

**9D – Analog A Minimum Adjustment**

**Range:** 0% - 600% **Default:** 0%

**Description:** Calibrates the lower limit of the analog output to match the signal measured on an external current measuring device.

## 9.14 10 Display

### 10A – Language

---

<b>Options:</b>	English (default)	Português
	Chinese	Français
	Español	Italiano
	Deutsch	Russian

**Description:** Selects which language the keypad will use to display messages and feedback.

### 10B – Temperature Scale

---

<b>Options:</b>	Celsius (default)
	Fahrenheit

**Description:** Selects whether the WSIQ will display temperatures in degrees Celsius or Fahrenheit.

### 10C – Graph Timebase

---

<b>Options:</b>	30 seconds (default)
	1 minute
	30 minutes
	1 hour

**Description:** Sets the graph time scale. The graph will progressively replace the old data with new data.

### 10D – Graph Maximum Adjustment

---

<b>Range:</b>	0% – 600%	<b>Default:</b>	400%
---------------	-----------	-----------------	------

**Description:** Adjusts the upper limit of the performance graph.

### 10E – Graph Minimum Adjustment

---

<b>Range:</b>	0% – 600%	<b>Default:</b>	0%
---------------	-----------	-----------------	----

**Description:** Adjusts the lower limit of the performance graph.

### 10F – Current Calibration

---

<b>Range:</b>	85% - 115%	<b>Default:</b>	100%
---------------	------------	-----------------	------

**Description:** Calibrates the soft starter's current monitoring circuits to match an external current metering device.

Use the following formula to determine the necessary adjustment:

$$\text{Calibration (\%)} = \frac{\text{Current shown on WSIQ display}}{\text{Current measured by external device}}$$

### 10G – Adjustment Lock

---

<b>Options:</b>	Read & Write (default)	Allows users to alter parameter values in the Programming Menu.
	Read Only	Prevents users altering parameter values in the Programming Menu. Parameter values can still be viewed.

**Description:** Selects whether the keypad will allow parameters to be changed via the Programming Menu.

**10H – User Parameter 1**

<b>Options:</b>	Blank (default)	Displays no data in the selected area, allowing long messages to be shown without overlapping.
	Motor pf	The motor's power factor, measured by the soft starter.
	Mains Frequency	The average frequency measured on three phases.
	Analog Output Value	The value of the analog output (refer to parameters 9A~9D).
	Motor Temp (%)	The motor's temperature, calculated by the thermal model.
	Heatsink Temperature	The soft starter's temperature, measured at the heatsink.
	Bypass Model (%)	The percentage of thermal capacity remaining in the bypass contactor.
	SCR Temperature	The temperature of the SCRs, calculated by the thermal model.
	Rating Capacity (%)	The thermal capacity available in the soft starter for its next start.
	Number of Starts	The number of starts the WSIQ has completed since the start counter was last reset.
	Hours Run	The number of hours the motor has run via the soft starter.
	Pump Pressure	The pressure at the pump, as configured in parameters 12D~12F. This information is only available if the smart card is installed.
	Pump Flow	The flow at the pump, as configured in parameters 12H~12M. This information is only available if the smart card is installed.
	Well Depth	The depth of the well, as configured in parameters 12O~12Q. This information is only available if the smart card is installed.
	Pump Temperature	The pump temperature, as measured by the PT100. This information is only available if the smart card is installed.

**Description:** Selects which information will be displayed on the programmable monitoring screen.



**11F – Devicenet Baud Rate**

---

**Options:** 125 kB (default)  
250 kB  
500 kB

**Description:** Selects the baud rate for DeviceNet communications.

**11G – Profibus Address**

---

**Range:** 1 - 125 **Default:** 1

**Description:** Sets the Profibus network address for the soft starter.

**11H – Gateway Address**

---

**Range:** 0 - 255 **Default:** 192

**Description:** Sets the first component of the network gateway address. The gateway address is set using parameters 11H~11K and the default address is 192.168.0.100.

**11I – Gateway Address 2**

---

**Range:** 0 - 255 **Default:** 168

**Description:** Sets the second component of the network gateway address.

**11J – Gateway Address 3**

---

**Range:** 0 - 255 **Default:** 0

**Description:** Sets the third component of the network gateway address.

**11K – Gateway Address 4**

---

**Range:** 0 - 255 **Default:** 100

**Description:** Sets the fourth component of the network gateway address.

**NOTE**

The network address can also be set via the Network Address options in the Setup Tools. Refer to *Network Address* on page 38 for details.

**11L – IP Address**

---

**Range:** 0 - 255 **Default:** 192

**Description:** Sets the first component of the soft starter's IP address, for Ethernet communications. The IP address is set using parameters 11L~11O and the default address is 192.168.0.2.

**11M – IP Address 2**

---

**Range:** 0 - 255 **Default:** 168

**Description:** Sets the second component of the soft starter's IP address, for Ethernet communications.

**11N – IP Address 3**

---

**Range:** 0 - 255 **Default:** 0

**Description:** Sets the third component of the soft starter's IP address, for Ethernet communications.

**11O – IP Address 4**

---

**Range:** 0 - 255 **Default:** 2

**Description:** Sets the fourth component of the soft starter's IP address, for Ethernet communications.

**NOTE**

The network address can also be set via the Network Address options in the Setup Tools. Refer to *Network Address* on page 38 for details.

**11P – Subnet Mask**

---

**Range:** 0 - 255 **Default:** 255

**Description:** Sets the first component of the network subnet mask, for Ethernet communications. The subnet mask is set using parameters 11P~11S and the default mask is 255.255.255.0.

**11Q – Subnet Mask 2**

---

**Range:** 0 - 255 **Default:** 255

**Description:** Sets the second component of the network subnet mask, for Ethernet communications.

**11R – Subnet Mask 3**

---

**Range:** 0 - 255 **Default:** 255

**Description:** Sets the third component of the network subnet mask, for Ethernet communications.

**11S – Subnet Mask 4**

---

**Range:** 0 - 255 **Default:** 0

**Description:** Sets the fourth component of the network subnet mask, for Ethernet communications.

**NOTE**

The network address can also be set via the Network Address options in the Setup Tools. Refer to *Network Address* on page 38 for details.

**11T – DHCP**

---

**Options:** Disable (default)  
Enable

**Description:** Selects whether the communications card will accept an IP address assigned by DHCP.

**NOTE**

DHCP addressing is available with Modbus TCP and Ethernet/IP. DHCP addressing is not supported with Profinet.

**11U – Location ID**

---

**Range:** 0 - 65535 **Default:** 0**Description:** Sets the soft starter's unique location ID.**9.16 12 Pump Input Configuration****NOTE**

The parameters in this group are only active if a smart card is installed.

**12A – Auto-Reset Count**

---

**Range:** 0 – 5 **Default:** 0**Description:** Sets how many times the soft starter will auto-reset, if it continues to trip.

The reset counter increases by one each time the soft starter auto-resets, and resets after a successful start.

Setting 12A to zero disables auto-reset.

**NOTE**

Auto-reset will reset trips from any source, not just from the smart card.

**12B – Auto-Reset Delay**

---

**Range:** 0:05 - 15:00 (minutes:seconds) **Default:** 5 seconds**Description:** Sets a delay before the WSIQ will auto-reset a trip.**12C – Pressure Sensor Type**

---

**Options:** None (default)  
Switch  
Analog**Description:** Selects which type of sensor is associated with the pressure sensor input on the smart card.**12D – Pressure Units**

---

**Options:** Bar  
kPa (default)  
Psi**Description:** Selects which units the sensor will use to report the measured pressure.**12E – Pressure at 4 mA**

---

**Range:** 0 – 5000 **Default:** 0**Description:** Calibrates the soft starter to the 4 mA (0%) level of the pressure sensor input.

**12F – Pressure at 20 mA**

---

**Range:** 0 – 5000 **Default:** 0**Description:** Calibrates the soft starter to the 20 mA (100%) level of the pressure sensor input.**12G – Flow Sensor Type**

---

**Options:** None (default) Pulses per minute  
Switch Pulses per unit  
Analog**Description:** Selects which type of sensor is associated with the flow sensor input on the smart card.**12H – Flow Units**

---

**Options:** litres/second (default)  
litres/minute  
gallons/second  
gallons/minute**Description:** Selects which units the sensor will use to report the measured flow.**12I – Flow at 4 mA**

---

**Range:** 0 – 5000 **Default:** 0**Description:** Calibrates the soft starter to the 4 mA (0%) level of the flow sensor input.**12J – Flow at 20 mA**

---

**Range:** 0 – 5000 **Default:** 0**Description:** Calibrates the soft starter to the 20 mA (100%) level of the flow sensor input.**12K – Units per Minute at Max Flow**

---

**Range:** 0 – 20000 **Default:** 0**Description:** Calibrates the soft starter to the maximum flow volume of the flow sensor.**12L – Pulses per Minute at Max Flow**

---

**Range:** 0 – 5000 **Default:** 0**Description:** Calibrates the soft starter to the maximum flow volume of the flow sensor.**12M – Units per Pulse**

---

**Range:** 0 – 1000 **Default:** 0**Description:** Set to match how many units the flow sensor will measure for each pulse.

**12N – Depth Sensor Type**

**Options:** None (default)  
Switch  
Analog

**Description:** Selects which type of sensor is associated with the depth sensor input on the smart card.

**12O – Depth Units**

**Options:** metres (default)  
feet

**Description:** Selects which units the sensor will use to report the measured depth.

**12P – Depth at 4 mA**

**Range:** 0 – 1000 **Default:** 0

**Description:** Calibrates the soft starter to the 4 mA (0%) level of the depth sensor input.

**12Q – Depth at 20 mA**

**Range:** 0 – 1000 **Default:** 0

**Description:** Calibrates the soft starter to the 20 mA (100%) level of the depth sensor input.

**9.17 13 Flow Protection****NOTE**

The parameters in this group are only active if a smart card is installed.

Flow protection uses terminals B33, B34 or C23, C24 on the smart card.

**13A – High Flow Trip Level**

**Range:** 0 – 5000 **Default:** 0

**Description:** Sets the trip point for high flow protection.

**13B – Low Flow Trip Level**

**Range:** 1 – 5000 **Default:** 5

**Description:** Sets the trip point for low flow protection.

**13C – Flow Start Delay**

**Range:** 00:00:50 - 30:00:00 mm:ss:ms **Default:** 0.5 seconds

**Description:** Sets a delay before a flow protection trip can occur. The delay is counted from the time a start signal is received. The flow level is ignored until the start delay has elapsed.

**13D – Flow Response Delay**

**Range:** 00:00:10 - 30:00:00 mm:ss:ms **Default:** 0.5 seconds

**Description:** Sets a delay between the flow passing the high or low flow trip levels, and the soft starter tripping.

## 9.18 14 Pressure Protection



### NOTE

The parameters in this group are only active if a smart card is installed.

Pressure protection uses terminals B23, B24 or C33, C34, C43, C44 on the smart card.

### 14A – High Pressure Trip Level

---

**Range:** 0 – 5000 **Default:** 10

**Description:** Sets the trip point for high pressure protection.

### 14B – High Pressure Start Delay

---

**Range:** 00:00:10 – 30:00:00 mm:ss:ms **Default:** 0.5 seconds

**Description:** Sets a delay before a high pressure protection trip can occur. The delay is counted from the time a start signal is received. The pressure is ignored until the start delay has elapsed.

### 14C – High Pressure Response Delay

---

**Range:** 00:00:10 – 30:00:00 mm:ss:ms **Default:** 0.5 seconds

**Description:** Sets a delay between the pressure passing the high pressure trip level, and the soft starter tripping.

### 14D – Low Pressure Trip Level

---

**Range:** 0 – 5000 **Default:** 5

**Description:** Sets the trip point for high pressure protection.

### 14E – Low Pressure Start Delay

---

**Range:** 00:00:10 – 30:00:00 mm:ss:ms **Default:** 0.5 seconds

**Description:** Sets a delay before a low pressure protection trip can occur. The delay is counted from the time a start signal is received. The pressure is ignored until the start delay has elapsed.

### 14F – Low Pressure Response Delay

---

**Range:** 00:00:10 – 30:00:00 mm:ss:ms **Default:** 0.5 seconds

**Description:** Sets a delay between the pressure passing the low pressure trip level, and the soft starter tripping.

## 9.19 15 Pressure Control

Pressure control use terminals B23, B24 on the smart card.



**NOTE**

The parameters in this group are only active if a smart card is installed.

### 15A – Pressure Control Mode

---

<b>Options:</b>	Off (default)	The WSIQ will not use the pressure sensor to control soft starting.
	Falling Pressure Start	The WSIQ will start when the pressure drops below the level selected in parameter 15B <i>Start Pressure Level</i> .
	Rising Pressure Start	The WSIQ will start when the pressure rises above the level selected in parameter 15B <i>Start Pressure Level</i> .

**Description:** Selects how the WSIQ will use data from the pressure sensor to control the motor.

### 15B – Start Pressure Level

---

**Range:** 1 – 5000 **Default:** 5

**Description:** Sets the pressure level to trigger the WSIQ to perform a soft start.

### 15C – Start Response Delay

---

**Range:** 00:00:10 – 30:00:00 mm:ss:ms **Default:** 0.5 seconds

**Description:** Sets a delay between the pressure passing the pressure control start level, and the WSIQ performing a soft start.

### 15D – Stop Pressure Level

---

**Range:** 0 – 5000 **Default:** 10

**Description:** Sets the pressure level to trigger the WSIQ to stop the motor.

### 15E – Stop Response Delay

---

**Range:** 00:00:10 – 30:00:00 mm:ss:ms **Default:** 0.5 seconds

**Description:** Sets a delay between the pressure passing the pressure control stop level, and the WSIQ stopping the motor.

## 9.20 16 Depth Protection



### NOTE

The parameters in this group are only active if a smart card is installed.

Depth protection uses terminals B13, B14 or C13, C14 on the smart card.

### 16A – Depth Trip Level

---

**Range:** 0 – 1000 **Default:** 5

**Description:** Sets the trip point for depth protection.

### 16B – Depth Reset Level

---

**Range:** 0 – 1000 **Default:** 10

**Description:** Sets the level for the WSIQ to auto-reset a depth trip.

### 16C – Depth Start Delay

---

**Range:** 00:00:10 – 30:00:00 mm:ss:ms **Default:** 0.5 seconds

**Description:** Sets a delay before a depth protection trip can occur. The delay is counted from the time a start signal is received. The depth input is ignored until the start delay has elapsed.

### 16D – Depth Response Delay

---

**Range:** 00:00:10 – 30:00:00 mm:ss:ms **Default:** 0.5 seconds

**Description:** Sets a delay between the depth passing the depth protection trip level, and the soft starter tripping.

## 9.21 17 Thermal Protection



### NOTE

The parameters in this group are only active if a smart card is installed.

### 17A – Temperature Sensor Type

---

**Options:** None (default)  
PT100

**Description:** Selects which type of sensor is associated with the temperature sensor input on the smart card.

### 17B – Temperature Trip Level

---

**Range:** 0° – 240° **Default:** 40°

**Description:** Sets the trip point for temperature protection. Use parameter 10B *Temperature Scale* to configure the temperature scale.

## 9.22 20 Advanced

### 20A – Tracking Gain

**Range:** 1% - 200%

**Default:** 50%

**Description:** Fine-tunes the behaviour of the adaptive control algorithm.

### 20B – Pedestal Detect

**Range:** 0% - 200%

**Default:** 80%

**Description:** Adjusts the behaviour of the adaptive control algorithm for soft stop.

### 20C – Bypass Contactor Delay

**Range:** 100 – 2000 milliseconds

**Default:** 150 milliseconds

**Description:** Sets the starter to match the bypass contactor closing/opening time. Set according to the specifications of the bypass contactor used. If this time is too short, the starter will trip.

### 20D – Model Rating

**Range:** 0020 ~ 0580

**Default:** Model dependent

**Description:** The soft starter’s internal model reference, as shown on the silver label on the side of the unit ( **1** ).

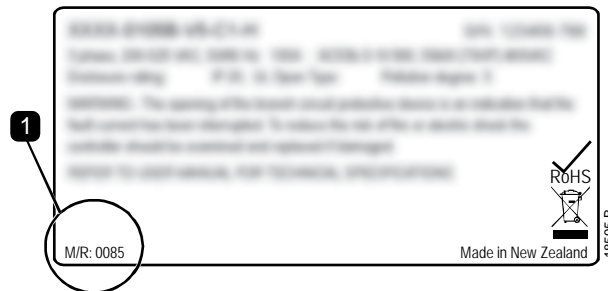

**NOTE**

This parameter can only be adjusted by authorised servicing agents.

### 20E – Screen Timeout

**Options:** 1 minute (default)  
2 minutes  
3 minutes

4 minutes  
5 minutes

**Description:** Sets the timeout for the menu to automatically close if no keypad activity is detected.

# 10 Application Examples

## 10.1 Smart Card - Pump Control and Protection

The WSIQ smart card is ideal for applications with extensive external inputs, such as pumping situations where external sensors provide additional protection to the pump and motor.

In this example, the WSIQ controls a bore pump via scheduled start/stop operation. The control panel is fitted with a three-way selector switch allowing Auto Run, Stop or Manual Run. Three 4-20 mA transducers are used to monitor water depth, pipe pressure and flow.

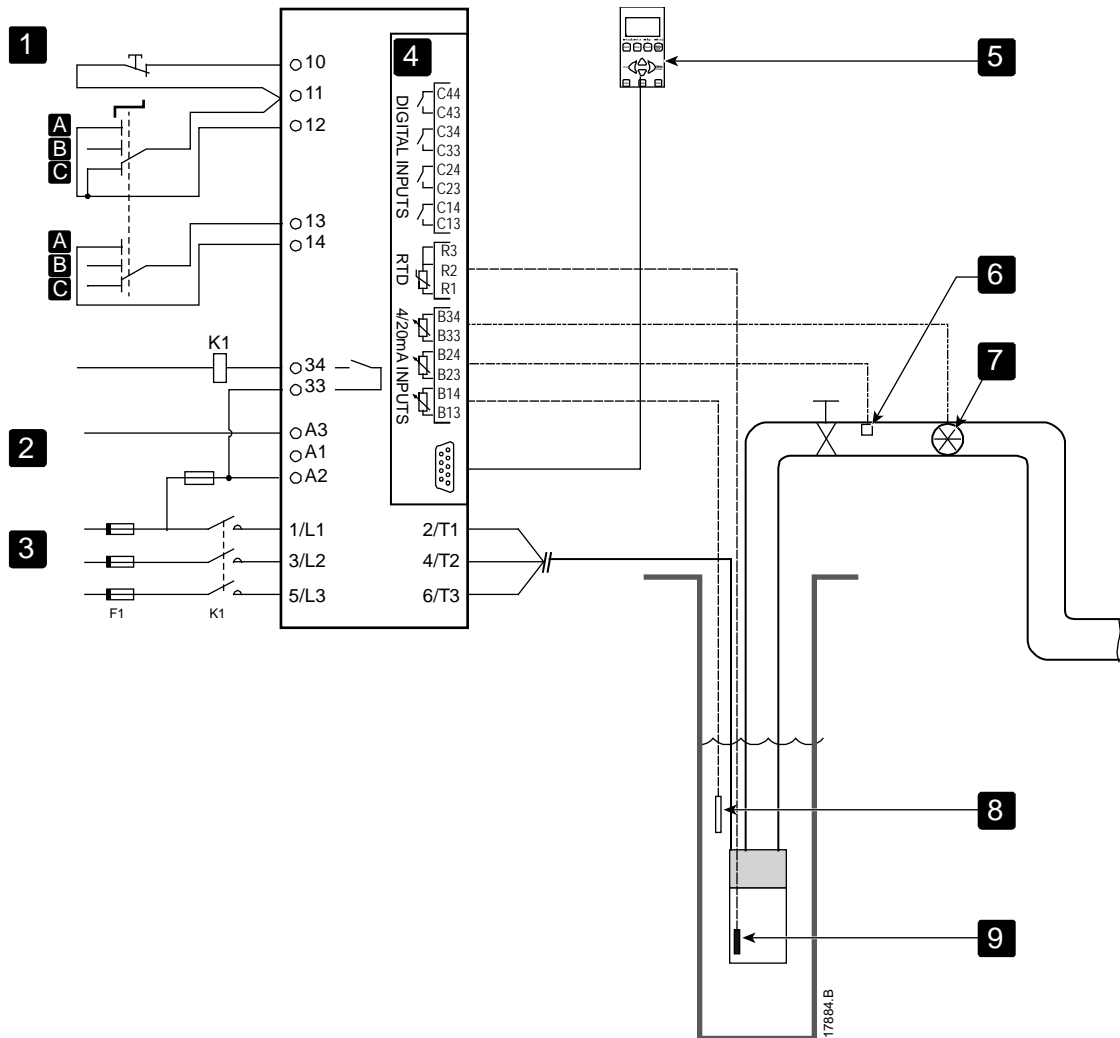

<b>1</b>	Digital inputs
<b>A</b>	Manual start
<b>B</b>	Manual stop
<b>C</b>	Automatic operation (scheduled start/stop)
<b>2</b>	Control voltage
<b>3</b>	Three-phase supply
<b>4</b>	Smart card
<b>5</b>	Remote keypad (optional)
<b>6</b>	Pressure sensor
<b>7</b>	Flow sensor
<b>8</b>	Depth sensor
<b>9</b>	Temperature sensor

K1	Main contactor
10, 11	Reset input
11, 12	Start/stop input
13, 14	Programmable input A (set = Command Override: Digital)
33, 34	Main contactor output
R1, R2, R3	Motor temperature protection
B33, B34	Flow protection
B23, B24	Pressure protection
B13, B14	Depth protection

## Parameter settings:

- Parameter 1A *Command Source*: select 'Smart Card + Clock'.
- Parameters 4A~4V Auto-Start/Stop: Set as required.
- Parameter 7A *Input A Function*: select 'Command Override: Digital'.
- Parameters 12A~12Q Pump Input Configuration: Set as required.
- Parameters 13A~13D Flow Protection: Set as required.
- Parameters 14A~14F Pressure Protection: Set as required.
- Parameters 16A~16D Depth Protection: Set as required.
- Parameters 17A~17B Thermal Protection: Set as required.

### 10.2 Smart Card - Level Controlled Pump Activation

The WSIQ smart card can be used to control start/stop activation of the starter, based on information from external inputs.

In this example, the WSIQ controls a pump which fills a tank, with maximum and minimum water levels. A pressure sensor is used to monitor the level of water in the tank and trigger the pump to fill the tank when water drops below the minimum level, and shut off the pump when the maximum water level is reached.

A three-way selector switch allows the user to override sensor-based control, and manually start or stop the motor.

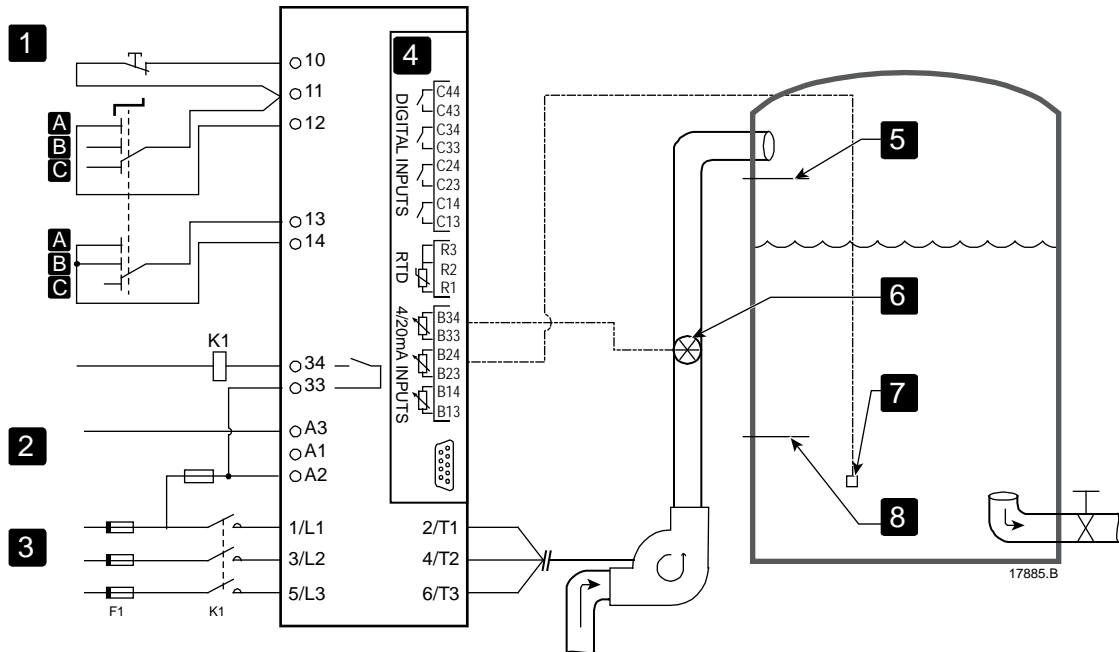

1	Digital inputs
A	Manual start
B	Manual stop
C	Automatic operation (level-controlled)
2	Control voltage
3	Three-phase supply
4	Smart card
5	Maximum water level
6	Flow sensor
7	Pressure sensor
8	Minimum water level

K1	Main contactor
10, 11	Reset input
11, 12	Start/stop input
13, 14	Programmable input A (set = Command Override: Digital)
33, 34	Main contactor output
B33, B34	Flow protection
B23, B24	Pressure or depth based control

Parameter settings:

- Parameter 1A *Command Source*: select 'Smart Card'.
- Parameter 7A *Input A Function*: select 'Command Override: Digital'.
- Parameters 12A~12Q *Pump Input Configuration*: Set as required.
- Parameters 13A~13D *Flow Protection*: Set as required.
- Parameters 15A~15E *Pressure Control*: Set as required.

# 11 Troubleshooting

## 11.1 Protection Responses

When a protection condition is detected, the WSIQ will write this to the event log and may also trip or issue a warning. The soft starter's response depends on the Protection Action setting (parameter group 6).

Some protection responses cannot be adjusted by the user. These trips are usually caused by external events (such as phase loss) or by a fault within the soft starter. These trips do not have associated parameters and cannot be set to Warn or Log. If the WSIQ trips you will need to identify and clear the condition that triggered the trip, then reset the soft starter before restarting. To reset the starter, press the **RESET** button on the keypad or activate the Reset remote input.

If the WSIQ has issued a warning, the soft starter will reset itself once the cause of the warning has been resolved.

## 11.2 Trip Messages

Display	Possible cause/Suggested solution
2 Phase - Damaged SCR	This message is displayed if the soft starter tripped on “ Lx-Tx shorted” during the pre-start checks and PowerThrough is enabled. It indicates that the starter now operates in PowerThrough mode (2-phase control only). Check for either a shorted SCR or a short within the bypass contactor. Related parameters: 6L
Battery/clock	A verification error has occurred on the real time clock, or the backup battery voltage is low. If the battery is low and the power is off, date/time settings will be lost. The WSIQ will continue to soft start and soft stop correctly. Reprogram the date and time. The battery is not removable. In order to replace the battery, the main control PCB must be replaced. Related parameters: 6M
Bypass overload	This trip is not adjustable. Bypass overload protection protects the soft starter from severe operating overloads while running. The soft starter will trip if it detects overcurrent at 600% of the contactor rating. Related parameters: None
Current imbalance	Current imbalance can be caused by problems with the motor, the environment or the installation, such as: <ul style="list-style-type: none"> <li>· An imbalance in the incoming mains voltage</li> <li>· A problem with the motor windings</li> <li>· A light load on the motor</li> <li>· A phase loss on input terminals L1, L2 or L3 during Run mode</li> <li>· An SCR that has failed open circuit. A failed SCR can only be definitely diagnosed by replacing the SCR and checking the starter's performance.</li> </ul> Related parameters: 5A, 5B, 6A

Display	Possible cause/Suggested solution
Current Read Err Lx	Where 'X' is 1, 2 or 3. Internal fault (PCB fault). The output from the CT circuit is not close enough to zero when the SCRs are turned off. Contact your local supplier for advice. Related parameters: None
Depth Sensor	The Smart Module has detected a fault with the depth sensor. Related parameters: 6N, 12N
EEPROM fail	An error occurred loading data from the EEPROM to RAM when the keypad powered up. If the problem persists, contact your local distributor. Related parameters: None
Excess start time	Excess start time trip can occur in the following conditions: <ul style="list-style-type: none"> <li>· parameter 1B <i>Motor Full Load Current</i> is not appropriate for the motor</li> <li>· parameter 2D <i>Current Limit</i> has been set too low</li> <li>· parameter 2B <i>Start Ramp Time</i> has been set greater than the setting for 5G <i>Excess Start Time</i> setting</li> </ul> parameter 2B <i>Start Ramp Time</i> is set too short for a high inertia load when using Adaptive Control Related parameters: 1B, 2B, 2D, 3B, 3D
Firing Fail Px	Where 'X' is phase 1, 2 or 3. The SCR did not fire as expected. The SCR may be faulty or there may be an internal wiring fault. Related parameters: None
FLC too high	If the soft starter is connected to the motor using inside delta configuration, the soft starter may not be correctly detecting the connection. Contact your local supplier for advice. Related parameters: None
Flow Sensor	The Smart Module has detected a fault with the flow sensor. Related parameters: 6M, 12G
Flow Switch	The flow switch sensor (smart card terminals C23, C24) has closed. Related parameters: 6S, 12G
Frequency	This trip is not adjustable. The mains frequency has gone beyond the specified range. Check for other equipment in the area that could be affecting the mains supply, particularly variable speed drives and switch mode power supplies (SMPS). If the WSIQ is connected to a generator set supply, the generator may be too small or could have a speed regulation problem. Related parameters: 6I

Display	Possible cause/Suggested solution
Heatsink overtemperature	<ul style="list-style-type: none"> <li>· Check that bypass contactors are operating.</li> <li>· Check that cooling fans are operating (models WSIQ-0064BP~WSIQ-0580BP).</li> <li>· If mounted in an enclosure, check if ventilation is adequate.</li> <li>· The WSIQ must be mounted vertically.</li> </ul> <p>Related parameters: None</p>
High Flow	<p>The flow sensor connected to the smart card has activated high flow protection.</p> <p>Related parameters: 6Q, 12G, 12I, 12J, 13A, 13C, 13D</p>
High Pressure	<p>The pressure sensor connected to the smart card has activated high pressure protection.</p> <p>Related parameters: 6O, 12C, 12E, 12F, 14A, 14B, 14C</p>
Input A trip Input B trip	<p>The soft starter's programmable input is set to a trip function and has activated. Resolve the trigger condition.</p> <p>Related parameters: 7A, 7B, 7C, 7D, 7E, 7F, 7G, 7H</p>
Instantaneous overcurrent	<p>This trip is not adjustable.</p> <p>The current on all three phases has exceeded 7.2 times the value of parameter 1B <i>Motor Full Load Current</i>.</p> <p>Causes can include a locked rotor condition or an electrical fault in the motor or cabling.</p> <p>Related parameters: None</p>
Internal fault x	<p>Where 'X' is a number.</p> <p>This trip is not adjustable.</p> <p>The WSIQ has tripped on an internal fault. Contact your local supplier with the fault code (X).</p>
Keypad disconnected	<p>Parameter 1A <i>Command Source</i> is set to Remote Keypad but the WSIQ cannot detect a remote keypad.</p> <p>If a remote keypad is installed, check the cable is firmly connected to the soft starter.</p> <p>If no remote keypad is installed, change the setting of parameter 1A.</p> <p>Related parameters: 1A</p>
L1 phase loss L2 phase loss L3 phase loss	<p>This trip is not adjustable.</p> <p>During pre-start checks the starter has detected a phase loss as indicated.</p> <p>In run state, the starter has detected that the current on the affected phase has dropped below 2% of the programmed motor FLC for more than 1 second, indicating that either the incoming phase or connection to the motor has been lost.</p> <p>Check the supply and the input and output connections at the starter and at the motor end.</p> <p>Related parameters: None</p>

Display	Possible cause/Suggested solution
L1-T1 shorted L2-T2 shorted L3-T3 shorted	During pre-start checks the starter has detected a shorted SCR or a short within the bypass contactor as indicated. Consider using PowerThrough to allow operation until the starter can be repaired. Related parameters: 6L
Low Control Volts	The WSIQ has detected a drop in the internal control voltage. <ul style="list-style-type: none"> <li>· Check the external control supply (A1, A2, A3) and reset the starter.</li> </ul> If the external control supply is stable: <ul style="list-style-type: none"> <li>· the 24 V supply on the main control PCB may be faulty; or</li> <li>· the bypass driver PCB may be faulty. Contact your local supplier for advice.</li> </ul> This protection is not active in Ready state. Related parameters: None
Low Flow	The flow sensor connected to the smart card has activated low flow protection. Related parameters: 6R, 12G, 12I, 12J, 13B, 13C, 13D
Low Pressure	The pressure sensor connected to the smart card has activated low pressure protection. Related parameters: 6P, 12C, 12E, 12F, 14D, 14E, 14F
Low Water	The depth sensor connected to the smart card has activated depth protection. Related parameters: 6T, 12N, 12P, 12Q, 16A, 16B, 16C
Motor overload	The motor has reached its maximum thermal capacity. Overload can be caused by: <ul style="list-style-type: none"> <li>· The soft starter protection settings not matching the motor thermal capacity</li> <li>· Excessive starts per hour or start duration</li> <li>· Excessive current</li> <li>· Damage to the motor windings</li> </ul> Resolve the cause of the overload and allow the motor to cool. Related parameters: 1B, 1C, 1D, 1E, 5G, 6D  <div style="border: 1px solid black; padding: 5px; margin-top: 10px;"> <p><b>NOTE</b></p> <p>Parameters 1C, 1D and 1E determine the trip current for motor overload protection. The default settings of parameters 1C, 1D and 1E provide Motor Overload Protection: Class 10, Trip Current 105% of FLA (full load amperage) or equivalent.</p> </div>

Display	Possible cause/Suggested solution
Motor Connection Tx	<p>Where 'X' is 1, 2 or 3.                      The motor is not connected correctly to the soft starter.</p> <ul style="list-style-type: none"> <li>· Check individual motor connections to the soft starter for power circuit continuity.</li> <li>· Check connections at the motor terminal box.</li> </ul> <p>This trip is not adjustable.                      Related parameters: None</p>
Motor thermistor	<p>The motor thermistor input has been enabled and:</p> <ul style="list-style-type: none"> <li>· The resistance at the thermistor input has exceeded 3.6 kΩ for more than one second.</li> <li>· The motor winding has overheated. Identify the cause of the overheating and allow the motor to cool before restarting.</li> <li>· The motor thermistor input has been opened.</li> </ul> <p>If thermistors have previously been connected to the WSIQ but are no longer required, use the Thermistor Reset function to disable the thermistor.                      Related parameters: 6J</p>
Network communication	<p>There is a network communication problem, or the network master may have sent a trip command to the starter. Check the network for causes of communication inactivity.                      Related parameters: 6G</p>
Not ready	<ul style="list-style-type: none"> <li>· The reset input may be active. If the reset input is active, the starter will not operate.</li> <li>· The soft starter may be waiting for the restart delay to elapse. The length of the restart delay is controlled by parameter 5H <i>Restart Delay</i>.</li> </ul> <p>Related parameters: 5H</p>
Overcurrent	<p>The current has exceeded the level set in parameter 5E <i>Overcurrent</i> for longer than the time set in parameter 5F <i>Overcurrent Delay</i>. Causes can include a momentary overload condition.                      Related parameters: 5E, 5F, 6C</p>
Parameter out of range	<p>This trip is not adjustable.</p> <ul style="list-style-type: none"> <li>· A parameter value is outside the valid range. The keypad will indicate the first invalid parameter.</li> <li>· An error occurred loading data from the EEPROM to RAM when the keypad powered up.</li> <li>· The parameter set or values in the keypad do not match the parameters in the starter.</li> <li>· "Load User Set" has been selected but no saved file is available.</li> </ul> <p>Reset the fault. The starter will load the default settings. If the problem persists, contact your local distributor.                      Related parameters: None</p>

Display	Possible cause/Suggested solution
Phase sequence	Mains voltage must be connected to the soft starter's input terminals (L1, L2, L3) in positive phase sequence. Check the phase sequence on L1, L2, L3. Related parameters: None
Power loss	This trip is not adjustable. The starter is not receiving mains supply on one or more phases when a Start Command is given. Check that the main contactor closes when a start command is given, and remains closed until the end of a soft stop. Check the fuses. If testing the soft starter with a small motor, it must draw at least 2% of its minimum FLC setting on each phase. Related parameters: None
Pressure Sensor	The Smart Module has detected a fault with the pressure sensor. Related parameters: 6L, 12C
Rating Capacity	The WSIQ is operating beyond its safe capacity. Allow the starter to cool. Related parameters: None
RTD Circuit	The RTD input on the smart card is open circuit or short circuit. Related parameters: 6U, 17B
SCR Itsm	The SCR current surge rating has been exceeded. Related parameters: None
SCR overtemperature	The temperature of the SCRs, calculated by the thermal model, is too high to allow further operation. Wait for the starter to cool. Related parameters: None
Starter communication	There is a problem with the connection between the soft starter and the optional expansion card. Remove and reinstall the card. If the problem persists, contact your local distributor. Related parameters: 6G
Thermistor circuit	The thermistor input has been enabled and: <ul style="list-style-type: none"> <li>· The resistance at the input has fallen below 20 <math>\Omega</math> (the cold resistance of most thermistors will be over this value) or</li> <li>· A short circuit has occurred. Check and resolve this condition.</li> </ul> Related parameters: None
Time-overcurrent	The WSIQ is internally bypassed and has drawn high current during running. (The 10A protection curve trip has been reached or the motor current has risen to 600% of the motor FLC setting.) Related parameters: None
Undercurrent	The motor has experienced a sharp drop in current, caused by loss of load. Causes can include broken components (shafts, belts or couplings), or a pump running dry. Related parameters: 5C, 5D, 6B

Display	Possible cause/Suggested solution
Unsupported option	The selected function is not available (eg jog is not supported in inside delta configuration). Related parameters: None
VZC Fail Px	Where 'X' is 1, 2 or 3. Internal fault (PCB fault). Contact your local supplier for advice. Related parameters: None
Zero Speed Detect	The zero speed input has not closed within the expected duration of a soft stop. <ul style="list-style-type: none"> <li>Check the zero speed sensor is operating correctly.</li> <li>Check that parameters <i>2Q Brake Current Limit</i> and <i>5G Excess Start Time</i> are appropriate for the application.</li> </ul> Related parameters: 2Q, 3Q, 5G

### 11.3 General Faults

This table describes situations where the soft starter does not operate as expected but does not trip or give a warning.

Symptom	Probable Cause
Starter "Not Ready"	<ul style="list-style-type: none"> <li>The reset input may be active. If the reset input is active, the starter will not operate.</li> </ul>
The soft starter does not respond to the <b>START</b> or <b>RESET</b> button on the keypad.	<ul style="list-style-type: none"> <li>The soft starter will only accept commands from the keypad if parameter <i>1A Command Source</i> is set to Remote Keypad. Check that the Local LED on the starter is on.</li> </ul>
The soft starter does not respond to commands from the control inputs.	<ul style="list-style-type: none"> <li>The soft starter will only accept commands from the inputs if parameter <i>1A Command Source</i> is set to Digital Input. Check the setting of 1A.</li> <li>The control wiring may be incorrect. Check that the remote start, stop and reset inputs are configured correctly (refer to <i>Start/Stop</i> on page 27 for details).</li> <li>The signals to the remote inputs may be incorrect. Test the signalling by activating each input signal in turn.</li> </ul>
The soft starter does not respond to a start command from either the keypad or the digital inputs.	<ul style="list-style-type: none"> <li>The soft starter may be waiting for the restart delay to elapse. The length of the restart delay is controlled by parameter <i>5H Restart Delay</i>.</li> <li>The motor may be too hot to permit a start. The soft starter will only permit a start when it calculates that the motor has sufficient thermal capacity to complete the start successfully. Wait for the motor to cool before attempting another start.</li> <li>The reset input may be active. If the reset input is active, the starter will not operate.</li> <li>The soft starter may be waiting for control signals via the communications network (parameter 1A</li> </ul>

Symptom	Probable Cause
	<p><i>Command Source = Network</i>).</p> <ul style="list-style-type: none"> <li>The WSIQ may be waiting for a scheduled auto-start (parameter 1A <i>Command Source = Clock</i>).</li> </ul>
Erratic and noisy motor operation.	<ul style="list-style-type: none"> <li>If the soft starter is connected to the motor using inside delta configuration, the soft starter may not be correctly detecting the connection. Contact your local supplier for advice.</li> </ul>
Remote keypad shows message "awaiting data"	The keypad is not receiving data from the control PCB. Check the cable connection.
The soft starter does not control the motor correctly during starting.	<ul style="list-style-type: none"> <li>Start performance may be unstable when using a low <i>Motor Full Load Current</i> setting (parameter 1B).</li> <li>Power factor correction (PFC) capacitors must be installed on the supply side of the soft starter and must be disconnected during starting and stopping. To use the WSIQ to control power factor correction, connect the PFC contactor to a programmable relay set to Run.</li> <li>High levels of harmonics on the mains supply can affect soft starter performance. If variable speed drives are installed nearby, check they are properly grounded and filtered.</li> </ul>
Motor does not reach full speed.	<ul style="list-style-type: none"> <li>If the start current is too low, the motor will not produce enough torque to accelerate to full speed. The soft starter may trip on excess start time.</li> </ul> <p> <b>NOTE</b> Make sure the motor starting parameters are appropriate for the application and that you are using the intended motor starting profile. If a programmable input is set to Motor Set Select, check that the corresponding input is in the expected state.</p> <ul style="list-style-type: none"> <li>The load may be jammed. Check the load for severe overloading or a locked rotor situation.</li> </ul>
Soft stop ends too quickly.	<ul style="list-style-type: none"> <li>The soft stop settings may not be appropriate for the motor and load. Review the soft stop settings.</li> <li>If the motor is very lightly loaded, soft stop will have limited effect.</li> </ul>
After selecting Adaptive Control the motor used an ordinary start and/or the second start was different to the first.	<ul style="list-style-type: none"> <li>The first Adaptive Control start is actually 'Constant Current' so that the starter can learn from the motor characteristics. Subsequent starts use Adaptive Control.</li> </ul>

Symptom	Probable Cause
PowerThrough does not operate when selected.	<ul style="list-style-type: none"> <li>· The starter will trip on Lx-Tx Shorted on the first start attempt after control power is applied. PowerThrough will not operate if control power is cycled between starts.</li> </ul>
Parameter settings cannot be stored.	<ul style="list-style-type: none"> <li>· Make sure you are saving the new value by pressing the <b>ENTER</b> button after adjusting a parameter setting. If you press <b>EXIT</b>, the change will not be saved. The WSIQ does not display a confirmation.</li> <li>· Check that the adjustment lock (parameter 10G) is set to Read &amp; Write. If the adjustment lock is set to Read Only, settings can be viewed but not changed.</li> </ul>
USB Full	<ul style="list-style-type: none"> <li>· The USB drive may not have enough free space available for the selected function.</li> <li>· The file system on the USB drive may not be compatible with the soft starter. WSIQ supports FAT32 file systems. WSIQ USB functions are not compatible with NTFS file systems.</li> </ul>
USB Missing	A USB function has been selected in the menu, but the product cannot detect a USB drive. Check that the USB drive has been inserted in the port.
File Missing	A USB function has been selected in the menu, but the required file cannot be found. Save/Load Master Parameters uses a file called Master_Parameters.par, at the top level of the USB drive. For these functions to work correctly, do not move or rename this file.
File Not Valid	A USB function has been selected in the menu, but the file is not valid.
File Empty	A USB function has been selected in the menu and the file has been found, but does not contain the expected content.
Rating Not Valid	The value selected for parameter 20D <i>Model Rating</i> does not match the soft starter. Set parameter 20D to match the rating shown on the WSIQ nameplate label (on the side of the unit).







