



WSB USER MANUAL



WorldWide Electric Corporation
Phone: 1-800-808-2131
Fax: 1-800-711-1616
www.worldwideelectric.net

Contents

1	About This Manual	4
1.1	Disclaimer	4
2	Caution Statements	5
2.1	Electrical shock risk.....	5
2.2	Unexpected Operation	6
2.3	Avertissements à l'attention des clients canadiens	7
3	System Design	9
3.1	Feature List	9
3.2	Model Code.....	10
3.3	Model Selection.....	10
3.4	Current Ratings.....	10
3.5	Dimensions and Weights	13
3.6	Physical Installation.....	14
3.7	Accessories.....	14
3.8	Main Contactor.....	15
3.9	Circuit Breaker	15
3.10	Power Factor Correction	15
3.11	Short Circuit Protection Devices (SCPD)	15
3.12	IEC Coordination with Short Circuit Protection Devices	16
3.13	UL Coordination with Short Circuit Protection Devices	17
3.14	Fuse Selection for Type 2 Coordination	20
3.15	Specifications	21
3.16	Disposal Instructions	22
4	Installation	23
4.1	Command Source	23
4.2	Basic Setup.....	23
4.3	Inputs	24
4.4	Outputs	26
4.5	Control Voltage	27
4.6	Power Terminations	28
4.7	Typical Installation.....	30
4.8	Quick Setup	31
5	Setup Tools	32
5.1	Command Source	32
5.2	Commissioning.....	32
5.3	Run simulation	32
5.4	Load/Save Settings	33
5.5	USB Save & Load	34
5.6	Network Address.....	35
5.7	Digital I/O State	36
5.8	Analog I/O State.....	36
5.9	Serial Number & Rating	36
5.10	Software Versions.....	37

5.11	Thermistor Reset.....	37
5.12	Reset Thermal Model.....	37
6	Logs	38
6.1	Event Log.....	38
6.2	Counters	38
7	Keypad and Feedback	39
7.1	The Keypad.....	39
7.2	Remote Keypad	40
7.3	Starter status LEDs	40
7.4	Displays	41
8	Operation	42
8.1	Start, Stop and Reset Commands.....	42
8.2	Command Override.....	42
8.3	Emergency Mode	42
8.4	Auxiliary Trip	43
8.5	Typical Control Methods	43
8.6	Soft Start Methods	45
8.7	Stop Methods.....	47
9	Programmable Parameters	48
9.1	Programming Menu.....	48
9.2	Altering Parameter Values	48
9.3	Adjustment Lock.....	48
9.4	Parameter List.....	48
9.5	1 Motor Details	52
9.6	2 Motor Start/Stop	53
9.7	5 Protection Levels.....	55
9.8	6 Protection Action	56
9.9	7 Inputs	59
9.10	8 Relay Outputs	61
9.11	9 Analog Output	63
9.12	10 Display	63
9.13	11 Communications Card.....	66
9.14	12 Pump Input Configuration	69
9.15	13 Flow Protection	71
9.16	14 Pressure Protection.....	72
9.17	15 Pressure Control	73
9.18	16 Depth Protection	74
9.19	17 Thermal Protection.....	74
9.20	20 Advanced.....	75
10	Application Examples.....	76
10.1	Smart Card - Pump Protection	76
10.2	Smart Card - Level Controlled Pump Activation.....	78
11	Troubleshooting.....	79
11.1	Protection Responses	79

11.2	Trip Messages.....	79
11.3	General Faults.....	85

1 About This Manual

**WARNING**

Indicates a hazard that may cause personal injury or death.

**CAUTION**

Indicates a hazard that may damage the equipment or installation.

**NOTE**

Provides helpful information.

1.1 Disclaimer

The examples and diagrams in this manual are included solely for illustrative purposes.

The information contained in this manual is subject to change at any time and without prior notice. In no event will responsibility or liability be accepted for direct, indirect or consequential damages resulting from the use or application of this equipment.

2 Caution Statements

Caution Statements cannot cover every potential cause of equipment damage but can highlight common causes of damage. It is the installer's responsibility to read and understand all instructions in this manual prior to installing, operating or maintaining the equipment, to follow good electrical practice including applying appropriate personal protective equipment and to seek advice before operating this equipment in a manner other than as described in this manual.



NOTE

The WSB soft starter is not user serviceable. The unit should only be serviced by authorised service personnel. Unauthorised tampering with the unit will void the product warranty.

2.1 Electrical shock risk



WARNING – ELECTRICAL SHOCK RISK

The voltages present in the following locations can cause severe electric shock and may be lethal:

- AC supply cables and connections
- Output cables and connections
- Many internal parts of the starter

The AC supply must be disconnected from the starter using an approved isolation device before any cover is removed from the starter or before any servicing work is performed.



SHORT CIRCUIT

The WSB is not short circuit proof. After severe overload or short circuit, the operation of the WSB should be fully tested by an authorised service agent.



GROUNDING AND BRANCH CIRCUIT PROTECTION

It is the responsibility of the user or person installing the WSB to provide proper grounding and branch circuit protection according to local electrical safety codes.



FOR YOUR SAFETY

- § The STOP function of the soft starter does not isolate dangerous voltages from the output of the starter. The soft starter must be disconnected by an approved electrical isolation device before accessing electrical connections.
- § Soft starter protection features apply to motor protection only. It is the user's responsibility to ensure safety of personnel operating machinery.
- § The soft starter is a component designed for integration within an electrical system; it is therefore the responsibility of the system designer/user to ensure the system is safe and designed to comply with relevant local safety standards.

2.2 Unexpected Operation



WARNING – ACCIDENTAL STARTS

In some installations, accidental starts may pose an increased risk to safety of personnel or damage to the machines being driven. In such cases, it is recommended that the power supply to the soft starter is fitted with an isolating switch and a circuit-breaking device (eg power contactor) controllable through an external safety system (eg emergency stop, fault detector).



WARNING – STARTER MAY START OR STOP UNEXPECTEDLY

The WSB will respond to control commands from various sources, and could start or stop unexpectedly. Always disconnect the soft starter from mains voltage before accessing the starter or load.



WARNING – DISCONNECT MAINS BEFORE ACCESSING STARTER OR LOAD

The soft starter has built-in protections which can trip the starter in the event of faults and thus stop the motor. Voltage fluctuations, power cuts and motor jams may also cause the motor to trip.

The motor could restart after the causes of shutdown are rectified, which may be dangerous for personnel. Always disconnect the soft starter from mains voltage before accessing the starter or load.



CAUTION – MECHANICAL DAMAGE FROM UNEXPECTED RESTART

The motor could restart after the causes of shutdown are rectified, which may be dangerous for certain machines or installations. In such cases, it is essential that appropriate arrangements are made against restarting after unscheduled stops of the motor.

2.3 Avertissements à l'attention des clients canadiens



AVERTISSEMENT

L'icône AVERTISSEMENT ci-contre signale les informations concernant des risques pouvant entraîner des blessures graves, voire mortelles. Pour votre sécurité, veuillez consulter les avertissements sur cette page ou demander une copie du présent manuel en français auprès de votre distributeur local.



AVERTISSEMENT – RISQUE DE CHOC ÉLECTRIQUE

Les zones suivantes sont soumises à des tensions pouvant provoquer des risques de chocs électriques graves, voire mortels :

- Raccordement et câbles d'alimentation AC
- Câbles et raccordements de sortie
- De nombreuses pièces internes du démarreur

L'alimentation AC doit être déconnectée du démarreur au moyen d'un dispositif d'isolation agréé avant de retirer des capots ou avant de procéder à des travaux d'entretien.



PAR SÉCURITÉ

- § La fonction STOP du démarreur progressif n'isole pas des tensions dangereuses de la sortie du démarreur. Le démarreur progressif doit être déconnecté par un dispositif d'isolement électrique approprié avant d'accéder aux connexions électriques.
- § Les fonctions de protection du démarreur progressif ne concernent que la protection du moteur. Il relève de la responsabilité de l'utilisateur d'assurer la sécurité des personnes travaillant sur les machines.
- § Le démarreur progressif est un appareil conçu pour s'intégrer dans un système électrique ; il relève donc de la responsabilité du concepteur ou de l'utilisateur de veiller à ce que ce système soit sûr et conçu selon les normes de sécurité locales en vigueur.



AVERTISSEMENT – DÉMARRAGES ACCIDENTELS

Dans certaines installations, des démarrages accidentels peuvent provoquer un risque supplémentaire pour la sécurité des personnes ou endommager les machines contrôlées. Dans de tels cas, il est recommandé de doter l'alimentation du démarreur progressif d'un interrupteur d'isolement et d'un coupe-circuit (par exemple, un disjoncteur) contrôlable à partir d'un système de sécurité externe (par exemple, un arrêt d'urgence, un détecteur de défaut).



AVERTISSEMENT – LE DÉMARREUR PEUT DÉMARRER OU S'ARRÊTER À TOUT MOMENT

Le WSB répond aux commandes de contrôle de différentes origines et peut par conséquent démarrer ou s'arrêter à tout moment. Toujours déconnecter le démarreur de la tension secteur avant d'accéder au démarreur ou à la charge.

**AVERTISSEMENT – DÉCONNECTER L'ALIMENTATION PRINCIPALE AVANT D'ACCÉDER AU DÉMARREUR OU À LA CHARGE**

Le démarreur progressif comporte des protections intégrées qui peuvent déclencher des mises en sécurité dans l'éventualité de défauts et ainsi arrêter le moteur. Des fluctuations de tension, des coupures d'alimentation et des blocages du moteur peuvent produire des mises en sécurité de celui-ci.

Le moteur pourrait redémarrer une fois que les causes de l'arrêt ont été résolues, ce qui pourrait mettre en danger le personnel. Toujours déconnecter le démarreur de la tension secteur avant d'accéder au démarreur ou à la charge.

**AVERTISSEMENT**

Ne pas appliquer la tension du secteur au démarreur tant que tout le câblage n'est pas terminé.

**AVERTISSEMENT**

Toujours appliquer la tension de commande avant (ou en même temps que) la tension secteur.

**AVERTISSEMENT**

Lors du raccordement du WSB en connexion 6 fils, toujours installer un contacteur principal ou un disjoncteur magnéto-thermique à bobine de déclenchement.

3 System Design

3.1 Feature List

Streamlined setup process

- Configuration profiles for common applications
- Built-in metering and inputs/outputs

Easy to understand interface

- Multi-language menus and displays
- Descriptive option names and feedback messages
- Real-time performance graphs

Supports energy efficiency

- IE3 compatible
- 99% energy efficient when running
- Internal bypass
- Soft start technology avoids harmonic distortion

Extensive range of models

- 24 A to 580 A (nominal)
- 200 ~ 525 VAC
- 380 ~ 600 VAC

Versatile starting and stopping options

- Adaptive Control
- Constant Current
- Current Ramp
- Timed voltage ramp soft stop
- Coast To Stop

Customisable protection

- Motor overload
- Excess Start Time
- Undercurrent
- Overcurrent
- Current imbalance
- Input Trip
- Motor thermistor

Extensive input and output options

- Remote control inputs (2 x fixed, 2 x programmable)
- Relay outputs (1 x fixed, 2 x programmable)
- Analog output

Optional features for advanced applications

- Smart cards
- Communication options: DeviceNet, Ethernet/IP, Modbus RTU, Modbus TCP, Profibus, Profinet

3.2 Model Code

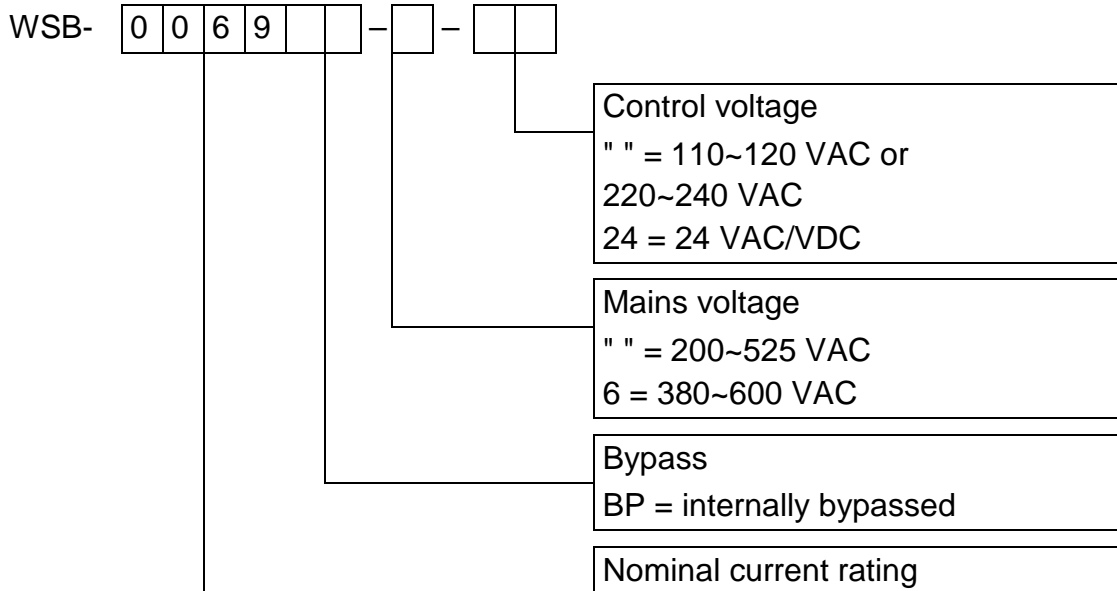

3.3 Model Selection

Starter sizing

The soft starter must be the correct size for the motor and the application.

Select a soft starter that has a current rating at least equal to the motor's full load current (nameplate) rating, at the start duty.

The soft starter's current rating determines the maximum motor size it can be used with. The soft starter's rating depends on the number of starts per hour, the length and current level of the start, and the amount of time the soft starter will be off (not passing current) between starts.

The soft starter's current rating is only valid when used in the conditions specified in the AC53b code - the soft starter may have a higher or lower current rating in different operating conditions.

3.4 Current Ratings

For operating conditions not covered by these ratings charts, download WorldWide Electric's free WORLDStart Select selection application, or contact your local supplier.

IEC ratings

- AC53b format

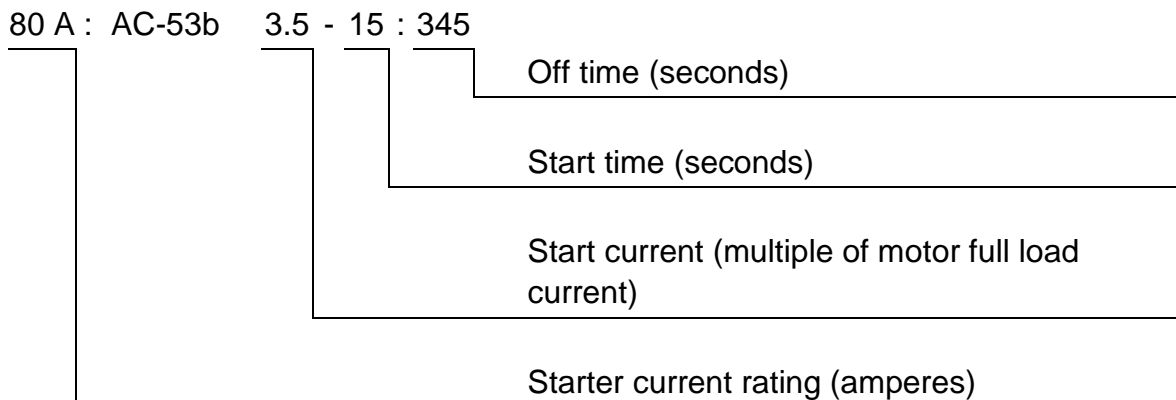

· **Ratings**

All ratings are calculated at altitude of 1000 metres and ambient temperature of 40 °C.

	3.0-10:350	3.5-15:345	4.0-10:350	4.0-20:340	5.0-5:355
WSB-0024BP	24	20	19	16	17
WSB-0042BP	42	34	34	27	32
WSB-0052BP	52	42	39	35	34
	3.0-10:590	3.5-15:585	4.0-10:590	4.0-20:580	5.0-5:595
WSB-0064BP	64	63	60	51	54
WSB-0069BP	69	69	69	62	65
WSB-0105BP	105	86	84	69	77
WSB-0115BP	115	108	105	86	95
WSB-0135BP	135	129	126	103	115
WSB-0184BP	184	144	139	116	127
WSB-0200BP	200	171	165	138	150
WSB-0229BP	229	194	187	157	170
WSB-0250BP	250	244	230	200	202
WSB-0352BP	352	287	277	234	258
WSB-0397BP	397	323	311	263	289
WSB-0410BP	410	410	410	380	400
WSB-0550BP	550	527	506	427	464
WSB-0580BP	580	579	555	470	508

NEMA motor ratings

All ratings are calculated at altitude of 1000 metres and ambient temperature of 50 °C.

	Light 300%, 10 s, 6 starts per hour				Normal 350%, 30 s, 4 starts per hour				Heavy 450%, 30 s, 4 starts per hour			
	A	HP @230 VAC	HP @460 VAC	HP @575 VAC	A	HP @230 VAC	HP @460 VAC	HP @575 VAC	A	HP @230 VAC	HP @460 VAC	HP @575 VAC
WSB-0024BP	24	7.5	15	20	17	5	10	15	14	3	10	10
WSB-0042BP	42	15	30	40	28	10	20	25	22	7.5	15	20
WSB-0052BP	52	15	30	50	35	10	25	30	28	10	20	25
WSB-0064BP	64	20	50	60	52	15	30	40	40	10	25	30
WSB-0069BP	69	25	50	60	59	20	40	50	46	15	30	40
WSB-0105BP	100	30	75	100	77	25	50	60	52	15	40	50
WSB-0115BP	115	40	75	100	81	30	60	75	65	20	50	60
WSB-0135BP	135	50	100	125	99	30	75	100	77	25	60	75
WSB-0184BP	164	60	125	150	124	40	75	100	96	30	60	75
WSB-0200BP	200	75	150	200	131	50	100	125	104	40	75	100
WSB-0229BP	229	75	150	200	156	60	125	150	124	40	100	100
WSB-0250BP	250	100	200	250	195	75	150	200	156	60	125	150
WSB-0352BP	341	125	250	350	240	75	150	200	180	60	150	150
WSB-0397BP	389	150	300	400	261	100	200	250	203	75	150	200
WSB-0410BP	410	150	300	450	377	150	300	350	302	100	250	300
WSB-0550BP	550	200	450	500	414	150	350	450	321	125	250	300
WSB-0580BP	580	200	500	500	477	200	400	500	361	150	300	350

3.5 Dimensions and Weights

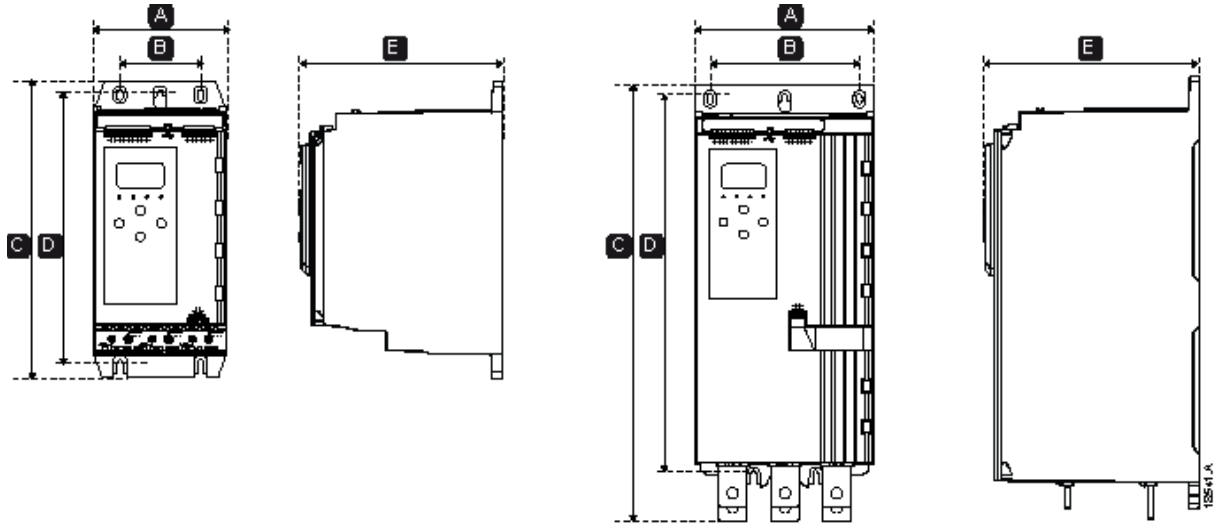

	Width mm (inch)		Height mm (inch)		Depth mm (inch)	Weight kg (lb)
	A	B	C	D	E	
WSB-0024BP	152 (6.0)	92 (3.6)	336 (13.2)	307 (12.1)	231 (9.1)	4.8
WSB-0042BP						(10.7)
WSB-0052BP						4.9
WSB-0064BP						(10.9)
WSB-0069BP						
WSB-0105BP						5.5
WSB-0115BP						(12.1)
WSB-0135BP						
WSB-0184BP	216 (8.5)	180 (7.1)	495 (19.5)	450 (17.7)	243 (9.6)	12.7
WSB-0200BP						(28.0)
WSB-0229BP						
WSB-0250BP						
WSB-0352BP			15.5			
WSB-0397BP			(34.2)			
WSB-0410BP			19.0			
WSB-0550BP			(41.9)			
WSB-0580BP						

3.6 Physical Installation

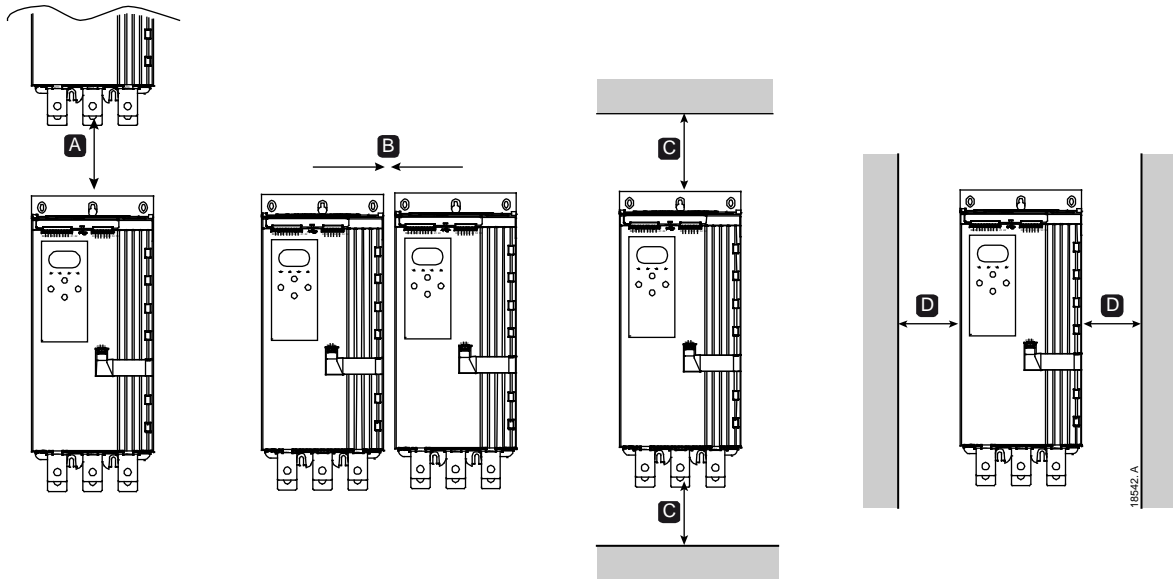

Between starters		Solid surfaces	
A	B	C	D
> 100 mm (3.9 inch)	> 10 mm (0.4 inch)	> 100 mm (3.9 inch)	> 10 mm (0.4 inch)

3.7 Accessories

Expansion Cards

The WSB offers expansion cards for users requiring additional inputs and outputs or advanced functionality. Each WSB can support a maximum of one expansion card.

- **Smart Card**

The smart card has been designed to support integration with pumping applications and provides the following additional inputs and outputs:

- 3 x digital inputs
- 3 x 4-20 mA transducer inputs
- 1 x RTD input
- 1 x USB-B port
- Remote keypad connector

- **Communication Expansion Cards**

WSB soft starters support network communication via easy-to-install communications expansion cards. Each communications card includes a remote keypad connector port.

Available protocols:

DeviceNet, Ethernet/IP, Modbus RTU, Modbus TCP, Profibus, Profinet.

Remote Keypad

WSB starters can be used with a remote keypad, mounted up to 3 metres away from the starter. Each expansion card includes a keypad connection port, or a dedicated keypad connector card is available.

Finger Guard Kit

Finger guards may be specified for personnel safety. Finger guards fit over the soft starter terminals to prevent accidental contact with live terminals. Finger guards provide IP20 protection when used with cable of diameter 22 mm or greater.

Finger guards are compatible with models WSB-0184BP ~ WSB-0580BP.

WORLDStart Visual Starter Management Software

WORLDStart Visual PC software can provide real-time or offline management of all WorldWide Electric soft starters.

- For real-time management in a network of up to 254 starters, WORLDStart Visual must connect to the WSB via a Modbus TCP or Modbus RTU card. WORLDStart Visual can monitor, control and program the starter across the network.
- WORLDStart Visual can be used to program the WSB via the USB port on the pumping smart card.
- For offline management, a configuration file generated in WORLDStart Visual can be loaded into the starter via the USB port.

3.8 Main Contactor

A main contactor is recommended to protect the soft starter from voltage disturbances on the network, while stopped. Select a contactor with an AC3 rating greater than or equal to the full load current rating of the connected motor.

Use the main contactor output (33, 34) to control the contactor.

3.9 Circuit Breaker

A shunt trip circuit breaker may be used instead of a main contactor to isolate the motor circuit in the event of a soft starter trip. The shunt trip mechanism must be powered from the supply side of the circuit breaker or from a separate control supply.

3.10 Power Factor Correction

If power factor correction is used, a dedicated contactor should be used to switch in the capacitors.

To use the WSB to control power factor correction, connect the PFC contactor to a programmable relay set to Run. When the motor reaches full speed, the relay will close and power factor correction will be switched in.



CAUTION

Power factor correction capacitors must be connected to the input side of the soft starter. Connecting power factor correction capacitors to the output side will damage the soft starter.

3.11 Short Circuit Protection Devices (SCPD)

Fuses may be installed to protect the soft starter or the installation.

Type 1 Coordination

Type 1 coordination requires that, in the event of a short circuit on the output side of a soft starter, the fault must be cleared without risk of injury to personnel. There is no requirement that the soft starter must remain operational after the fault.

HRC fuses (such as Ferraz/Mersen AJT fuses) can be used for Type 1 coordination according to IEC 60947-4-2 standard.

Type 2 Coordination

Type 2 coordination requires that in the event of a short circuit on the output side of a soft starter, the fault must be cleared without risk of injury to personnel or damage to the soft starter.

Semiconductor fuses for Type 2 circuit protection are additional to HRC fuses or MCCBs that form part of the motor branch circuit protection.



CAUTION

Integral solid state short circuit protection does not provide branch circuit protection. Branch circuit protection must be provided in accordance with the National Electrical Code and any additional local codes.

3.12 IEC Coordination with Short Circuit Protection Devices

These fuses were selected based on start current of 300% FLC for 10 seconds.

	Nominal Rating (A)	SCR I ² T (A ² S)	Type 1 coordination 480 VAC, 65 kA Bussmann NH fuse links	Type 2 coordination 600 VAC, 65 kA Bussmann DIN 43 653
WSB-0024BP	24	1150	40NHG000B	170M3010
WSB-0042BP	42	7200	63NHG000B	170M3013
WSB-0052BP	52		80NHG000B	
WSB-0064BP	64	15000	100NHG000B	170M3014
WSB-0069BP	69			
WSB-0105BP	105	80000	160NHG00B	170M3015
WSB-0115BP	115			
WSB-0135BP	135	125000		170M3016
WSB-0184BP	184	320000	250NHG2B	170M3020
WSB-0200BP	200			
WSB-0229BP	229		315NHG2B	
WSB-0250BP	250			170M3021
WSB-0352BP	352	202000	355NHG2B	170M6009
WSB-0397BP	397		400NHG2B	
WSB-0410BP	410	320000	425NHG2B	170M6010
WSB-0550BP	550	781000	630NHG3B	170M6012
WSB-0580BP	580			

3.13 UL Coordination with Short Circuit Protection Devices

Standard Fault Short Circuit Current Ratings

Suitable for use on a circuit capable of delivering not more than the stated level of amperes (symmetrical rms, refer ##1 in table), 600 VAC maximum.

· **Maximum fuse rating (A) – Standard fault short circuit current**

Model	Nominal Rating (A)	3 cycle short cct rating @600 VAC ##1 †
WSB-0024BP	24	5 kA
WSB-0042BP	42	
WSB-0052BP	52	10 kA
WSB-0064BP	64	
WSB-0069BP	69	
WSB-0105BP	105	
WSB-0115BP	120	
WSB-0135BP	135	
WSB-0184BP	184	18 kA
WSB-0200BP	225	
WSB-0229BP	229	
WSB-0250BP	250	
WSB-0352BP	352	
WSB-0397BP	397	
WSB-0410BP	410	30 kA
WSB-0550BP	550	
WSB-0580BP	580	

† Suitable for use in a circuit with the prospective current noted, when protected by any Listed fuses or Listed circuit breakers sized according to the NEC.

High Fault Short Circuit Current Ratings

- Maximum fuse rating (A) – High fault short circuit current

Suitable for use on a circuit capable of delivering not more than 65,000 rms symmetrical amperes, 480 VAC maximum, when protected by fuses of the stated class and rating (refer ##2 and ##3 in table).

Model	Nominal Rating (A)	Short Circuit Rating @ 480 VAC max.	Listed fuse rating (A) ##3	Fuse class ##2
WSB-0024BP	24	65 kA	30	Any (J, T, K-1, RK1, RK5)
WSB-0042BP	42		50	
WSB-0052BP	52		60	
WSB-0064BP	64		80	
WSB-0069BP	69		80	
WSB-0105BP	105		125	J, T, K-1, RK1
WSB-0115BP	120		125	
WSB-0135BP	135		150	
WSB-0184BP	184		200	J, T
WSB-0200BP	225		225	
WSB-0229BP	229		250	
WSB-0250BP	250		300	
WSB-0352BP	352		400	Any (J, T, K-1, RK1, RK5)
WSB-0397BP	397		450	
WSB-0410BP	410		450	
WSB-0550BP	550		600	
WSB-0580BP	580		600	

• **Circuit breakers – High fault short circuit current**

Suitable for use on a circuit capable of delivering not more than 65,000 rms symmetrical amperes, 480 VAC maximum, when protected by circuit breaker models noted in ##4, ##5 or ##6.

Model	Nominal Rating (A)	Breaker 1: Eaton (rating, A) ##4	Breaker 2: GE (rating, A) ##5	Breaker 3: LS (rating, A) ¹ ##6
WSB-0024BP	24	HFD3030 (30 A)	SELA36AT0060 (60 A)	UTS150H-xxU-040 (40 A)
WSB-0042BP	42	HFD3050 (50 A)		UTS150H-xxU-050 (50 A)
WSB-0052BP	52	HFD3060 (60 A)		UTS150H-xxU-060 (60 A)
WSB-0064BP	64	HFD3100 (100 A)	SELA36AT0150 (150 A)	UTS150H-xxU-100 (100 A)
WSB-0069BP	69			
WSB-0105BP	105	HFD3125 (125 A)		UTS150H-xxU-125 (125 A)
WSB-0115BP	120			
WSB-0135BP	135	HFD3150 (150 A)		UTS150H-xxU-150 (150 A)
WSB-0184BP	184	HFD3250 (250 A)	SELA36AT0250 (250 A)	UTS150H-xxU-250 (250 A)
WSB-0200BP	225			
WSB-0229BP	229			
WSB-0250BP	250	HFD3300 (300 A)	SELA36AT0400 (400 A)	UTS150H-xxU-300 (300 A)
WSB-0352BP	352	HFD3400 (400 A)	SELA36AT0600 (600 A)	UTS150H-xxU-400 (400 A)
WSB-0397BP	397			
WSB-0410BP	410	HFD3600 (600 A)		UTS150H-xxU-600 (600 A)
WSB-0550BP	550			UTS150H-xxU-800 (800 A)
WSB-0580BP	580			UTS150H-NG0-800

¹ For LS breakers, xx represents FM, FT or AT.

3.14 Fuse Selection for Type 2 Coordination

Type 2 coordination is achieved by using semiconductor fuses. These fuses must be able to carry motor start current and have a total clearing I^2t less than the I^2t of the soft starter SCRs.

When selecting semiconductor fuses for WSB, use the I^2t values in the table.

For further information on selecting semiconductor fuses, contact your local distributor or download the fuse selection application note from www.worldwideelectric.net.

I²t values for Type 2 coordination

Model	SCR I^2t (A ² s)
WSB-0024BP	1150
WSB-0042BP	7200
WSB-0052BP	
WSB-0064BP	15000
WSB-0069BP	
WSB-0105BP	80000
WSB-0115BP	
WSB-0135BP	125000
WSB-0184BP	
WSB-0200BP	320000
WSB-0229BP	
WSB-0250BP	
WSB-0352BP	
WSB-0397BP	202000
WSB-0410BP	
WSB-0550BP	320000
WSB-0580BP	
	781000

3.15 Specifications

Supply

Mains voltage (L1, L2, L3)

WSB-xxxxBP 200~525 VAC ($\pm 10\%$)

WSB-xxxxBP-6 380~600 VAC ($\pm 10\%$)

Control voltage (A1, A2, A3)

WSB-xxxxBP-(6) (A1, A2) 110~120 VAC (+10%/-15%), 600 mA

WSB-xxxxBP-(6) (A2, A3) 220~240 VAC (+10%/-15%), 600 mA

WSB-xxxxBP-(6)-24 (A1, A2) 24 VAC/VDC ($\pm 20\%$), 2.8 A

Mains frequency 50 Hz ~ 60 Hz (± 5 Hz)

Rated insulation voltage to earth 600 VAC

Rated impulse withstand voltage 6 kV

Form designation .. Bypassed or continuous, semiconductor motor starter form 1

Short circuit capability

Coordination with semiconductor fuses..... Type 2

Coordination with HRC fuses Type 1

Electromagnetic capability (compliant with EU Directive 2014/35/EU)

EMC Immunity..... IEC 60947-4-2

EMC Emissions IEC 60947-4-2 Class B

Inputs

Input rating Active 24 VDC, 8 mA approx

Motor thermistor (B4, B5) Trip >3.6 kW, reset <1.6 kW

Outputs

Relay outputs 10A @ 250 VAC resistive, 5A @ 250 VAC AC15 pf 0.3

Main contactor (33, 34) Normally Open

Relay output A (41, 42, 44) Changeover

Relay output B (53, 54) Normally Open

Analog output (21, 22)

Maximum load 600 W (12 VDC @ 20 mA)

Accuracy $\pm 5\%$

Environmental

Operating temperature -10 °C to 60 °C, above 40 °C with derating

Storage temperature -25 °C to + 60 °C

Operating Altitude 0 - 1000 m, above 1000 m with derating

Humidity 5% to 95% Relative Humidity

Pollution degree Pollution Degree 3

Vibration IEC 60068-2-6

Protection

WSB-0024BP ~ WSB-0135BP IP20

WSB-0184BP ~ WSB-0580BP IP00

Heat dissipation

During Start 4.5 watts per ampere

During Run

WSB-0024BP ~ WSB-0052BP	≤ 35 watts approx
WSB-0064BP ~ WSB-0135BP	≤ 50 watts approx
WSB-0184BP ~ WSB-0250BP	≤ 120 watts approx
WSB-0352BP ~ WSB-0580BP	≤ 140 watts approx

Motor Overload Protection

Default: The default settings of parameters 1C, 1D and 1E provide Motor Overload Protection: Class 10, Trip Current 105% of FLA (full load amperage) or equivalent.

Certification

CE	EN 60947-4-2
C-UL	C22.2 N° 60947-4-2
UL	UL 60947-4-2

Operational life (internal bypass contacts)

..... 100 000 operations

3.16 Disposal Instructions

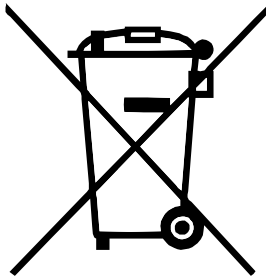

Equipment containing electrical components may not be disposed of together with domestic waste.

It must be collected separately as electrical and electronic waste according to local and currently valid legislation.

4 Installation

**WARNING**

Do not apply mains voltage to the starter until all wiring is complete.

**WARNING**

Always apply control voltage before (or with) mains voltage.

4.1 Command Source

The WSB can be started and stopped via the digital inputs, remote keypad, communication network or smart card. The command source can be set via the Setup Tools, or using parameter 1A *Command Source*.

4.2 Basic Setup

Setup Procedure Overview

1. Mount the soft starter (refer to *Physical Installation* on page 14 for details).
2. Connect control wiring (refer to *Input Terminals* on page 24 for details).
3. Apply control voltage to the starter.
4. Configure your application:
 1. Press **MENU** to open the Menu.
 2. Press **ENTER/MENU** to open the Quick Setup menu.
 3. Scroll through the list to find your application, then press **ENTER/MENU** to begin the configuration process (refer to *Quick Setup* on page 31 for details).
5. If your application is not listed in Quick Setup:
 1. Press **EXIT/RESET** to return to the Menu.
 2. Use ▼ to scroll to Main Menu and press **ENTER/MENU**.
 3. Scroll to Motor Details and press **ENTER/MENU**, then press **ENTER/MENU** again to edit parameter 1B *Motor Full Load Current*.
 4. Set parameter 1B to match the motor's full load current (FLC).
 5. Press **ENTER/MENU** to save the setting.
6. Close the Menu by pressing **EXIT/RESET** repeatedly.
7. (Optional) Use the built-in simulation tools to check that the control wiring is connected correctly (refer to *Run simulation* on page 32).
8. Power off the soft starter.
9. Connect the motor cables to starter output terminals 2/T1, 4/T2, 6/T3.
10. Connect mains supply cables to starter input terminals 1/L1, 3/L2, 5/L3 (refer to *Power Terminations* on page 28).

The soft starter is now ready to control the motor.

4.3 Inputs



CAUTION

The control inputs are powered by the soft starter. Do not apply external voltage to the control input terminals.



NOTE

Cables to the control inputs must be segregated from mains voltage and motor cabling.

Input Terminals

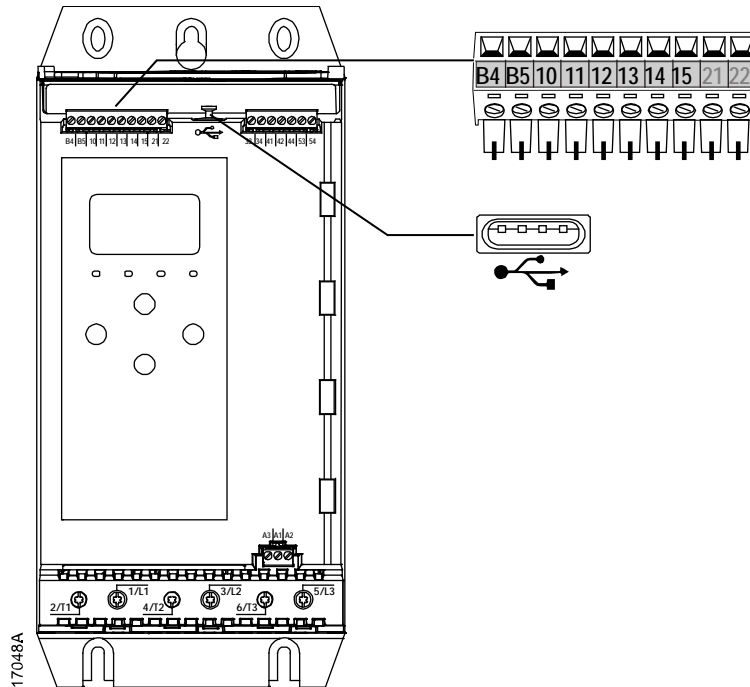

B4, B5	Motor thermistor input
10, 11	Reset input
11, 12	Start/stop input
13, 14	Programmable input A (default = Input Trip (N/O))
13, 15	Programmable input B (default = Input Trip (N/O))
	USB port

Motor Thermistor

Motor thermistors can be connected directly to the WSB. The soft starter will trip when the resistance of the thermistor circuit exceeds approximately 3.6 kW or falls below 20 W.

The thermistors must be wired in series. The thermistor circuit should be run in screened cable and must be electrically isolated from earth and all other power and control circuits.



NOTE

The thermistor input is disabled by default, but activates automatically when a thermistor is detected. If thermistors have previously been connected to the WSB but are no longer required, use the Thermistor Reset function to disable the thermistor. Thermistor Reset is accessed via the Setup Tools.

Start/Stop

The WSB requires two-wire control.

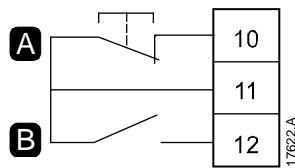

A	Reset
B	Start/Stop



NOTE

The WSB will only accept commands from the control inputs if parameter 1A *Command Source* is set to Digital Input.

Reset/Starter Disable

The reset input (10, 11) is normally closed by default. The WSB will not perform a start if the reset input is open. The display will show "Not Ready".

If the reset input opens while the WSB is running, the starter will remove power and allow the motor to coast to stop.



NOTE

The reset input can be configured for normally closed operation. Use parameter 7I *Reset/Enable Logic*.

Programmable Inputs

The programmable inputs (13, 14 and 13, 15) allow external equipment to control the starter.

The operation of the programmable inputs is controlled by parameters 7A ~ 7H.

USB Port

The USB port can be used to upload a configuration file, or download parameter settings and event log information from the starter. Refer to *USB Save & Load* on page 34 for details.

4.4 Outputs

Output Terminals

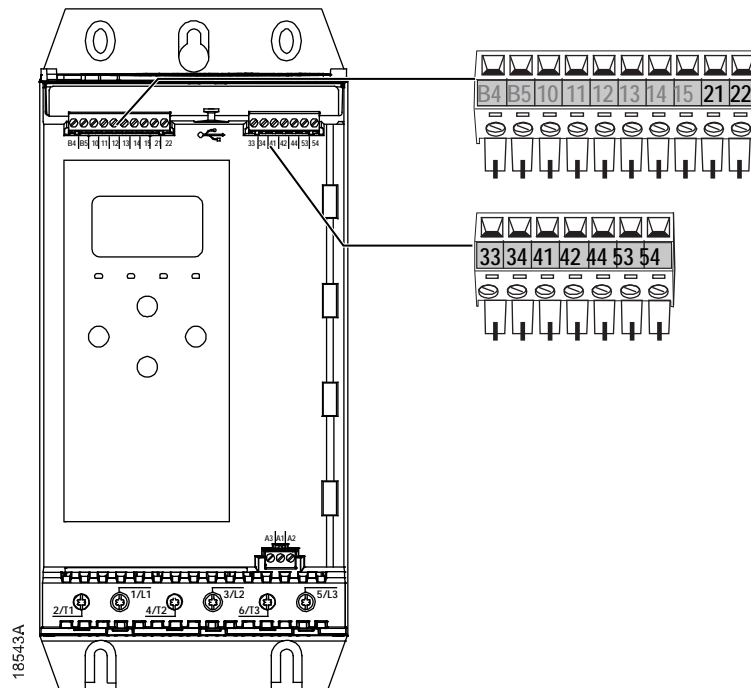

21, 22	Analog output
33, 34	Main contactor output
41, 42, 44	Relay output A (default = Run)
53, 54	Relay output B (default = Run)

Analog Output

The WSB has an analog output, which can be connected to associated equipment to monitor motor performance.

The operation of the analog output is controlled by parameters 9A ~ 9D.

Main Contactor Output

The main contactor output (33, 34) closes as soon as the soft starter receives a start command and remains closed while the soft starter is controlling the motor (until the motor starts a coast to stop, or until the end of a soft stop). The main contactor output will also open if the soft starter trips.



CAUTION

Some electronic contactor coils are not suitable for direct switching with PCB mount relays. Consult the contactor manufacturer/supplier to confirm suitability.

Programmable Outputs

The programmable outputs (41, 42, 44 and 53, 54) can report the status of the starter, or can be used to control associated equipment.

The operation of the programmable outputs is controlled by parameters 8A ~ 8F.

4.5 Control Voltage

Control Voltage Terminals

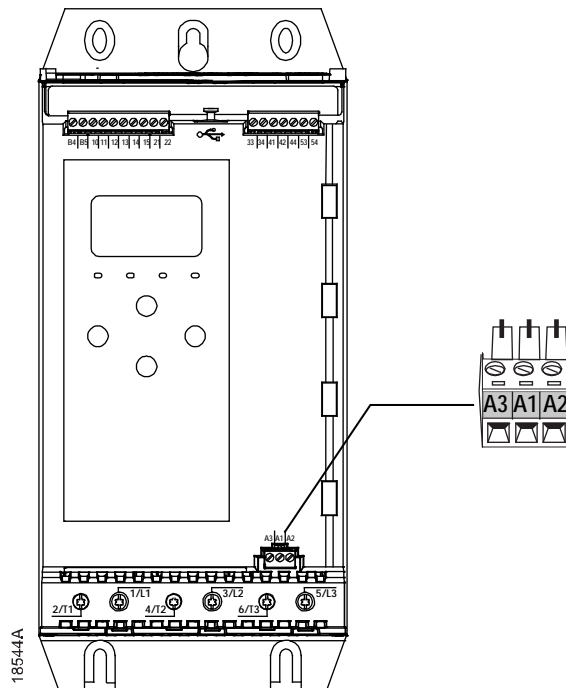

Connect the control supply according to the supply voltage being used.

- WSx-xxxxBP-(6) (110~120 VAC): A1, A2
- WSx-xxxxBP-(6) (220~240 VAC): A2, A3
- WSx-xxxxBP-(6)-24 (24 VAC/VDC): A1, A2

UL Compliant Installation

For models WSB-0184BP to WSB-0580BP to be UL compliant, supplementary or branch overcurrent protection must be used on the control circuit supply (A1, A2, A3), in accordance with the electrical code applicable at the installation location.

4.6 Power Terminations

The power input and output terminals for WSB are at the bottom of the unit.

- Models WSB-0024BP~WSB-0135BP use cage clamps.
- Models WSB-0184BP~WSB-0580BP use busbars.



NOTE

Some units use aluminium busbars. When connecting power terminations, we recommend cleaning the surface contact area thoroughly (using an emery or stainless steel brush) and using an appropriate jointing compound to prevent corrosion.

Use only copper stranded or solid conductors, rated for 75 °C or higher.

WSB-0024BP~WSB-0135BP	
<p>Cable size: 6-70 mm² (AWG 10-2/0) Torque: 4 Nm (2.9 ft-lb) 14 mm (0.55 inch)</p>	<p>Torx T20 x 150 Flat 7 mm x 150</p>
WSB-0184BP~WSB-0250BP	WSB-0352BP~WSB-0580BP
<p>19 Nm (14.0 ft-lb)</p>	<p>66 Nm (49.0 ft-lb)</p>



NOTE

If the installation requires large diameter cables, it is possible to complete each termination with two smaller cables, one on each side of the busbar.

UL Compliant Installation

For models WSx-0184BP to WSx-0580BP to be UL compliant, you must use the recommended pressure terminal/connector.

Model	Recommended lugs part No.
WSB-0184BP	OPHD 185-10
WSB-0200BP	
WSB-0229BP	
WSB-0250BP	
WSB-0352BP	OPHD 150-12
WSB-0397BP	
WSB-0410BP	
WSB-0550BP	OPHD 240-12
WSB-0580BP	

Motor Connection

WSB soft starters must be connected to the motor in-line (also called three-wire connection).

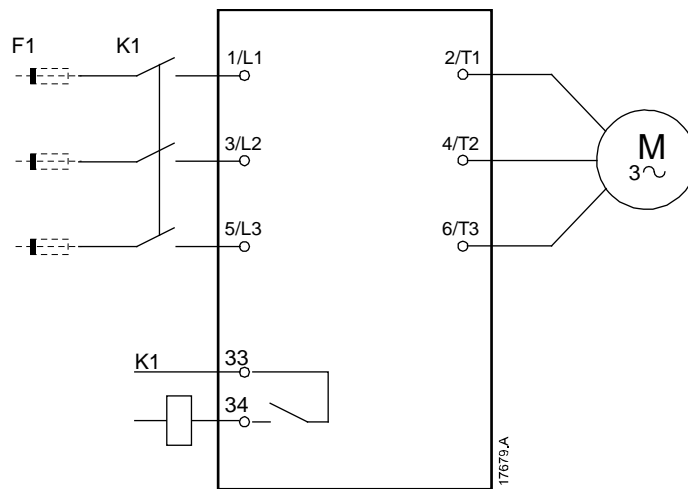

K1	Main contactor (strongly recommended)
F1	Fuses or circuit breaker (optional)
33, 34	Main contactor output

4.7 Typical Installation

The WSB is installed with a main contactor (AC3 rated). Control voltage must be supplied from the input side of the contactor.

The main contactor is controlled by the main contactor output (33, 34).

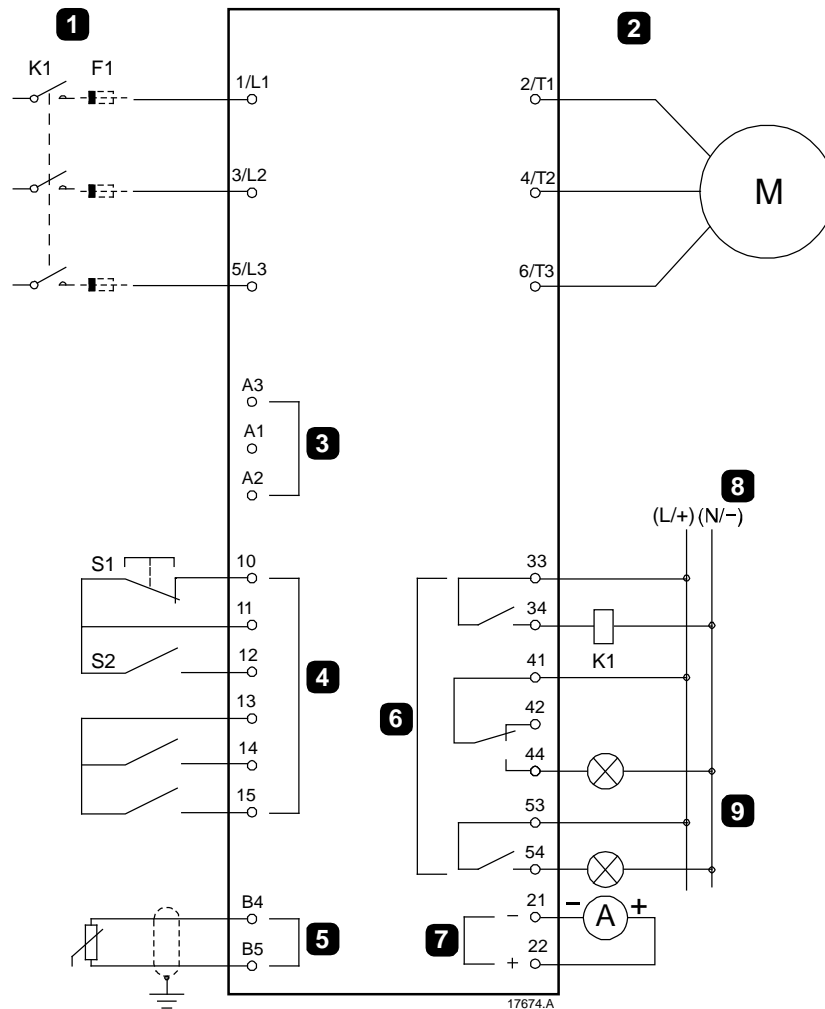

1	Three-phase supply
2	Motor
3	Control voltage (soft starter)
4	Digital inputs
5	Motor thermistor input
6	Relay outputs
7	Analog output
8	Control voltage (external equipment)
9	Pilot lamps

K1	Main contactor
F1	Semiconductor fuses (optional)
10, 11 (S1)	Reset
11, 12 (S2)	Start/Stop
13, 14	Programmable input A (default = Input Trip (N/O))
13, 15	Programmable input B (default = Input Trip (N/O))
B4, B5	Motor thermistor input
33, 34	Main contactor output
41, 42, 44	Relay output A (default = Run)
53, 54	Relay output B (default = Trip)
21, 22	Analog output

4.8 Quick Setup

The Quick Setup Menu makes it easy to configure the WSB for common applications. The WSB guides you through the most common installation parameters, and suggests a typical setting for the application. You can adjust each parameter to suit your exact requirements.

All other parameters remain at default values. To change other parameter values or review the default settings, use the menu (refer to Parameter List for details).

Always set parameter 1B *Motor Full Load Current* to match the motor's nameplate full load current.

Application	Start Mode	Start Ramp Time (seconds)	Initial Current (%)	Current Limit (%)	Adaptive Start Profile	Stop Mode	Stop Time (seconds)	Adaptive Stop Profile
Pump Centrifugal	Adaptive Control	10	200	500	Const. accel.	Adaptive Control	15	Const. decel.
Pump bore	Adaptive Control	3	200	500	Const. accel.	Adaptive Control	3	Const. decel.
Pump Hydraulic	Constant Current	2	200	350	n/a	Coast To Stop	n/a	n/a
Fan Damped	Constant Current	2	200	350	n/a	Coast To Stop	n/a	n/a
Fan Undamped	Constant Current	2	200	450	n/a	Coast To Stop	n/a	n/a
Compressor Screw	Constant Current	2	200	400	n/a	Coast To Stop	n/a	n/a
Compressor Recip	Constant Current	2	200	450	n/a	Coast To Stop	n/a	n/a
Conveyor	Constant Current	5	200	450	n/a	Coast To Stop	n/a	n/a
Bow thruster	Constant Current	5	100	400	n/a	Coast To Stop	n/a	n/a
Bandsaw	Constant Current	2	200	450	n/a	Coast To Stop	n/a	n/a



NOTE

The Adaptive Start and Stop Profile settings only apply when using Adaptive Control. The settings are ignored for all other start and stop modes.

5 Setup Tools

Setup Tools includes options to load or save parameters to a backup file, set the starter's network address, check the status of the inputs and outputs, reset the thermal models or test operation using the Run Simulation.

To access the Setup Tools, press **MENU** to open the Menu then select Setup Tools.

5.1 Command Source

The WSB can be started and stopped via the digital inputs, remote keypad, communication network or smart card. The command source can be set via the Setup Tools, or using parameter 1A *Command Source*.

If the remote keypad is installed, the **LCL/RMT** button provides shortcut access to the Command Source function in Setup Tools.

5.2 Commissioning

Commissioning lets the starter be started and stopped via the local keypad. Use the **▲** and **▼** buttons to select a function, then press **ENTER/MENU** to send the selected command to the starter. The available functions are:

- Quick stop (coast to stop)/Reset
- Start
- Stop

5.3 Run simulation

The run simulation simulates a motor starting, running and stopping to confirm that the soft starter and associated equipment have been installed correctly.



NOTE

The soft starter must be disconnected from mains voltage.

The simulation is only available when the soft starter is in Ready state.

To use the run simulation:

1. Press **MENU** to open the menu then select Setup Tools.
2. Scroll to Run Simulation and press **ENTER/MENU**.

Run Simulation
 Ready
 Apply Start Signal

3. Apply a start command from the selected command source. The WSB simulates its pre-start checks and closes the main contactor relay. The Run LED flashes.

Run Simulation
 Pre-Start Checks
 MENU to Continue



NOTE

If mains voltage is connected, an error message is shown.

Run Simulation
ATTENTION!
 Remove Mains Volts
 MENU to Continue

4. Press **ENTER/MENU**. The WSB simulates starting. The Run LED flashes.

```
Run Simulation
Starting X:XXs
MENU to Continue
```

5. Press **ENTER/MENU**. The WSB simulates running.

```
Run Simulation
Running
Apply Stop Signal
```

6. Apply a stop command from the selected command source. The WSB simulates stopping. The Run LED flashes.

```
Run Simulation
Stopping X:XXs
MENU to Continue
```

7. Press **ENTER/MENU**. The Ready LED flashes and the main contactor relay opens.

```
Run Simulation
Stopped
MENU to Continue
```

8. Press **ENTER/MENU**. The WSB activates then deactivates each programmable output.

```
Run Simulation
Prog Relay A
On
MENU to Continue
```

9. Press **ENTER/MENU** to return to the Setup Tools.

5.4 Load/Save Settings

Load/Save Settings allows users to:

- Reset the WSB's parameters to default values
- Load parameter settings from an internal file
- Save the current parameter settings to an internal file

The internal file contains default values until a user file is saved.

To load or save parameter settings:

1. Press **MENU** to open the menu then select Setup Tools.
2. Scroll to Load/Save Settings and press the **ENTER/MENU** button.
3. Scroll to the required function and press the **ENTER/MENU** button.
4. At the confirmation prompt, select YES to confirm or NO to cancel, then press **ENTER/MENU** to proceed.

```
Load/Save Settings
Load Defaults
Load User Set
Save User Set
```

```
Load Defaults
No
Yes
```

When the action has been completed, the screen will briefly display a confirmation message, then return to the previous menu level.

5.5 USB Save & Load

The USB Save & Load menu lets you:

- Save parameter settings and all event log entries to an external file (CSV format)
- Save parameter settings to an external file (proprietary format)
- Load parameter settings from a previously saved external file
- Load custom messages to display on the keypad when a programmable input is active



NOTE

WSB supports FAT32 file systems. WSB USB functions are not compatible with NTFS file systems.

Save & Load Procedure

1. Connect the external drive to the USB port.
2. Press **MENU** to open the menu then select Setup Tools.
3. Scroll to USB Save & Load and press the **ENTER/MENU** button.
4. Scroll to the required function and press the **ENTER/MENU** button.
5. At the confirmation prompt, select YES to confirm or NO to cancel, then press **ENTER/MENU** to proceed.

When the action has been completed, the screen will briefly display a confirmation message, then return to the previous menu level.

```
USB Save & Load
Save Params and Logs
Save Master Params
Load Master Params
```

```
Save Params and Logs
No
Yes
```

File Locations and Formats

Save Parameters and Logs: The WSB will create a directory at the top level of the USB drive, named with the soft starter's serial number. The event log and parameter settings are saved as individual CSV files, and the soft starter's software and system information are saved to a text file.

Save Master Parameters: The WSB will create a file called `Master_Parameters.par`, in the top level of the USB drive.

Load Master Parameters: The WSB will load the file `Master_Parameters.par` from the top level of the USB drive. This file can be created or edited using `WORLDStart Visual` management software.

Load Custom Message: The WSB will load the files `Custom_Message_A.txt` and `Custom_Message_B.txt` from the top level of the USB drive.

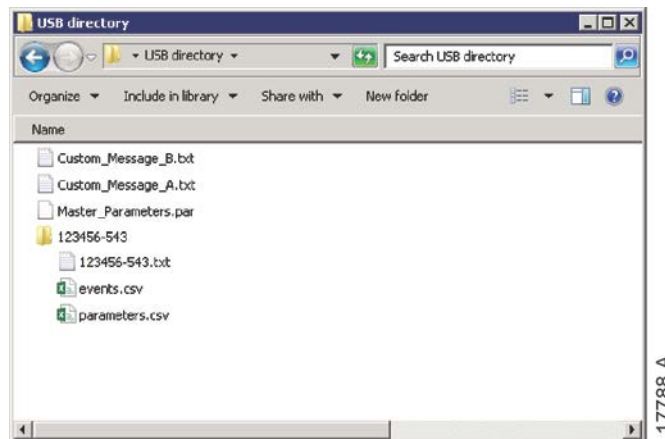

5.6 Network Address

To use the WSB on an Ethernet network, separate addresses must be configured for:

- IP Address
- Gateway Address
- Subnet Mask

To set the network addresses:

1. Press **MENU** to open the menu then select Setup Tools.
2. Scroll to Network Address and press the **ENTER/MENU** button.
3. Scroll to the required function and press the **ENTER/MENU** button.
4. The first digit of the address will be highlighted.
5. Use **EXIT/RESET** and **ENTER/MENU** to select which digit to alter. Use **▲** and **▼** to change the value.
6. Press **ENTER/MENU** after the last digit to save the setting.

```
Set IP Address
192.168.000.002
```

When the action has been completed, the screen will briefly display a confirmation message, then return to the previous menu level.



NOTE

The network address can also be set using parameters 11H~11S.



NOTE

To configure the WSB for use with other communication protocols, use parameters 11A~11G.

5.7 Digital I/O State

The top line of the screen shows the start/stop, reset and programmable inputs.

The bottom line of the screen shows the fixed Main Contactor output, then programmable outputs A and B.

```

Digital I/O State
Inputs:  00000000
Outputs: 00000000
    
```

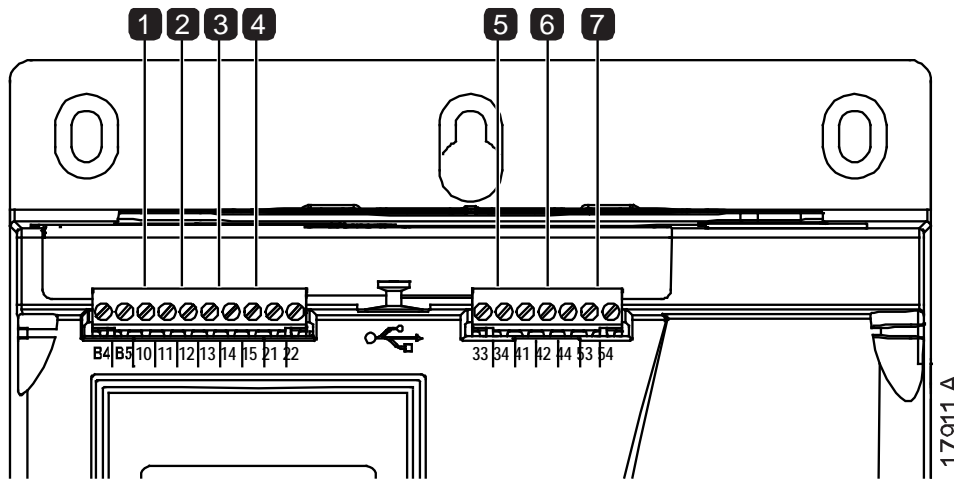

1	10, 11: Reset input
2	11, 12: Start/stop input
3	13, 14: Programmable input A
4	13, 15: Programmable input B

5	33, 34: Main contactor output
6	41, 42, 44: Relay output A
7	53, 54: Relay output B

5.8 Analog I/O State

The top line of the screen shows the state of the motor thermistor input.

The bottom line of the screen shows the value of the analog output.

```

Analog I/O State
Thermistor: 0
4-20mA Output: 04.0 mA
    
```

Thermistor input:

- S = Short
- H = Hot
- C = Cold
- O = Open

5.9 Serial Number & Rating

The top line of the screen shows the product name.

The middle line shows the unit's serial number.

The bottom line of the screen shows the model number.

```

Serial Number & Rating
WSB
123456-123
0069-V5-S1-C1
    
```

5.10 Software Versions

The software versions screen reports the version of each software component in the starter:

- user interface
- motor control
- remote keypad (if connected)
- parameter list
- bootloader
- expansion card (if fitted)



NOTE

Updated software, including alternative languages, can be loaded into the starter via the USB port if required. Contact your local supplier for further information.

5.11 Thermistor Reset

The thermistor input is disabled by default, but activates automatically when a thermistor is detected. If thermistors have previously been connected to the WSB but are no longer required, use the Thermistor Reset function to disable the thermistor.

5.12 Reset Thermal Model

The WSB's advanced thermal modelling software constantly monitors the motor's performance. This allows the WSB to calculate the motor's temperature and ability to start successfully at any time.

The thermal model can be reset if required.



CAUTION

Resetting the motor thermal model will compromise thermal model protection and may compromise motor life. Only reset the thermal model in an emergency.

6 Logs

The Logs Menu provides information on events, trips and starter performance.

To access the Logs Menu on the local keypad, press **MENU** to open the Menu then select Logs. On the remote keypad, press **LOGS**.

6.1 Event Log

The Event Log stores details of the starter's most recent trips, warnings, and operations (including starts, stops and configuration changes).

Event 1 is the most recent and event 384 is the oldest stored event.

**NOTE**

Events in the WSB event log are timestamped based on time elapsed since control power was last applied. The timestamp resets to zero when control power is cycled.

**NOTE**

The event log can be exported to an external file for analysis away from the starter. Refer to *USB Save & Load* on page 34 for details.

6.2 Counters

The counters store statistics on the starter's operation:

- Hours run (lifetime and since counter last reset)
- Number of starts (lifetime and since counter last reset)
- Number of times the thermal model has been reset

To view the counters:

1. Open the Logs Menu.
2. Scroll to counters and press **ENTER/MENU**.
3. Use the **▲** and **▼** buttons to scroll through the counters. Press **ENTER/MENU** to view details.
4. To reset a counter, press **ENTER/MENU** then use the **▲** and **▼** buttons to select Reset/Do Not Reset. Press **ENTER** to confirm the action.

To close the counter and return to the Logs Menu, press **ENTER/MENU**.

7 Keypad and Feedback

7.1 The Keypad

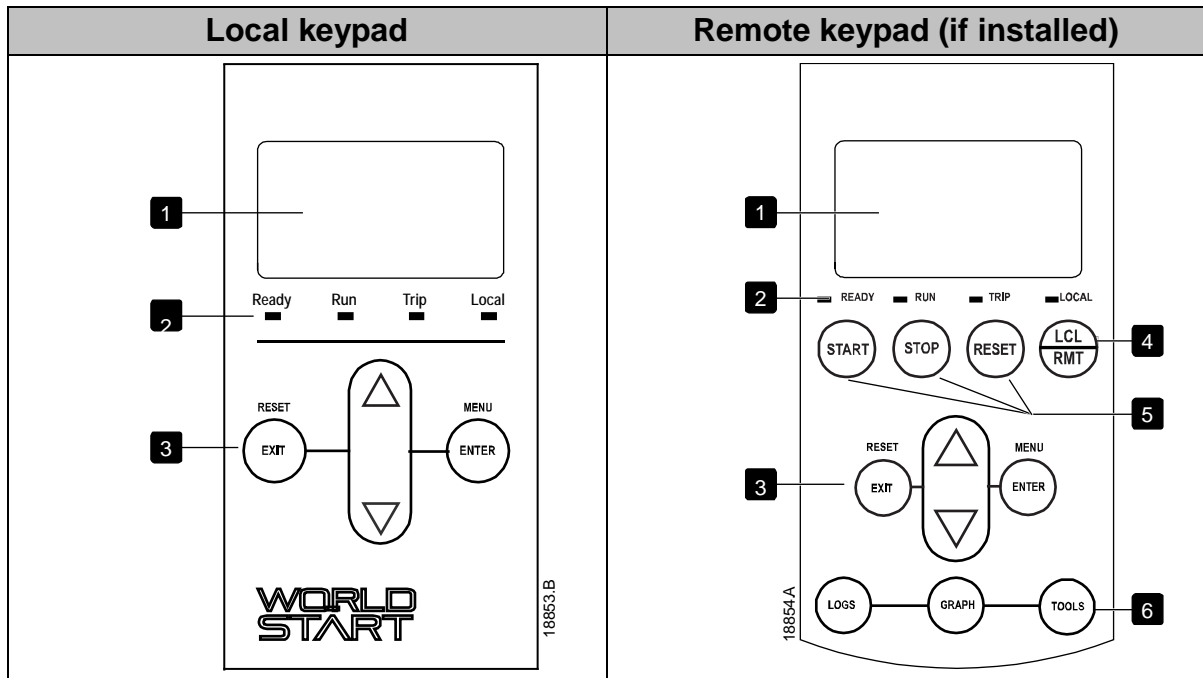

1	Four-line display for status and programming details.
2	Status LEDs.
3	Menu navigation buttons: EXIT/RESET: Exit the menu or parameter, or cancel a parameter change. On the local keypad, this button also resets a trip. ENTER/MENU: Enter a menu or parameter, or save a parameter change. ▲ ▼: Scroll to the next or previous menu or parameter, change the setting of the current parameter or scroll through the status screens.
4	Shortcut to the command source menu in Setup Tools.
5	Soft starter local control buttons
6	Shortcut buttons for quick access to common tasks. LOGS: Open the Logs Menu. GRAPH: Select which graph to view, or pause/restart the graph (hold longer than 0.5 seconds) TOOLS: Open the Setup Tools.

7.2 Remote Keypad

The remote keypad can be used to control the soft starter if parameter 1A *Command Source* is set to 'Remote Keypad'.

- If the remote keypad is not selected as the command source, the **START**, **STOP** and **RESET** buttons will have no effect.
- The menu navigation buttons and display on the remote keypad are always active.
- If a button is pressed on the starter's local keypad, the display on the remote keypad will update to match.



NOTE

The remote keypad can be safely connected or removed while the starter is running. It is not necessary to remove mains or control voltage.



NOTE

If parameter 1A *Command Source* is set to Remote Keypad, removing the remote keypad will cause a trip.

7.3 Starter status LEDs

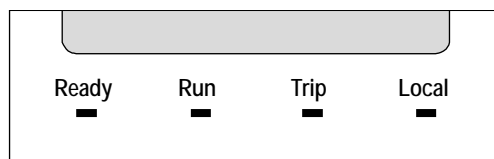

LED name	On	Flashing
Ready	The motor is stopped and the starter is ready to start.	The motor is stopped and the starter is not ready to start: <ul style="list-style-type: none"> • waiting for the <i>Restart Delay</i> (parameter 5H) • the thermal models indicate the starter and/or motor are too hot to start safely • the reset input (10, 11) is open
Run	The motor is in run state (receiving full voltage).	The motor is starting or stopping.
Trip	The starter has tripped.	The starter is in warning state.
Local	The starter is being controlled via a remote keypad.	–

If all LEDs are off, the starter is not receiving control voltage.

8 Operation

8.1 Start, Stop and Reset Commands

The WSB can be started and stopped via the digital inputs, remote keypad, communication network or smart card. The command source can be set via the Setup Tools, or using parameter 1A *Command Source*.

- The WSB will only accept Start and Reset commands from the designated command source.
- The WSB will accept Stop commands from the designated command source, but can be forced to stop by opening the reset input.
- The programmable input can be used to override the selected command source (refer to parameter 7A *Input A Function*).

8.2 Command Override

The programmable input (13, 14) can be used to override the command source, for situations where the normal control mechanism has been lost. Set parameter 7A *Input A Function* to the alternative command source (eg 'Command Override: Keypad').

While the input is active, the starter will only accept commands from the selected override source. To restore control to the command source selected in parameter 1A *Command Source*, reopen the input.

8.3 Emergency Mode

Emergency mode allows the WSB to run the motor and ignore trip conditions.

Emergency mode is controlled via a programmable input (input A 13, 14 or input B 13, 15) and parameter 7A *Input A Function*/7E *Input B Function* must be set to 'Emergency Mode'. A closed circuit across 13, 14 activates emergency mode. When the WSB receives a start command, it will continue to run until a stop command is received, ignoring all trips and warnings.

Emergency mode can be used in conjunction with any command source.



NOTE

Although emergency mode operation satisfies the functionality requirements of Fire Mode, WorldWide Electric does not recommend its use in situations that require testing and/or compliance with specific standards as it is not certified.



CAUTION

Continued use of emergency mode is not recommended. Emergency mode may compromise the starter and/or motor life as all protections and trips are disabled.

Using the starter in emergency mode will void the product warranty.

8.4 Auxiliary Trip

An external trip circuit (such as a low pressure alarm switch for a pumping system) can be used to trip the soft starter and stop the motor. The external circuit is connected to a programmable input (input A 13, 14 or input B 13, 15). To control the behaviour of the trip, set the following parameters:

- Parameter 7A *Input A Function*: select 'Input Trip (N/O)'.
- Parameter 7B *Input A Trip*: set as required. For example, 'Run Only' limits the input trip to when the soft starter is running only.
- Parameter 7C *Input A Trip Delay*: sets a delay between the input activating and the soft starter tripping.
- Parameter 7D *Input A Initial Delay*: sets a delay before the soft starter monitors the state of the input, after the start signal. For example, a delay may be required to allow time for pipeline pressure to build up.
- Parameter 7J *Input A Name*: select a name, eg 'Input A Trip' (optional).

8.5 Typical Control Methods

The requirements of an application differ between each installation, but the methods listed below are often a good starting point for common applications.

Application	Start Mode	Start Ramp Time (seconds)	Initial Current (%FLC)	Current Limit (%FLC)	Stop Mode	Stop Time (seconds)
Bow thruster	Constant Current	5	100	400	Coast To Stop	n/a
Centrifuge (Separator)	Constant Current	1	200	450	Coast To Stop	n/a
Chipper	Constant Current	1	200	450	Coast To Stop	n/a
Compressor - reciprocating - loaded	Constant Current	1	200	450	Coast To Stop	n/a
Compressor - reciprocating - unloaded	Constant Current	1	200	400	Coast To Stop	n/a
Compressor - screw - loaded	Constant Current	1	200	400	Coast To Stop	n/a
Compressor - screw - unloaded	Constant Current	1	200	350	Coast To Stop	n/a
Conveyor - horizontal	Constant Current	5	200	400	TVR Soft Stop	10
Conveyor - inclined	Constant Current	2	200	450	Coast To Stop	n/a

Application	Start Mode	Start Ramp Time (seconds)	Initial Current (%FLC)	Current Limit (%FLC)	Stop Mode	Stop Time (seconds)
Conveyor - vertical (bucket)	Constant Current	2	200	450	Coast To Stop	n/a
Crusher - cone	Constant Current	1	200	350	Coast To Stop	n/a
Crusher - jaw	Constant Current	1	200	450	Coast To Stop	n/a
Crusher - rotary	Constant Current	1	200	400	Coast To Stop	n/a
Debarker	Constant Current	1	200	350	Coast To Stop	n/a
Fan - axial (damped)	Constant Current	1	200	350	Coast To Stop	n/a
Fan - axial (undamped)	Constant Current	1	200	450	Coast To Stop	n/a
Fan - centrifugal (damped)	Constant Current	1	200	350	Coast To Stop	n/a
Fan - centrifugal (undamped)	Constant Current	1	200	450	Coast To Stop	n/a
Fan - high pressure	Constant Current	1	200	450	Coast To Stop	n/a
Mill - ball	Constant Current	1	200	450	Coast To Stop	n/a
Mill - hammer	Constant Current	1	200	450	Coast To Stop	n/a
Pump - bore	Adaptive Control (Const. accel.)	3	n/a	500	Adaptive Control (Const. decel.)	3
Pump - centrifugal	Adaptive Control (Const. accel.)	10	n/a	500	Adaptive Control (Const. decel.)	15
Pump - Hydraulic	Constant Current	2	200	350	Coast To Stop	n/a
Pump - positive displacement	Adaptive Control (Constant accel.)	10	n/a	400	Adaptive Control (Constant decel.)	10

Application	Start Mode	Start Ramp Time (seconds)	Initial Current (%FLC)	Current Limit (%FLC)	Stop Mode	Stop Time (seconds)
Pump - submersible	Adaptive Control (Const. accel.)	5	n/a	500	Adaptive Control (Const. decel.)	5
Saw - bandsaw	Constant Current	1	200	450	Coast To Stop	n/a
Saw - circular	Constant Current	1	200	350	Coast To Stop	n/a
Shredder	Constant Current	1	200	450	Coast To Stop	n/a

8.6 Soft Start Methods

Constant Current

Constant current is the traditional form of soft starting, which raises the current from zero to a specified level and keeps the current stable at that level until the motor has accelerated.

Constant current starting is ideal for applications where the start current must be kept below a particular level.

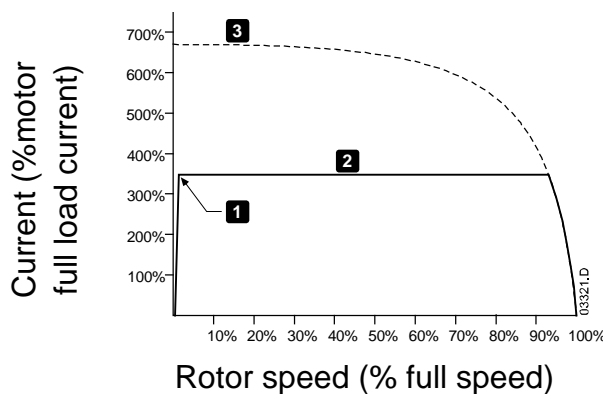

- 1: Initial Current (parameter 2C)
- 2: Current Limit (parameter 2D)
- 3: Full voltage current

Constant Current with Current Ramp

Current ramp soft starting raises the current from a specified starting level (1) to a maximum limit (3), over an extended period of time (2).

Current ramp starting can be useful for applications where:

- the load can vary between starts (for example a conveyor which may start loaded or unloaded). Set the initial current (parameter 2C) to a level that will start the motor with a light load, and the current limit (parameter 2D) to a level that will start the motor with a heavy load.
- the load breaks away easily, but starting time needs to be extended (for example a centrifugal pump where pipeline pressure needs to build up slowly).

- the electricity supply is limited (for example a generator set), and a slower application of load will allow greater time for the supply to respond.

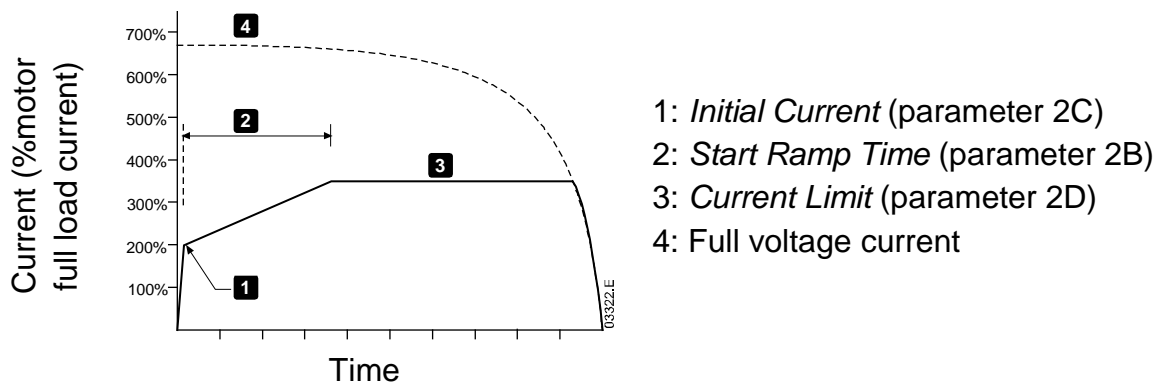

Adaptive Control for Starting

In an adaptive control soft start, the WSB adjusts the current in order to start the motor within a specified time.



NOTE

The WSB will apply the current limit on all soft starts, including adaptive control. If the current limit is too low or the start ramp time (parameter 2B) is too short, the motor may not start successfully.

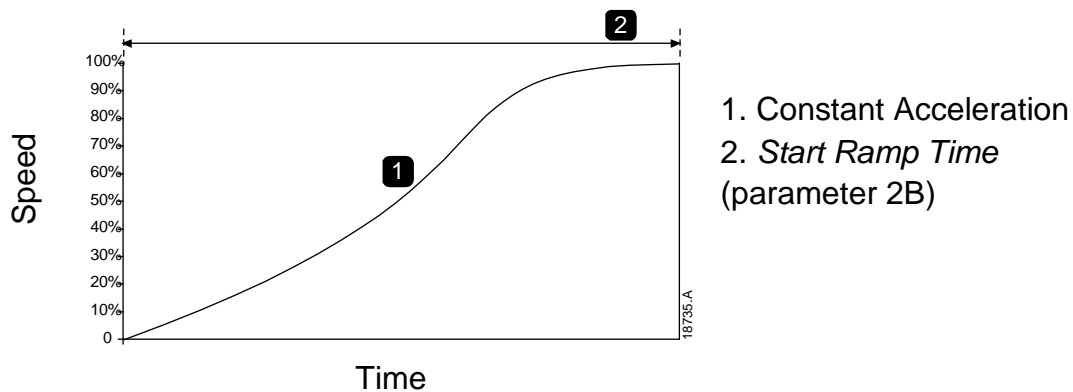

Fine-tuning Adaptive Control

If the motor does not start or stop smoothly, adjust the adaptive control gain (parameter 2I). The gain setting determines how much the WSB will adjust future adaptive control starts and stops, based on information from the previous start. The gain setting affects both starting and stopping performance.

- If the motor accelerates or decelerates too quickly at the end of a start or stop, increase the gain setting by 5%~10%.
- If the motor speed fluctuates during starting or stopping, decrease the gain setting slightly.



NOTE

The WSB tunes Adaptive Control to match the motor. Changing the following parameters will reset Adaptive Control and the first start/stop cycle will use constant current start/timed voltage ramp stop: 1B *Motor Full Load Current*, 2D *Current Limit*, 2I *Adaptive Control Gain*.

8.7 Stop Methods

Coast to Stop

Coast to stop lets the motor slow at its natural rate, with no control from the soft starter. The time required to stop will depend on the type of load.

TVR Soft Stop

Timed voltage ramp reduces the voltage to the motor gradually over a defined time. The load may continue to run after the stop ramp is complete.

Timed voltage ramp stopping can be useful for applications where the stop time needs to be extended, or to avoid transients on generator set supplies.

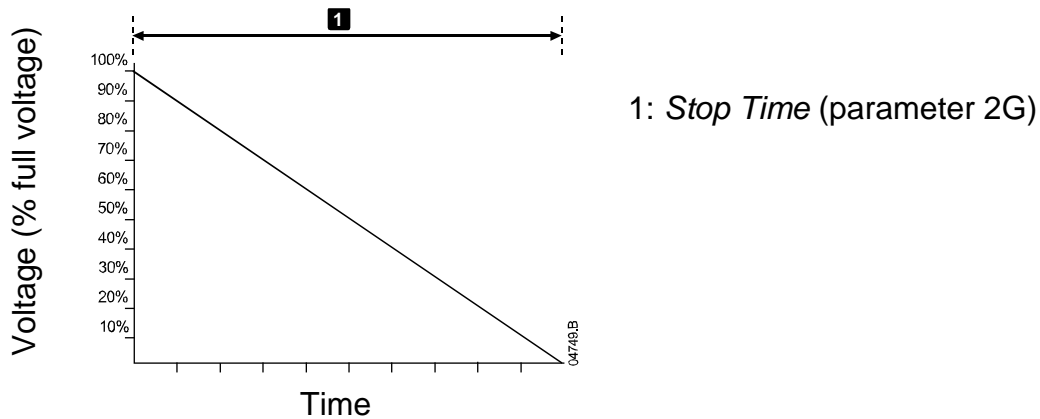

Adaptive Control for Stopping

In an adaptive control soft stop, the WSB controls the current in order to stop the motor within a specified time. Adaptive Control can be useful in extending the stopping time of low inertia loads.

The first Adaptive Control stop will be a normal soft stop. This allows the WSB to learn the characteristics of the connected motor. This motor data is used by the WSB during subsequent Adaptive Control stops.

If replacing a motor connected to a WSB programmed for Adaptive Control starting or stopping, the starter will need to learn the characteristics of the new motor. Change the value of parameter 1B *Motor Full Load Current* or parameter 2I *Adaptive Control Gain* to initiate the re-learning process. The next start will use constant current and the next stop will use timed voltage ramp.

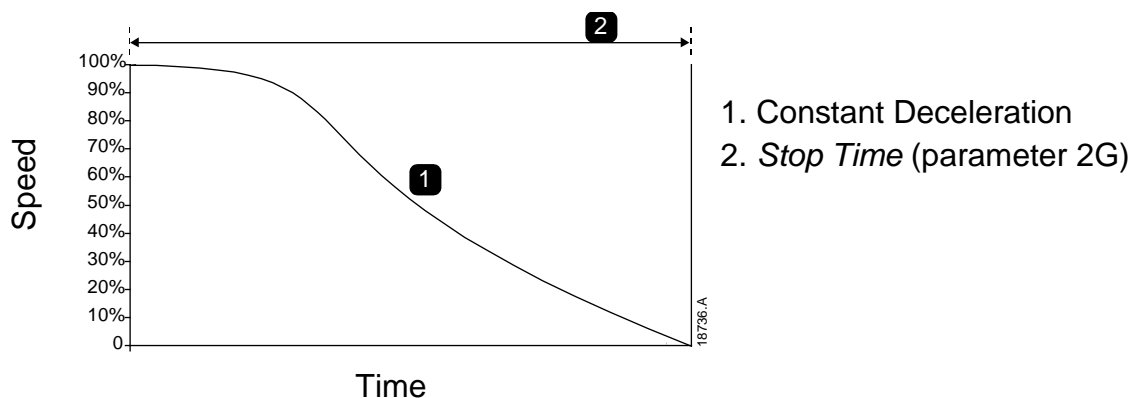

Adaptive Control is ideal for pumping applications, where it can minimise the damaging effects of fluid hammer.

9 Programmable Parameters

9.1 Programming Menu

The Programming Menu lets you view and change programmable parameters that control how the WSB operates.

To open the Programming Menu, press the **MENU/ENTER** button while viewing the monitoring screens.

9.2 Altering Parameter Values

To change a parameter value:

- scroll to the appropriate parameter in the Programming Menu and press **ENTER/MENU** to enter edit mode.
- to alter the parameter setting, use the **▲** and **▼** buttons. Pressing **▲** or **▼** once will increase or decrease the value by one unit. If the button is held for longer than five seconds, the value will increase or decrease at a faster rate.
- to save changes, press **ENTER**. The setting shown on the display will be saved and the keypad will return to the parameter list.
- to cancel changes, press **EXIT**. The keypad will ask for confirmation, then return to the parameter list without saving changes.

9.3 Adjustment Lock

You can prevent users from altering parameter settings by turning on the adjustment lock (parameter 10G *Adjustment Lock*).

If a user attempts to change a parameter value when the adjustment lock is active, an error message is displayed:

Access Denied
Adj Lock is On

9.4 Parameter List

	Parameter Group	Default Setting
1	Motor Details	
1A	<i>Command Source</i>	Digital Input
1B	<i>Motor Full Load Current</i>	Model dependent
1C	<i>Locked Rotor Time</i>	00:10 (mm:ss)
1D	<i>Locked Rotor Current</i>	600%
1E	<i>Motor Service Factor</i>	105%
2	Motor Start/Stop	
2A	<i>Start Mode</i>	Constant Current
2B	<i>Start Ramp Time</i>	00:10 (mm:ss)
2C	<i>Initial Current</i>	200%
2D	<i>Current Limit</i>	350%
2E	<i>Adaptive Start Profile</i>	Constant Acceleration
2F	<i>Stop Mode</i>	TVR Soft Stop
2G	<i>Stop Time</i>	00:01 (mm:ss)
2H	<i>Adaptive Stop Profile</i>	Constant Deceleration

	Parameter Group	Default Setting
2I	<i>Adaptive Control Gain</i>	75%
2J	<i>Multi Pump</i>	Single Pump
2K	<i>Start Delay</i>	00:00 (mm:ss)
5	Protection Levels	
5A	<i>Current Imbalance</i>	30%
5B	<i>Current Imbalance Delay</i>	00:03 (mm:ss)
5C	<i>Undercurrent</i>	20%
5D	<i>Undercurrent Delay</i>	00:05 (mm:ss)
5E	<i>Overcurrent</i>	400%
5F	<i>Overcurrent Delay</i>	00:00 (mm:ss)
5G	<i>Excess Start Time</i>	00:20 (mm:ss)
5H	<i>Restart Delay</i>	00:10 (mm:ss)
6	Protection Actions	
6A	<i>Current Imbalance</i>	Soft Trip and Log
6B	<i>Undercurrent</i>	Soft Trip and Log
6C	<i>Overcurrent</i>	Soft Trip and Log
6D	<i>Excess Start Time</i>	Soft Trip and Log
6E	<i>Input A Trip</i>	Soft Trip and Log
6F	<i>Input B Trip</i>	Soft Trip and Log
6G	<i>Network Communications</i>	Soft Trip and Log
6H	<i>Remote Keypad Fault</i>	Soft Trip and Log
6I	<i>Frequency</i>	Soft Trip and Log
6J	<i>Motor Overtemperature</i>	Soft Trip and Log
6K	<i>Motor Thermistor Circuit</i>	Soft Trip and Log
6L	<i>Pressure Sensor</i>	Soft Trip and Log
6M	<i>Flow Sensor</i>	Soft Trip and Log
6N	<i>Depth Sensor</i>	Soft Trip and Log
6O	<i>High Pressure</i>	Soft Trip and Log
6P	<i>Low Pressure</i>	Soft Trip and Log
6Q	<i>High Flow</i>	Soft Trip and Log
6R	<i>Low Flow</i>	Soft Trip and Log
6S	<i>Flow Switch</i>	Soft Trip and Log
6T	<i>Well Depth</i>	Soft Trip and Log
6U	<i>RTD/PT100 B</i>	Soft Trip and Log
7	Inputs	
7A	<i>Input A Function</i>	Input Trip (N/O)
7B	<i>Input A Trip</i>	Operating Only
7C	<i>Input A Trip Delay</i>	00:00 (mm:ss)
7D	<i>Input A Initial Delay</i>	00:00 (mm:ss)
7E	<i>Input B Function</i>	Input Trip (N/O)

	Parameter Group	Default Setting
7F	<i>Input B Trip</i>	Operating Only
7G	<i>Input B Trip Delay</i>	00:00 (mm:ss)
7H	<i>Input B Initial Delay</i>	00:00 (mm:ss)
7I	<i>Reset/Enable Logic</i>	Normally Closed (N/C)
7J	<i>Input A Name</i>	Input A Trip
7K	<i>Input B Name</i>	Input B Trip
8	Relay Outputs	
8A	<i>Relay A Function</i>	Run
8B	<i>Relay A On Delay</i>	00:00 (mm:ss)
8C	<i>Relay A Off Delay</i>	00:00 (mm:ss)
8D	<i>Relay B Function</i>	Run
8E	<i>Relay B On Delay</i>	00:00 (mm:ss)
8F	<i>Relay B Off Delay</i>	00:00 (mm:ss)
8G	<i>Low Current Flag</i>	50%
8H	<i>High Current Flag</i>	100%
8I	<i>Motor Temperature Flag</i>	80%
8J	<i>Main Contactor Time</i>	400 ms
9	Analog Output	
9A	<i>Analog Output A</i>	Current (% FLC)
9B	<i>Analog A Scale</i>	4-20 mA
9C	<i>Analog A Maximum Adjustment</i>	100%
9D	<i>Analog A Minimum Adjustment</i>	000%
10	Display	
10A	<i>Language</i>	English
10B	<i>Temperature Scale</i>	Celsius
10C	<i>Graph Timebase</i>	30 seconds
10D	<i>Graph Maximum Adjustment</i>	400%
10E	<i>Graph Minimum Adjustment</i>	0%
10F	<i>Current Calibration</i>	100%
10G	<i>Adjustment Lock</i>	Read & Write
10H	<i>User Parameter 1</i>	Blank
10I	<i>User Parameter 2</i>	Blank
11	Communications Card	
11A	<i>Modbus Address</i>	1
11B	<i>Modbus Baud Rate</i>	9600
11C	<i>Modbus Parity</i>	None
11D	<i>Modbus Timeout</i>	Off
11E	<i>Devicenet Address</i>	0
11F	<i>Devicenet Baud Rate</i>	125kB

	Parameter Group	Default Setting
11G	<i>Profibus Address</i>	1
11H	<i>Gateway Address</i>	192
11I	<i>Gateway Address 2</i>	168
11J	<i>Gateway Address 3</i>	0
11K	<i>Gateway Address 4</i>	100
11L	<i>IP Address</i>	192
11M	<i>IP Address 2</i>	168
11N	<i>IP Address 3</i>	0
11O	<i>IP Address 4</i>	2
11P	<i>Subnet Mask</i>	255
11Q	<i>Subnet Mask 2</i>	255
11R	<i>Subnet Mask 3</i>	255
11S	<i>Subnet Mask 4</i>	0
11T	<i>DHCP</i>	Disable
11U	<i>Location ID</i>	0
12	Pump Input Configuration	
12A	<i>Auto-Reset Count</i>	0
12B	<i>Auto-Reset Delay</i>	00:05 (mm:ss)
12C	<i>Pressure Sensor Type</i>	None
12D	<i>Pressure Units</i>	kPa
12E	<i>Pressure at 4 mA</i>	0
12F	<i>Pressure at 20 mA</i>	0
12G	<i>Flow Sensor Type</i>	None
12H	<i>Flow Units</i>	litres/second
12I	<i>Flow at 4 mA</i>	0
12J	<i>Flow at 20 mA</i>	0
12K	<i>Units per Minute at Max Flow</i>	0
12L	<i>Pulses per Minute at Max Flow</i>	0
12M	<i>Units per Pulse</i>	0
12N	<i>Depth Sensor Type</i>	None
12O	<i>Depth Units</i>	metres
12P	<i>Depth at 4 mA</i>	0
12Q	<i>Depth at 20 mA</i>	0
13	Flow Protection	
13A	<i>High Flow Trip Level</i>	10
13B	<i>Low Flow Trip Level</i>	5
13C	<i>Flow Start Delay</i>	00:00:50 (mm:ss:ms)
13D	<i>Flow Response Delay</i>	00:00:50 (mm:ss:ms)
14	Pressure Protection	
14A	<i>High Pressure Trip Level</i>	10

	Parameter Group	Default Setting
14B	<i>High Pressure Start Delay</i>	00:00:50 (mm:ss:ms)
14C	<i>High Pressure Response Delay</i>	00:00:50 (mm:ss:ms)
14D	<i>Low Pressure Trip Level</i>	5
14E	<i>Low Pressure Start Delay</i>	00:00:50 (mm:ss:ms)
14F	<i>Low Pressure Response Delay</i>	00:00:50 (mm:ss:ms)
15	Pressure Control	
15A	<i>Pressure Control Mode</i>	Off
15B	<i>Start Pressure Level</i>	5
15C	<i>Start Response Delay</i>	00:00:50 (mm:ss:ms)
15D	<i>Stop Pressure Level</i>	10
15E	<i>Stop Response Delay</i>	00:00:50 (mm:ss:ms)
16	Depth Protection	
16A	<i>Depth Trip Level</i>	5
16B	<i>Depth Reset Level</i>	10
16C	<i>Depth Start Delay</i>	00:00:50 (mm:ss:ms)
16D	<i>Depth Response Delay</i>	00:00:50 (mm:ss:ms)
17	Thermal Protection	
17A	<i>Temperature Sensor Type</i>	None
17B	<i>Temperature Trip Level</i>	40
20	Advanced	
20A	<i>Tracking Gain</i>	50%
20B	<i>Pedestal Detect</i>	80%
20C	<i>Bypass Contactor Delay</i>	150 ms
20D	<i>Model Rating</i>	0020
20E	<i>Screen Timeout</i>	1 minute

9.5 1 Motor Details

1A – Command Source

Options:	Digital Input (default)	The WSB will accept start and stop commands from the digital inputs.
	Network	The WSB will accept start and stop commands from the communication expansion card.
	Remote Keypad	The WSB will accept start and stop commands from the Remote Keypad.
	Smart Card	The WSB will accept start and stop commands from the smart card.

Description: Selects the command source for controlling the soft starter.

1B – Motor Full Load Current

Range: Model dependent**Description:** Matches the starter to the connected motor's full load current. Set to the full load current (FLC) rating shown on the motor nameplate.**1C – Locked Rotor Time**

Range: 0:01 - 2:00 (minutes:seconds) **Default:** 10 seconds**Description:** Sets the maximum length of time the motor can sustain locked rotor current from cold before reaching its maximum temperature. Set according to the motor datasheet.**1D – Locked Rotor Current**

Range: 400% - 1200% FLC **Default:** 600%**Description:** Sets the locked rotor current of the connected motor, as a percentage of full load current. Set according to the motor datasheet.**1E – Motor Service Factor**

Range: 100% - 130% **Default:** 105%**Description:** Sets the motor service factor used by the thermal model. If the motor runs at full load current, it will reach 100%. Set according to the motor datasheet.**NOTE**

Parameters 1C, 1D and 1E determine the trip current for motor overload protection. The default settings of parameters 1C, 1D and 1E provide Motor Overload Protection: Class 10, Trip Current 105% of FLA (full load amperage) or equivalent.

9.6 2 Motor Start/Stop**2A – Start Mode**

Options: Constant Current (default)
Adaptive Control**Description:** Selects the soft start mode.**NOTE**

The WSB will apply the current limit on all soft starts, including adaptive control. If the current limit is too low or the start ramp time (parameter 2B) is too short, the motor may not start successfully.

2B – Start Ramp Time

Range: 0:01 - 3:00 (minutes:seconds) **Default:** 10 seconds**Description:** Sets the total start time for an Adaptive Control start or the ramp time for current ramp starting (from the initial current to the current limit).

2C – Initial Current

Range: 100% - 600% FLC **Default:** 200%

Description: Sets the initial start current level for current ramp starting, as a percentage of motor full load current. Set so that the motor begins to accelerate immediately after a start is initiated.
If current ramp starting is not required, set the initial current equal to the current limit.

2D – Current Limit

Range: 100% - 600% FLC **Default:** 350%

Description: Sets the current limit for constant current and current ramp soft starting, as a percentage of motor full load current.

2E – Adaptive Start Profile

Options: Constant Acceleration (default)

Description: Selects which profile the WSB will use for an Adaptive Control soft start.

**NOTE**

The WSB will apply the current limit on all soft starts, including adaptive control. If the current limit is too low or the start ramp time (parameter 2B) is too short, the motor may not start successfully.

2F – Stop Mode

Options: Coast To Stop
TVR Soft Stop (default)
Adaptive Control

Description: Selects the stop mode.

2G – Stop Time

Range: 0:00 - 4:00 (minutes:seconds) **Default:** 1 second

Description: Sets the time for soft stopping the motor using timed voltage ramp or Adaptive Control.
If a main contactor is installed, the contactor must remain closed until the end of the stop time. Use the main contactor output (33, 34) to control the main contactor.

2H – Adaptive Stop Profile

Options: Constant Deceleration (default)

Description: Selects which profile the WSB will use for an Adaptive Control soft stop.

2I – Adaptive Control Gain

Range: 1% - 200% **Default:** 75%

Description: Adjusts the performance of Adaptive Control. This setting affects both starting and stopping control.

2J – Multi Pump

Options: Single Pump (default)
Manifold Pump

Description: Adjusts the performance of adaptive control to suit installations with multiple pumps connected to a common outlet manifold.

2K – Start Delay

Range: 0:00 - 3:20 (minutes:seconds) **Default:** 0 second

Description: Sets a delay after the starter receives a start command, before it starts the motor.

9.7 5 Protection Levels**5A – Current Imbalance**

Range: 10% - 50% **Default:** 30%

Description: Sets the trip point for current imbalance protection.

5B – Current Imbalance Delay

Range: 0:00 - 4:00 (minutes:seconds) **Default:** 3 seconds

Description: Slows the WSB's response to current imbalance, avoiding trips due to momentary fluctuations.

5C – Undercurrent

Range: 0% - 100% **Default:** 20%

Description: Sets the trip point for undercurrent protection, as a percentage of motor full load current. Set to a level between the motor's normal working range and the motor's magnetising (no load) current (typically 25% to 35% of full load current). A setting of 0% disables undercurrent protection.

5D – Undercurrent Delay

Range: 0:00 - 4:00 (minutes:seconds) **Default:** 5 seconds

Description: Slows the WSB's response to undercurrent, avoiding trips due to momentary fluctuations.

5E – Overcurrent

Range: 80% - 600% **Default:** 400%

Description: Sets the trip point for overcurrent protection, as a percentage of motor full load current.

5F – Overcurrent Delay

Range: 0:00 - 1:00 (minutes:seconds) **Default:** 0 second

Description: Slows the WSB's response to overcurrent, avoiding trips due to momentary overcurrent events.

5G – Excess Start Time

Range: 0:00 - 4:00 (minutes:seconds) **Default:** 20 seconds

Description: Excess start time is the maximum time the WSB will attempt to start the motor. If the motor does not transition to Run mode within the programmed limit, the starter will trip. Set for a period slightly longer than required for a normal healthy start. A setting of 0 disables excess start time protection.

5H – Restart Delay

Range: 00:01 - 60:00 (minutes:seconds) **Default:** 10 seconds

Description: The WSB can be configured to force a delay between the end of a stop and the beginning of the next start. During the restart delay period, the display shows the time remaining before another start can be attempted.

9.8 6 Protection Action

6A – Current Imbalance

Options:	Soft Trip and Log (default)	The soft starter will stop the motor as selected in parameter 2F <i>Stop Mode</i> , then enter trip state. The trip must be reset before the WSB can restart.
	Trip Starter	The soft starter will remove power and the motor will coast to stop. The trip must be reset before the WSB can restart.
	Warn and Log	The protection will be written to the event log and the display will show a warning message, but the soft starter will continue to operate.
	Log Only	The protection will be written to the event log but the soft starter will continue to operate.

Description: Selects the soft starter's response to each protection. All protection events are written to the event log.

6B – Undercurrent

Options:	Soft Trip and Log (default)	Warn and Log
	Trip Starter	Log Only

Description: Selects the soft starter's response to the protection event.

6C – Overcurrent

Options:	Soft Trip and Log (default)	Warn and Log
	Trip Starter	Log Only

Description: Selects the soft starter's response to the protection event.

6D – Excess Start Time

Options:	Soft Trip and Log (default)	Warn and Log
	Trip Starter	Log Only

Description: Selects the soft starter's response to the protection event.

6E – Input A Trip

Options:	Soft Trip and Log (default)	Warn and Log
	Trip Starter	Log Only

Description: Selects the soft starter's response to the protection event.

6F – Input B Trip

Options:	Soft Trip and Log (default)	Warn and Log
	Trip Starter	Log Only

Description: Selects the soft starter's response to the protection event.

6G – Network Communications

Options:	Soft Trip and Log (default)	Warn and Log
	Trip Starter	Log Only
	Stop	

Description: Selects the soft starter's response to the protection event. If set to Stop, the WSB will perform a soft stop, then can be restarted without a reset.

6H – Remote Keypad Fault

Options:	Soft Trip and Log (default)	Warn and Log
	Trip Starter	Log Only

Description: Selects the soft starter's response to the protection event.

6I – Frequency

Options:	Soft Trip and Log (default)	Warn and Log
	Trip Starter	Log Only

Description: Selects the soft starter's response to the protection event.

6J – Motor Overtemperature

Options:	Soft Trip and Log (default)	Warn and Log
	Trip Starter	Log Only

Description: Selects the soft starter's response to the protection event.

6K – Motor Thermistor Circuit

Options:	Soft Trip and Log (default)	Warn and Log
	Trip Starter	Log Only

Description: Selects the soft starter's response to the protection event.

6L – Pressure Sensor

Options: Soft Trip and Log (default) Warn and Log
 Trip Starter Log Only

Description: Selects the soft starter's response if it detects a fault with the pressure sensor.

6M – Flow Sensor

Options: Soft Trip and Log (default) Warn and Log
 Trip Starter Log Only

Description: Selects the soft starter's response if it detects a fault with the flow sensor.

6N – Depth Sensor

Options: Soft Trip and Log (default) Warn and Log
 Trip Starter Log Only

Description: Selects the soft starter's response if it detects a fault with the depth sensor.

6O – High Pressure

Options: Soft Trip and Log (default) Warn and Log
 Trip Starter Log Only

Description: Selects the soft starter's response if the pressure exceeds the high pressure trip level (parameter 14A) or the high pressure switch sensor closes.

6P – Low Pressure

Options: Soft Trip and Log (default) Warn and Log
 Trip Starter Log Only

Description: Selects the soft starter's response if the pressure falls below the low pressure trip level (parameter 14D) or the low pressure switch sensor closes.

6Q – High Flow

Options: Soft Trip and Log (default) Warn and Log
 Trip Starter Log Only

Description: Selects the soft starter's response if the flow exceeds the high flow trip level (parameter 13A).

6R – Low Flow

Options: Soft Trip and Log (default) Warn and Log
 Trip Starter Log Only

Description: Selects the soft starter's response if the flow falls below the low flow trip level (parameter 13B).

6S – Flow Switch

Options:	Soft Trip and Log (default)	Warn and Log
	Trip Starter	Log Only

Description: Selects the soft starter's response if the flow sensor closes (switch type sensors only).

6T – Well Depth

Options:	Soft Trip and Log (default)	Warn and Log
	Trip Starter	Log Only

Description: Selects the soft starter's response if the depth falls below the depth trip level (parameter 16A) or the depth switch sensor closes.

6U – RTD/PT100 B

Options:	Soft Trip and Log (default)	Warn and Log
	Trip Starter	Log Only

Description: Selects the soft starter's response to the protection event.

9.9 7 Inputs

7A – Input A Function

Options:	Command	Overrides the setting of 1A and sets the command source to the communications network.
	Override: Network	
	Command	Overrides the setting of 1A and sets the command source to the digital inputs.
	Override: Digital	
	Command	Overrides the setting of 1A and sets the command source to the remote keypad.
	Override: Keypad	
	Input Trip (N/O) (default)	A closed circuit across 13, 14 trips the soft starter.
	Input Trip (N/C)	An open circuit across 13, 14 trips the soft starter.
	Emergency Mode	A closed circuit across 13, 14 activates emergency mode. When the WSB receives a start command, it will continue to run until a stop command is received, ignoring all trips and warnings.

Description: Selects the function of Input A.

7B – Input A Trip

Options:	Always Active	A trip can occur at any time when the soft starter is receiving power.
	Operating Only (default)	A trip can occur while the soft starter is running, stopping or starting.
	Run Only	A trip can only occur while the soft starter is running.

Description: Selects when an input trip can occur.

7C – Input A Trip Delay

Range: 0:00 - 4:00 (minutes:seconds) **Default:** 0 second

Description: Sets a delay between the input activating and the soft starter tripping.

7D – Input A Initial Delay

Range: 00:00 - 30:00 (minutes:seconds) **Default:** 0 second

Description: Sets a delay before an input trip can occur. The initial delay is counted from the time a start signal is received. The state of the input is ignored until the initial delay has elapsed.

7E – Input B Function

Options: Input Trip (N/O) (default)
Input Trip (N/C)
Emergency Mode

Description: Selects the function of Input B. Refer to parameter 7A *Input A Function* for details.

7F – Input B Trip

Options: Always Active
Operating Only (default)
Run Only

Description: Selects when an input trip can occur.

7G – Input B Trip Delay

Range: 0:00 - 4:00 (minutes:seconds) **Default:** 0 second

Description: Sets a delay between the input activating and the soft starter tripping.

7H – Input B Initial Delay

Range: 00:00 - 30:00 (minutes:seconds) **Default:** 0 second

Description: Sets a delay before an input trip can occur. The initial delay is counted from the time a start signal is received. The state of the input is ignored until the initial delay has elapsed.

7I – Reset/Enable Logic

Options: Normally Closed (default)
Normally Open

Description: Selects whether the reset input (10, 11) is normally open or normally closed.

**NOTE**

If the reset input is active, the starter will not operate.

7J – Input A Name

Options: Input A Trip (default)
Custom Message

Description: Selects a message for the keypad to display when Input A is active. The custom message can be loaded via the USB port. Refer to *USB Save & Load* on page 34 for details.

7K – Input B Name

Options: Input B Trip (default)
Custom Message

Description: Selects a message for the keypad to display when Input B is active.

9.10 8 Relay Outputs**8A – Relay A Function**

Options:	Off	Relay A is not used.
	Ready	The relay is closed when the starter is in Ready state.
	Run (default)	The Run output closes when the soft start is complete (when the starting current falls below 120% of the programmed motor full load current) and remains closed until the beginning of a stop (either soft stop or coast to stop).
	Warning	The relay closes when the starter issues a warning (refer to <i>6 Protection Action</i> on page 56).
	Trip	The relay closes when the starter trips (refer to <i>6 Protection Action</i> on page 56).
	Low Current Flag	The relay closes when the low current flag activates while the motor is running (refer to parameter 8G <i>Low Current Flag</i>).
	High Current Flag	The relay closes when the high current flag activates while the motor is running (refer to parameter 8H <i>High Current Flag</i>).
	Motor Temperature Flag	The relay closes when the motor temperature flag activates (refer to parameter 8I <i>Motor Temperature Flag</i>).

Description: Selects the function of Relay A. Relay A is a changeover relay.

8B – Relay A On Delay

Range: 0:00 - 5:00 (minutes:seconds) **Default:** 0 second

Description: Sets the delay for changing the state of Relay A.

8C – Relay A Off Delay

Range: 0:00 - 5:00 (minutes:seconds) **Default:** 0 second

Description: Sets the delay for changing the state of Relay A.

8D – Relay B Function

Options:	Off	Trip
	Ready	Low Current Flag
	Run (default)	High Current Flag
	Warning	Motor Temperature Flag

Description: Selects the function of Relay B (normally open). Refer to parameter 8A *Relay A Function* for details.

8E – Relay B On Delay

Range: 0:00 - 5:00 (minutes:seconds) **Default:** 0 second

Description: Sets the delay for closing Relay B.

8F – Relay B Off Delay

Range: 0:00 - 5:00 (minutes:seconds) **Default:** 0 second

Description: Sets the delay for re-opening Relay B.

8G – Low Current Flag

The WSB has low and high current flags to give early warning of abnormal operation. The current flags can be configured to indicate an abnormal current level during operation, between the normal operating level and the undercurrent or instantaneous overcurrent trip levels. The flags can signal the situation to external equipment via one of the programmable outputs.

The flags clear when the current returns within the normal operating range by 10% of the programmed flag value.

Range: 1% - 100% FLC **Default:** 50%

Description: Sets the level at which the low current flag operates, as a percentage of motor full load current.

8H – High Current Flag

Range: 50% - 600% FLC **Default:** 100%

Description: Sets the level at which the high current flag operates, as a percentage of motor full load current.

8I – Motor Temperature Flag

The WSB has a motor temperature flag to give early warning of abnormal operation. The flag can indicate that the motor is operating above its normal operating temperature but lower than the overload limit. The flag can signal the situation to external equipment via one of the programmable outputs.

Range: 0% - 160% **Default:** 80%

Description: Sets the level at which the motor temperature flag operates, as a percentage of the motor's thermal capacity.

10B – Temperature Scale

Options: Celsius (default)
Fahrenheit

Description: Selects whether the WSB will display temperatures in degrees Celsius or Fahrenheit.

10C – Graph Timebase

Options: 30 seconds (default)
1 minute
30 minutes
1 hour

Description: Sets the graph time scale. The graph will progressively replace the old data with new data.

10D – Graph Maximum Adjustment

Range: 0% – 600% **Default:** 400%

Description: Adjusts the upper limit of the performance graph.

10E – Graph Minimum Adjustment

Range: 0% – 600% **Default:** 0%

Description: Adjusts the lower limit of the performance graph.

10F – Current Calibration

Range: 85% - 115% **Default:** 100%

Description: Calibrates the soft starter's current monitoring circuits to match an external current metering device.

Use the following formula to determine the necessary adjustment:

$$\text{Calibration (\%)} = \frac{\text{Current shown on WSB display}}{\text{Current measured by external device}}$$

10G – Adjustment Lock

Options:	Read & Write (default)	Allows users to alter parameter values in the Programming Menu.
	Read Only	Prevents users altering parameter values in the Programming Menu. Parameter values can still be viewed.

Description: Selects whether the keypad will allow parameters to be changed via the Programming Menu.

10H – User Parameter 1

Options:	Blank (default)	Displays no data in the selected area, allowing long messages to be shown without overlapping.
	Motor pf	The motor's power factor, measured by the soft starter.
	Mains Frequency	The average frequency measured on three phases.
	Analog Output Value	The value of the analog output (refer to parameters 9A~9D).
	Motor Temp (%)	The motor's temperature, calculated by the thermal model.
	Heatsink Temperature	The soft starter's temperature, measured at the heatsink.
	Bypass Model (%)	The percentage of thermal capacity remaining in the bypass contactor.
	SCR Temperature	The temperature of the SCRs, calculated by the thermal model.
	Rating Capacity (%)	The thermal capacity available in the soft starter for its next start.
	Number of Starts	The number of starts the WSB has completed since the start counter was last reset.
	Hours Run	The number of hours the motor has run via the soft starter.
	Pump Pressure	The pressure at the pump, as configured in parameters 12D~12F. This information is only available if the smart card is installed.
	Pump Flow	The flow at the pump, as configured in parameters 12H~12M. This information is only available if the smart card is installed.
	Well Depth	The depth of the well, as configured in parameters 12O~12Q. This information is only available if the smart card is installed.
	Pump Temperature	The pump temperature, as measured by the PT100. This information is only available if the smart card is installed.

Description: Selects which information will be displayed on the programmable monitoring screen.

11F – Devicenet Baud Rate

Options: 125 kB (default)
250 kB
500 kB

Description: Selects the baud rate for DeviceNet communications.

11G – Profibus Address

Range: 1 - 125 **Default:** 1

Description: Sets the Profibus network address for the soft starter.

11H – Gateway Address

Range: 0 - 255 **Default:** 192

Description: Sets the first component of the network gateway address. The gateway address is set using parameters 11H~11K and the default address is 192.168.0.100.

11I – Gateway Address 2

Range: 0 - 255 **Default:** 168

Description: Sets the second component of the network gateway address.

11J – Gateway Address 3

Range: 0 - 255 **Default:** 0

Description: Sets the third component of the network gateway address.

11K – Gateway Address 4

Range: 0 - 255 **Default:** 100

Description: Sets the fourth component of the network gateway address.

**NOTE**

The network address can also be set via the Network Address options in the Setup Tools. Refer to *Network Address* on page 35 for details.

11L – IP Address

Range: 0 - 255 **Default:** 192

Description: Sets the first component of the soft starter's IP address, for Ethernet communications. The IP address is set using parameters 11L~11O and the default address is 192.168.0.2.

11M – IP Address 2

Range: 0 - 255 **Default:** 168

Description: Sets the second component of the soft starter's IP address, for Ethernet communications.

11N – IP Address 3

Range: 0 - 255 **Default:** 0

Description: Sets the third component of the soft starter's IP address, for Ethernet communications.

11O – IP Address 4

Range: 0 - 255 **Default:** 2

Description: Sets the fourth component of the soft starter's IP address, for Ethernet communications.

**NOTE**

The network address can also be set via the Network Address options in the Setup Tools. Refer to *Network Address* on page 35 for details.

11P – Subnet Mask

Range: 0 - 255 **Default:** 255

Description: Sets the first component of the network subnet mask, for Ethernet communications. The subnet mask is set using parameters 11P~11S and the default mask is 255.255.255.0.

11Q – Subnet Mask 2

Range: 0 - 255 **Default:** 255

Description: Sets the second component of the network subnet mask, for Ethernet communications.

11R – Subnet Mask 3

Range: 0 - 255 **Default:** 255

Description: Sets the third component of the network subnet mask, for Ethernet communications.

11S – Subnet Mask 4

Range: 0 - 255 **Default:** 0

Description: Sets the fourth component of the network subnet mask, for Ethernet communications.

**NOTE**

The network address can also be set via the Network Address options in the Setup Tools. Refer to *Network Address* on page 35 for details.

11T – DHCP

Options: Disable (default)
Enable

Description: Selects whether the communications card will accept an IP address assigned by DHCP.

**NOTE**

DHCP addressing is available with Modbus TCP and Ethernet/IP. DHCP addressing is not supported with Profinet.

11U – Location ID

Range: 0 - 65535 **Default:** 0

Description: Sets the soft starter's unique location ID.

9.14 12 Pump Input Configuration**NOTE**

The parameters in this group are only active if a smart card is installed.

12A – Auto-Reset Count

Range: 0 – 5 **Default:** 0

Description: Sets how many times the soft starter will auto-reset, if it continues to trip.

The reset counter increases by one each time the soft starter auto-resets, and resets after a successful start.

Setting 12A to zero disables auto-reset.

**NOTE**

Auto-reset will reset trips from any source, not just from the smart card.

12B – Auto-Reset Delay

Range: 0:05 - 15:00 (minutes:seconds) **Default:** 5 seconds

Description: Sets a delay before the WSB will auto-reset a trip.

12C – Pressure Sensor Type

Options: None (default)
Switch
Analog

Description: Selects which type of sensor is associated with the pressure sensor input on the smart card.

12D – Pressure Units

Options: Bar
kPa (default)
Psi

Description: Selects which units the sensor will use to report the measured pressure.

12E – Pressure at 4 mA

Range: 0 – 5000 **Default:** 0

Description: Calibrates the soft starter to the 4 mA (0%) level of the pressure sensor input.

12F – Pressure at 20 mA

Range: 0 – 5000 **Default:** 0

Description: Calibrates the soft starter to the 20 mA (100%) level of the pressure sensor input.

12G – Flow Sensor Type

Options: None (default) Pulses per minute
Switch Pulses per unit
Analog

Description: Selects which type of sensor is associated with the flow sensor input on the smart card.

12H – Flow Units

Options: litres/second (default)
litres/minute
gallons/second
gallons/minute

Description: Selects which units the sensor will use to report the measured flow.

12I – Flow at 4 mA

Range: 0 – 5000 **Default:** 0

Description: Calibrates the soft starter to the 4 mA (0%) level of the flow sensor input.

12J – Flow at 20 mA

Range: 0 – 5000 **Default:** 0

Description: Calibrates the soft starter to the 20 mA (100%) level of the flow sensor input.

12K – Units per Minute at Max Flow

Range: 0 – 5000 **Default:** 0

Description: Calibrates the soft starter to the maximum flow volume of the flow sensor.

12L – Pulses per Minute at Max Flow

Range: 0 – 20000 **Default:** 0

Description: Calibrates the soft starter to the maximum flow volume of the flow sensor.

12M – Units per Pulse

Range: 0 – 1000 **Default:** 0

Description: Set to match how many units the flow sensor will measure for each pulse.

12N – Depth Sensor Type

Options: None (default)
Switch
Analog

Description: Selects which type of sensor is associated with the depth sensor input on the smart card.

12O – Depth Units

Options: metres (default)
feet

Description: Selects which units the sensor will use to report the measured depth.

12P – Depth at 4 mA

Range: 0 – 1000 **Default:** 0

Description: Calibrates the soft starter to the 4 mA (0%) level of the depth sensor input.

12Q – Depth at 20 mA

Range: 0 – 1000 **Default:** 0

Description: Calibrates the soft starter to the 20 mA (100%) level of the depth sensor input.

9.15 13 Flow Protection**NOTE**

The parameters in this group are only active if a smart card is installed.

Flow protection uses terminals B33, B34 or C23, C24 on the smart card.

13A – High Flow Trip Level

Range: 0 – 5000 **Default:** 0

Description: Sets the trip point for high flow protection.

13B – Low Flow Trip Level

Range: 1 – 5000 **Default:** 5

Description: Sets the trip point for low flow protection.

13C – Flow Start Delay

Range: 00:00:50 - 30:00:00 mm:ss:ms **Default:** 0.5 seconds

Description: Sets a delay before a flow protection trip can occur. The delay is counted from the time a start signal is received. The flow level is ignored until the start delay has elapsed.

13D – Flow Response Delay

Range: 00:00:10 - 30:00:00 mm:ss:ms **Default:** 0.5 seconds

Description: Sets a delay between the flow passing the high or low flow trip levels, and the soft starter tripping.

9.16 14 Pressure Protection



NOTE

The parameters in this group are only active if a smart card is installed.

Pressure protection uses terminals B23, B24 or C33, C34, C43, C44 on the smart card.

14A – High Pressure Trip Level

Range: 0 – 5000 **Default:** 10

Description: Sets the trip point for high pressure protection.

14B – High Pressure Start Delay

Range: 00:00:10 – 30:00:00 mm:ss:ms **Default:** 0.5 seconds

Description: Sets a delay before a high pressure protection trip can occur. The delay is counted from the time a start signal is received. The pressure is ignored until the start delay has elapsed.

14C – High Pressure Response Delay

Range: 00:00:10 – 30:00:00 mm:ss:ms **Default:** 0.5 seconds

Description: Sets a delay between the pressure passing the high pressure trip level, and the soft starter tripping.

14D – Low Pressure Trip Level

Range: 0 – 5000 **Default:** 5

Description: Sets the trip point for high pressure protection.

14E – Low Pressure Start Delay

Range: 00:00:10 – 30:00:00 mm:ss:ms **Default:** 0.5 seconds

Description: Sets a delay before a low pressure protection trip can occur. The delay is counted from the time a start signal is received. The pressure is ignored until the start delay has elapsed.

14F – Low Pressure Response Delay

Range: 00:00:10 – 30:00:00 mm:ss:ms **Default:** 0.5 seconds

Description: Sets a delay between the pressure passing the low pressure trip level, and the soft starter tripping.

9.17 15 Pressure Control

Pressure control use terminals B23, B24 on the smart card.



NOTE

The parameters in this group are only active if a smart card is installed.

15A – Pressure Control Mode

Options:	Off (default)	The WSB will not use the pressure sensor to control soft starting.
	Falling Pressure Start	The WSB will start when the pressure drops below the level selected in parameter 15B <i>Start Pressure Level</i> .
	Rising Pressure Start	The WSB will start when the pressure rises above the level selected in parameter 15B <i>Start Pressure Level</i> .

Description: Selects how the WSB will use data from the pressure sensor to control the motor.

15B – Start Pressure Level

Range: 1 – 5000 **Default:** 5

Description: Sets the pressure level to trigger the WSB to perform a soft start.

15C – Start Response Delay

Range: 00:00:10 – 30:00:00 mm:ss:ms **Default:** 0.5 seconds

Description: Sets a delay between the pressure passing the pressure control start level, and the WSB performing a soft start.

15D – Stop Pressure Level

Range: 0 – 5000 **Default:** 10

Description: Sets the pressure level to trigger the WSB to stop the motor.

15E – Stop Response Delay

Range: 00:00:10 – 30:00:00 mm:ss:ms **Default:** 0.5 seconds

Description: Sets a delay between the pressure passing the pressure control stop level, and the WSB stopping the motor.

9.18 16 Depth Protection



NOTE

The parameters in this group are only active if a smart card is installed.

Depth protection uses terminals B13, B14 or C13, C14 on the smart card.

16A – Depth Trip Level

Range: 0 – 1000 **Default:** 5

Description: Sets the trip point for depth protection.

16B – Depth Reset Level

Range: 0 – 1000 **Default:** 10

Description: Sets the level for the WSB to auto-reset a depth trip.

16C – Depth Start Delay

Range: 00:00:10 – 30:00:00 mm:ss:ms **Default:** 0.5 seconds

Description: Sets a delay before a depth protection trip can occur. The delay is counted from the time a start signal is received. The depth input is ignored until the start delay has elapsed.

16D – Depth Response Delay

Range: 00:00:10 – 30:00:00 mm:ss:ms **Default:** 0.5 seconds

Description: Sets a delay between the depth passing the depth protection trip level, and the soft starter tripping.

9.19 17 Thermal Protection



NOTE

The parameters in this group are only active if a smart card is installed.

17A – Temperature Sensor Type

Options: None (default)
PT100

Description: Selects which type of sensor is associated with the temperature sensor input on the smart card.

17B – Temperature Trip Level

Range: 0° – 240° **Default:** 40°

Description: Sets the trip point for temperature protection. Use parameter 10B *Temperature Scale* to configure the temperature scale.

9.20 20 Advanced

20A – Tracking Gain

Range: 1% - 200%

Default: 50%

Description: Fine-tunes the behaviour of the adaptive control algorithm.

20B – Pedestal Detect

Range: 0% - 200%

Default: 80%

Description: Adjusts the behaviour of the adaptive control algorithm for soft stop.

20C – Bypass Contactor Delay

Range: 100 – 2000 milliseconds

Default: 150 milliseconds

Description: Sets the starter to match the bypass contactor closing/opening time. Set according to the specifications of the bypass contactor used. If this time is too short, the starter will trip.

20D – Model Rating

Range: 0020 ~ 0580

Default: Model dependent

Description: The soft starter's internal model reference, as shown on the silver label on the side of the unit (**1**).

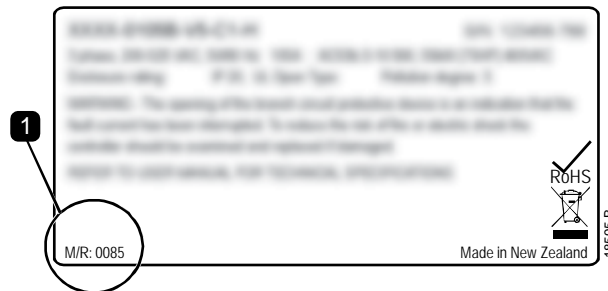

NOTE

This parameter can only be adjusted by authorised servicing agents.

20E – Screen Timeout

Options: 1 minute (default)
2 minutes
3 minutes

4 minutes
5 minutes

Description: Sets the timeout for the menu to automatically close if no keypad activity is detected.

10 Application Examples

10.1 Smart Card - Pump Protection

The WSB smart card is ideal for applications with extensive external inputs, such as pumping situations where external sensors provide additional protection to the pump and motor.

In this example, the soft starter controls a bore pump. The pump is manually started and stopped using the digital control inputs. Three 4-20 mA transducers are used to monitor water depth, pipe pressure and flow.

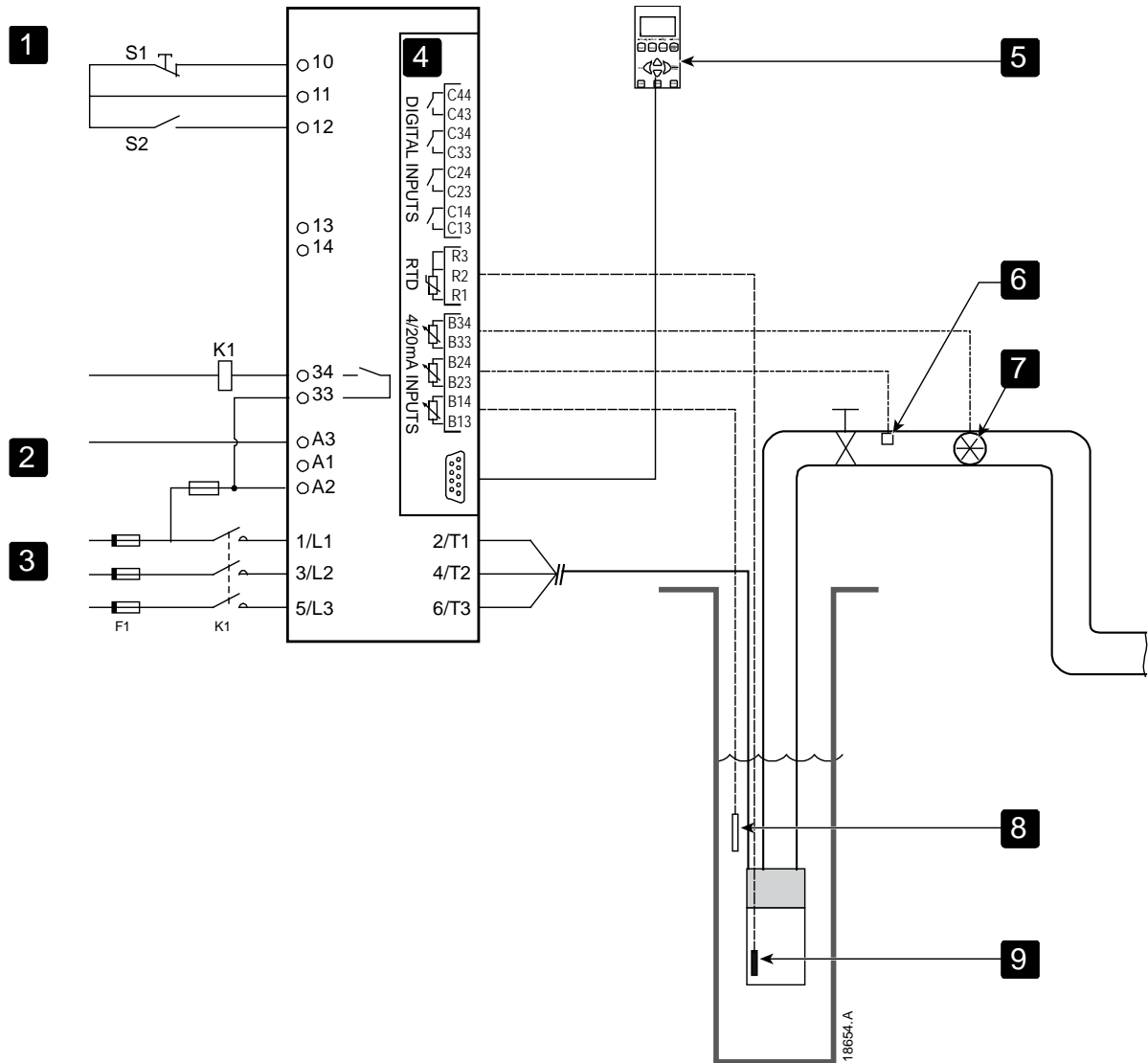

1	Digital inputs
2	Control voltage
3	Three-phase supply
4	Smart card
5	Remote keypad (optional)
6	Pressure sensor
7	Flow sensor
8	Depth sensor
9	Temperature sensor

10, 11	Reset input (S1)
11, 12	Start/stop input (S2)
33, 34	Main contactor output
R1, R2, R3	Motor temperature protection
B33, B34	Flow protection
B23, B24	Pressure protection
B13, B14	Depth protection
K1	Main contactor

Parameter settings:

- Parameter 1A *Command Source*: select 'Digital Input'.
- Parameters 12A~12Q Pump Input Configuration: Set as required.
- Parameters 13A~13D Flow Protection: Set as required.
- Parameters 14A~14F Pressure Protection: Set as required.
- Parameters 16A~16D Depth Protection: Set as required.
- Parameters 17A~17B Thermal Protection: Set as required.

10.2 Smart Card - Level Controlled Pump Activation

The WSB smart card can be used to control start/stop activation of the starter, based on information from external inputs.

In this example, the WSB controls a pump which fills a tank, with maximum and minimum water levels. A pressure sensor is used to monitor the level of water in the tank and trigger the pump to fill the tank when water drops below the minimum level, and shut off the pump when the maximum water level is reached.

A three-way selector switch allows the user to override sensor-based control, and manually start or stop the motor.

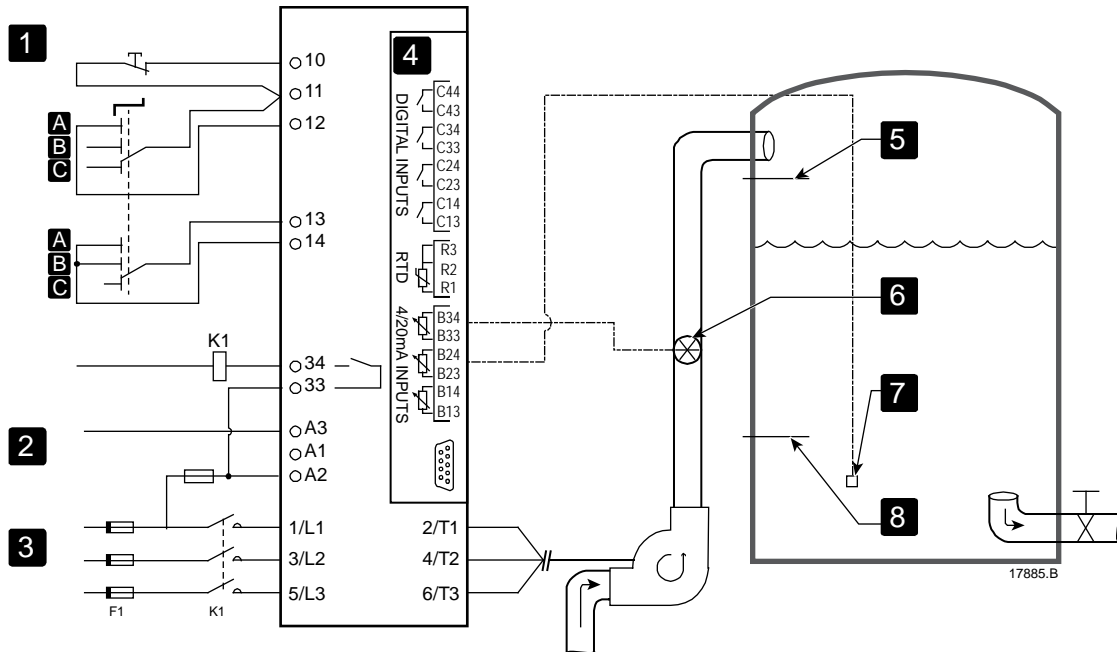

1	Digital inputs
A	Manual start
B	Manual stop
C	Automatic operation (level-controlled)
2	Control voltage
3	Three-phase supply
4	Smart card
5	Maximum water level
6	Flow sensor
7	Pressure sensor
8	Minimum water level

K1	Main contactor
10, 11	Reset input
11, 12	Start/stop input
13, 14	Programmable input A (set = Command Override: Digital)
33, 34	Main contactor output
B33, B34	Flow protection
B23, B24	Pressure or depth based control

Parameter settings:

- Parameter 1A *Command Source*: select 'Smart Card'.
- Parameter 7A *Input A Function*: select 'Command Override: Digital'.
- Parameters 12A~12Q *Pump Input Configuration*: Set as required.
- Parameters 13A~13D *Flow Protection*: Set as required.
- Parameters 15A~15E *Pressure Control*: Set as required.

11 Troubleshooting

11.1 Protection Responses

When a protection condition is detected, the WSB will write this to the event log and may also trip or issue a warning. The soft starter's response depends on the Protection Action setting (parameter group 6).

Some protection responses cannot be adjusted by the user. These trips are usually caused by external events (such as phase loss) or by a fault within the soft starter. These trips do not have associated parameters and cannot be set to Warn or Log.

If the WSB trips you will need to identify and clear the condition that triggered the trip, then reset the soft starter before restarting. To reset the starter, press the **RESET** button on the keypad or activate the Reset remote input.

If the WSB has issued a warning, the soft starter will reset itself once the cause of the warning has been resolved.

11.2 Trip Messages

Display	Possible cause/Suggested solution
Bypass overload	This trip is not adjustable. Bypass overload protection protects the soft starter from severe operating overloads while running. The soft starter will trip if it detects overcurrent at 600% of the contactor rating. Related parameters: None
Current imbalance	Current imbalance can be caused by problems with the motor, the environment or the installation, such as: <ul style="list-style-type: none"> · An imbalance in the incoming mains voltage · A problem with the motor windings · A light load on the motor · A phase loss on input terminals L1, L2 or L3 during Run mode · An SCR that has failed open circuit. A failed SCR can only be definitely diagnosed by replacing the SCR and checking the starter's performance. Related parameters: 5A, 5B, 6A
Current Read Err Lx	Where 'X' is 1, 2 or 3. Internal fault (PCB fault). The output from the CT circuit is not close enough to zero when the SCRs are turned off. Contact your local supplier for advice. Related parameters: None
Depth Sensor	The smart card has detected a fault with the depth sensor. Related parameters: 6N, 12N
EEPROM fail	An error occurred loading data from the EEPROM to RAM when the keypad powered up. If the problem persists, contact your local distributor. Related parameters: None

Display	Possible cause/Suggested solution
Excess start time	<p>Excess start time trip can occur in the following conditions:</p> <ul style="list-style-type: none"> · parameter 1B <i>Motor Full Load Current</i> is not appropriate for the motor · parameter 2D <i>Current Limit</i> has been set too low · parameter 2B <i>Start Ramp Time</i> has been set greater than the setting for 5G <i>Excess Start Time</i> setting · parameter 2B <i>Start Ramp Time</i> is set too short for a high inertia load when using Adaptive Control <p>Related parameters: 1B, 2B, 2D, 3B, 3D</p>
Firing Fail Px	<p>Where 'X' is phase 1, 2 or 3.</p> <p>The SCR did not fire as expected. The SCR may be faulty or there may be an internal wiring fault.</p> <p>Related parameters: None</p>
Flow Sensor	<p>The smart card has detected a fault with the flow sensor.</p> <p>Related parameters: 6M, 12G</p>
Flow Switch	<p>The flow switch sensor (smart card terminals C23, C24) has closed.</p> <p>Related parameters: 6S, 12G</p>
Frequency	<p>This trip is not adjustable.</p> <p>The mains frequency has gone beyond the specified range. Check for other equipment in the area that could be affecting the mains supply, particularly variable speed drives and switch mode power supplies (SMPS).</p> <p>If the WSB is connected to a generator set supply, the generator may be too small or could have a speed regulation problem.</p> <p>Related parameters: 6I</p>
Heatsink overtemperature	<ul style="list-style-type: none"> · Check that bypass contactors are operating. · Check that cooling fans are operating (models WSB-0064BP~WSB-0580BP). · If mounted in an enclosure, check if ventilation is adequate. · The WSB must be mounted vertically. <p>Related parameters: None</p>
High Flow	<p>The flow sensor connected to the smart card has activated high flow protection.</p> <p>Related parameters: 6Q, 12G, 12I, 12J, 13A, 13C, 13D</p>
High Pressure	<p>The pressure sensor connected to the smart card has activated high pressure protection.</p> <p>Related parameters: 6O, 12C, 12E, 12F, 14A, 14B, 14C</p>
Input A trip Input B trip	<p>The soft starter's programmable input is set to a trip function and has activated. Resolve the trigger condition.</p> <p>Related parameters: 7A, 7B, 7C, 7D, 7E, 7F, 7G, 7H</p>

Display	Possible cause/Suggested solution
Instantaneous overcurrent	<p>This trip is not adjustable.</p> <p>The current on all three phases has exceeded 7.2 times the value of parameter 1B <i>Motor Full Load Current</i>.</p> <p>Causes can include a locked rotor condition or an electrical fault in the motor or cabling.</p> <p>Related parameters: None</p>
Internal fault x	<p>Where 'X' is a number.</p> <p>This trip is not adjustable.</p> <p>The WSB has tripped on an internal fault. Contact your local supplier with the fault code (X).</p>
Keypad disconnected	<p>Parameter 1A <i>Command Source</i> is set to Remote Keypad but the WSB cannot detect a remote keypad.</p> <p>If a remote keypad is installed, check the cable is firmly connected to the soft starter.</p> <p>If no remote keypad is installed, change the setting of parameter 1A.</p> <p>Related parameters: 1A</p>
L1 phase loss L2 phase loss L3 phase loss	<p>This trip is not adjustable.</p> <p>During pre-start checks the starter has detected a phase loss as indicated.</p> <p>In run state, the starter has detected that the current on the affected phase has dropped below 2% of the programmed motor FLC for more than 1 second, indicating that either the incoming phase or connection to the motor has been lost.</p> <p>Check the supply and the input and output connections at the starter and at the motor end.</p> <p>Related parameters: None</p>
L1-T1 shorted L2-T2 shorted L3-T3 shorted	<p>During pre-start checks the starter has detected a shorted SCR or a short within the bypass contactor as indicated. Consider using PowerThrough to allow operation until the starter can be repaired.</p> <p>Related parameters: 6L</p>
Low Control Volts	<p>The WSB has detected a drop in the internal control voltage.</p> <ul style="list-style-type: none"> · Check the external control supply (A1, A2, A3) and reset the starter. <p>If the external control supply is stable:</p> <ul style="list-style-type: none"> · the 24 V supply on the main control PCB may be faulty; or · the bypass driver PCB may be faulty. Contact your local supplier for advice. <p>This protection is not active in Ready state.</p> <p>Related parameters: None</p>
Low Flow	<p>The flow sensor connected to the smart card has activated low flow protection.</p> <p>Related parameters: 6R, 12G, 12I, 12J, 13B, 13C, 13D</p>

Display	Possible cause/Suggested solution
Low Pressure	<p>The pressure sensor connected to the smart card has activated low pressure protection. Related parameters: 6P, 12C, 12E, 12F, 14D, 14E, 14F</p>
Low Water	<p>The depth sensor connected to the smart card has activated depth protection. Related parameters: 6T, 12N, 12P, 12Q, 16A, 16B, 16C</p>
Motor overload	<p>The motor has reached its maximum thermal capacity. Overload can be caused by:</p> <ul style="list-style-type: none"> · The soft starter protection settings not matching the motor thermal capacity · Excessive starts per hour or start duration · Excessive current · Damage to the motor windings <p>Resolve the cause of the overload and allow the motor to cool. Related parameters: 1B, 1C, 1D, 1E, 5G, 6D</p> <p> NOTE Parameters 1C, 1D and 1E determine the trip current for motor overload protection. The default settings of parameters 1C, 1D and 1E provide Motor Overload Protection: Class 10, Trip Current 105% of FLA (full load amperage) or equivalent.</p>
Motor Connection Tx	<p>Where 'X' is 1, 2 or 3. The motor is not connected correctly to the soft starter.</p> <ul style="list-style-type: none"> · Check individual motor connections to the soft starter for power circuit continuity. · Check connections at the motor terminal box. <p>This trip is not adjustable. Related parameters: None</p>
Motor thermistor	<p>The motor thermistor input has been enabled and:</p> <ul style="list-style-type: none"> · The resistance at the thermistor input has exceeded 3.6 kΩ for more than one second. · The motor winding has overheated. Identify the cause of the overheating and allow the motor to cool before restarting. · The motor thermistor input has been opened. <p>If thermistors have previously been connected to the WSB but are no longer required, use the Thermistor Reset function to disable the thermistor. Related parameters: 6J</p>
Network communication	<p>There is a network communication problem, or the network master may have sent a trip command to the starter. Check the network for causes of communication inactivity. Related parameters: 6G</p>

Display	Possible cause/Suggested solution
Not ready	<ul style="list-style-type: none"> • The reset input may be active. If the reset input is active, the starter will not operate. • The soft starter may be waiting for the restart delay to elapse. The length of the restart delay is controlled by parameter 5H <i>Restart Delay</i>. <p>Related parameters: 5H</p>
Overcurrent	<p>The current has exceeded the level set in parameter 5E <i>Overcurrent</i> for longer than the time set in parameter 5F <i>Overcurrent Delay</i>. Causes can include a momentary overload condition.</p> <p>Related parameters: 5E, 5F, 6C</p>
Parameter out of range	<p>This trip is not adjustable.</p> <ul style="list-style-type: none"> • A parameter value is outside the valid range. The keypad will indicate the first invalid parameter. • An error occurred loading data from the EEPROM to RAM when the keypad powered up. • The parameter set or values in the keypad do not match the parameters in the starter. • "Load User Set" has been selected but no saved file is available. <p>Reset the fault. The starter will load the default settings. If the problem persists, contact your local distributor.</p> <p>Related parameters: None</p>
Phase sequence	<p>Mains voltage must be connected to the soft starter's input terminals (L1, L2, L3) in positive phase sequence. Check the phase sequence on L1, L2, L3.</p> <p>Related parameters: None</p>
Power loss	<p>This trip is not adjustable.</p> <p>The starter is not receiving mains supply on one or more phases when a Start Command is given.</p> <p>Check that the main contactor closes when a start command is given, and remains closed until the end of a soft stop. Check the fuses. If testing the soft starter with a small motor, it must draw at least 2% of its minimum FLC setting on each phase.</p> <p>Related parameters: None</p>
Pressure Sensor	<p>The smart card has detected a fault with the pressure sensor.</p> <p>Related parameters: 6L, 12C</p>
Rating Capacity	<p>The WSB is operating beyond its safe capacity. Allow the starter to cool.</p> <p>Related parameters: None</p>
RTD Circuit	<p>The RTD input on the smart card is open circuit or short circuit.</p> <p>Related parameters: 6U, 17B</p>

Display	Possible cause/Suggested solution
SCR Itsm	The SCR current surge rating has been exceeded. Related parameters: None
SCR overtemperature	The temperature of the SCRs, calculated by the thermal model, is too high to allow further operation. Wait for the starter to cool. Related parameters: None
Starter communication	There is a problem with the connection between the soft starter and the optional expansion card. Remove and reinstall the card. If the problem persists, contact your local distributor. Related parameters: 6G
Thermistor circuit	The thermistor input has been enabled and: <ul style="list-style-type: none"> · The resistance at the input has fallen below 20 Ω (the cold resistance of most thermistors will be over this value) or · A short circuit has occurred. Check and resolve this condition. Related parameters: None
Time-overcurrent	The WSB is internally bypassed and has drawn high current during running. (The 10A protection curve trip has been reached or the motor current has risen to 600% of the motor FLC setting.) Related parameters: None
Undercurrent	The motor has experienced a sharp drop in current, caused by loss of load. Causes can include broken components (shafts, belts or couplings), or a pump running dry. Related parameters: 5C, 5D, 6B
VZC Fail Px	Where 'X' is 1, 2 or 3. Internal fault (PCB fault). Contact your local supplier for advice. Related parameters: None

11.3 General Faults

This table describes situations where the soft starter does not operate as expected but does not trip or give a warning.

Symptom	Probable Cause
Starter "Not Ready"	<ul style="list-style-type: none"> The reset input may be active. If the reset input is active, the starter will not operate.
The soft starter does not respond to the START or RESET button on the keypad.	<ul style="list-style-type: none"> The soft starter will only accept commands from the keypad if parameter 1A <i>Command Source</i> is set to Remote Keypad. Check that the Local LED on the starter is on.
The soft starter does not respond to commands from the control inputs.	<ul style="list-style-type: none"> The soft starter will only accept commands from the inputs if parameter 1A <i>Command Source</i> is set to Digital Input. Check the setting of 1A. The control wiring may be incorrect. Check that the remote start, stop and reset inputs are configured correctly (refer to <i>Start/Stop</i> on page 25 for details). The signals to the remote inputs may be incorrect. Test the signalling by activating each input signal in turn.
The soft starter does not respond to a start command from either the keypad or the digital inputs.	<ul style="list-style-type: none"> The soft starter may be waiting for the restart delay to elapse. The length of the restart delay is controlled by parameter 5H <i>Restart Delay</i>. The motor may be too hot to permit a start. The soft starter will only permit a start when it calculates that the motor has sufficient thermal capacity to complete the start successfully. Wait for the motor to cool before attempting another start. The reset input may be active. If the reset input is active, the starter will not operate. The soft starter may be waiting for control signals via the communications network (parameter 1A <i>Command Source</i> = Network).
Remote keypad shows message "awaiting data"	The keypad is not receiving data from the control PCB. Check the cable connection.
The soft starter does not control the motor correctly during starting.	<ul style="list-style-type: none"> Start performance may be unstable when using a low <i>Motor Full Load Current</i> setting (parameter 1B). Power factor correction (PFC) capacitors must be installed on the supply side of the soft starter and must be disconnected during starting and stopping. To use the WSB to control power factor correction, connect the PFC contactor to a programmable relay set to Run. High levels of harmonics on the mains supply can affect soft starter performance. If variable speed drives are installed nearby, check they are properly grounded and filtered.

Symptom	Probable Cause
<p>Motor does not reach full speed.</p>	<ul style="list-style-type: none"> · If the start current is too low, the motor will not produce enough torque to accelerate to full speed. The soft starter may trip on excess start time. <p> NOTE Make sure the motor starting parameters are appropriate for the application and that you are using the intended motor starting profile. If a programmable input is set to Motor Set Select, check that the corresponding input is in the expected state.</p> <ul style="list-style-type: none"> · The load may be jammed. Check the load for severe overloading or a locked rotor situation.
<p>Soft stop ends too quickly.</p>	<ul style="list-style-type: none"> · The soft stop settings may not be appropriate for the motor and load. Review the soft stop settings. · If the motor is very lightly loaded, soft stop will have limited effect.
<p>After selecting Adaptive Control the motor used an ordinary start and/or the second start was different to the first.</p>	<ul style="list-style-type: none"> · The first Adaptive Control start is actually 'Constant Current' so that the starter can learn from the motor characteristics. Subsequent starts use Adaptive Control.
<p>Parameter settings cannot be stored.</p>	<ul style="list-style-type: none"> · Make sure you are saving the new value by pressing the ENTER button after adjusting a parameter setting. If you press EXIT, the change will not be saved. The WSB does not display a confirmation. · Check that the adjustment lock (parameter 10G) is set to Read & Write. If the adjustment lock is set to Read Only, settings can be viewed but not changed.
<p>USB Full</p>	<ul style="list-style-type: none"> · The USB drive may not have enough free space available for the selected function. · The file system on the USB drive may not be compatible with the soft starter. WSB supports FAT32 file systems. WSB USB functions are not compatible with NTFS file systems.
<p>USB Missing</p>	<p>A USB function has been selected in the menu, but the product cannot detect a USB drive. Check that the USB drive has been inserted in the port.</p>
<p>File Missing</p>	<p>A USB function has been selected in the menu, but the required file cannot be found.</p> <p>Save/Load Master Parameters uses a file called Master_Parameters.par, at the top level of the USB drive. For these functions to work correctly, do not move or rename this file.</p>

Symptom	Probable Cause
File Not Valid	A USB function has been selected in the menu, but the file is not valid.
File Empty	A USB function has been selected in the menu and the file has been found, but does not contain the expected content.
Rating Not Valid	The value selected for parameter 20D <i>Model Rating</i> does not match the soft starter. Set parameter 20D to match the rating shown on the WSB nameplate label (on the side of the unit).

