



INSTRUCTIONS

PROFINET MODULE

for use with WSIQ2/WSE

WorldWide Electric Corporation
Phone: 1-800-808-2131
Fax: 1-800-711-1616
www.worldwideelectric.net

Compatibility

The Profinet Module is compatible with the following WorldWide Electric soft starters:

- WSE – 24 VAC/VDC and 110/240 VAC control voltage.
The Profinet Module is not suitable for use with WSE starters using 380/440 VAC control voltage.
- WSIQ2 – all models.

Contents

1	Important User Information	1
2	Warnings.....	1
3	Installation	2
4	Connection	3
5	Device Configuration	5
6	Operation	6
7	Packet Structures.....	7
8	Network Design	14
9	Specifications	16

1 Important User Information

1.1 Product Design

The Profinet Module allows the soft starter to connect to an Ethernet network and be controlled or monitored using an Ethernet communication model.

The Profinet Module operates at the application layer.

Familiarity with Ethernet protocols and networks is required to operate the device successfully. For difficulties using this device with third party products, including PLCs, scanners and commissioning tools, contact the relevant supplier.

1.2 Safety

It is the installer's responsibility to follow all instructions in this manual and to follow correct electrical practice.

Close attention is required to the electrical installation and the system design to avoid hazards either in normal operation or in the event of equipment malfunction. System design, installation, commissioning and maintenance must be carried out by personnel who have the necessary training and experience. They must read this safety information and this guide carefully.

1.3 Disclaimer

The examples and diagrams in this manual are included solely for illustrative purposes. The information contained in this manual is subject to change at any time and without prior notice. In no event will responsibility or liability be accepted for direct, indirect or consequential damages resulting from the use or application of this equipment.

2 Warnings



WARNING

For your safety, isolate the soft starter completely from mains voltage before attaching or removing accessories.



WARNING

Observe all necessary safety precautions when controlling the soft starter remotely. Alert personnel that machinery may start without warning.

3 Installation



CAUTION

Remove mains and control voltage from the soft starter before attaching or removing accessories. Failure to do so may damage the equipment.

3.1 Installation Procedure

1. Remove control power and mains supply from the soft starter.
2. Fully pull out the top and bottom retaining clips on the module. [A]
3. Line up the module with the comms port slot. [B]
4. Push in the top and bottom retaining clips to secure the module to the starter. [C]
5. Connect Ethernet Port 1 or Port 2 on the Profinet Module to the network.
6. Apply control power to the soft starter.

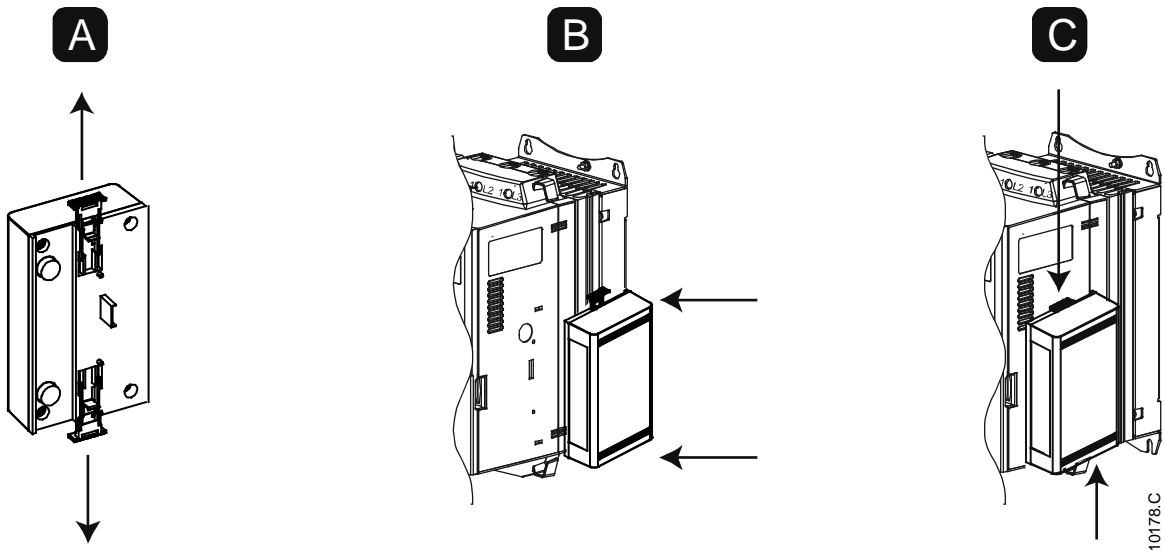

To remove the module:

1. Remove control power and mains supply from the soft starter.
2. Disconnect all external wiring from the module.
3. Fully pull out the top and bottom retaining clips on the module. [A]
4. Pull the module away from the soft starter.

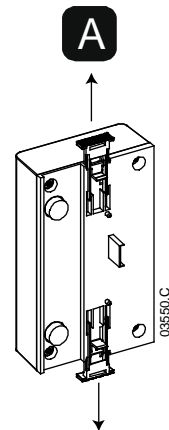

4 Connection

4.1 Soft Starter Connection

The device is powered from the soft starter.

The Profinet Module is not suitable for use with WSE starters using 380/440 VAC control voltage.

WSE		WSIQ2	
1	Soft starter A1, 02: Stop input	1	Soft starter (remote mode) C31, C32: Stop input C41, C42: Reset input
2	Profinet Module	2	Profinet Module
3	RJ45 Ethernet ports	3	RJ45 Ethernet ports

WSE:

- For the soft starter to accept fieldbus commands, a link must be fitted across terminals A1-02 on the starter.

WSIQ2:

- Control via the fieldbus communication network is always enabled in local control mode, and can be enabled or disabled in remote control mode (parameter 6R *Comms in Remote*). Refer to the soft starter user manual for parameter details.
- Input links are required across the stop and reset inputs if the soft starter is being operated in Remote mode. In Local mode, links are not required.

4.2 Network Connection

Ethernet Ports

The device has two Ethernet ports. If only one connection is required, either port can be used.

Cables

Use Category 5, 5e, 6 or 6e cable to connect to the device.

EMC Precautions

To minimise electromagnetic interference, Ethernet cables should be separated from motor and mains cables by 200 mm.

If the Ethernet cable must cross motor or mains cables, the crossing should be at an angle of 90°.

4.3 Network Establishment

The controller must establish communications directly with each device before the device can participate in the network.

4.4 Addressing

Each device in a network is addressed using a MAC address and a device name. The MAC address is fixed within the device and is printed on a label on the front of the device.

5 Device Configuration

To permanently configure attributes in the Profinet Module, use the Ethernet Device Configuration Tool and untick "Store settings temporary".



NOTE

The Error LED is on if the device is not configured. If the device is configured but is not passing I/O data, the Error LED will flash. The Error LED will be active during the configuration process.

5.1 Ethernet Device Configuration Tool

The Ethernet Device Configuration Tool is available from your local supplier.

To configure the device using the Ethernet Device Configuration Tool:

1. Attach the module to the soft starter.
2. Connect Ethernet Port 1 or Port 2 on the Profinet Module to the network.
3. Apply control power to the soft starter.
4. Start the Ethernet Device Configuration Tool.
5. In Options > Protocols, select DCP and deselect NetIdent.

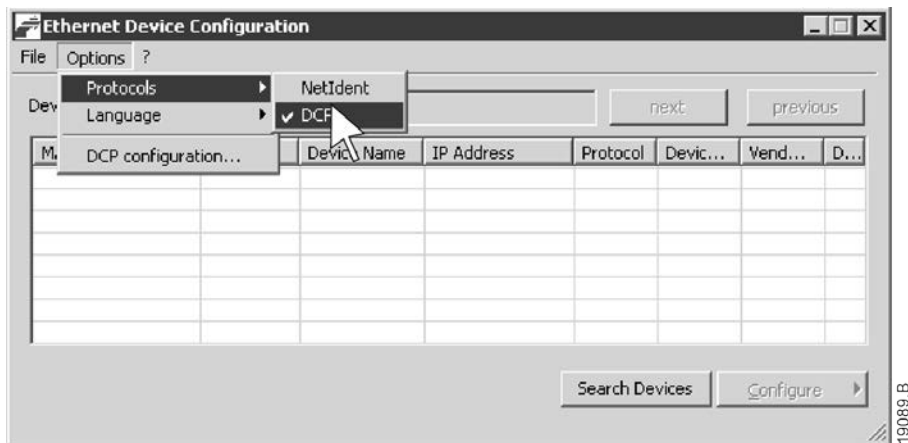

6. Click on Search Devices. The software will search for connected devices.

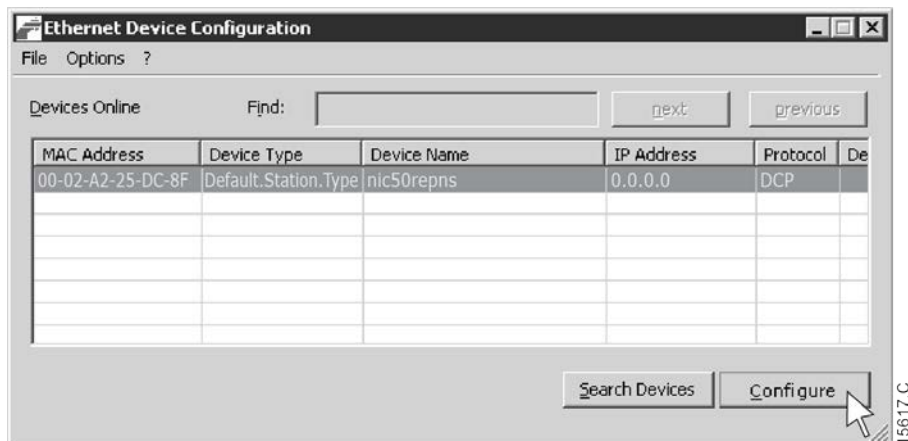

7. To configure a device name, click Configure then select Device Name.

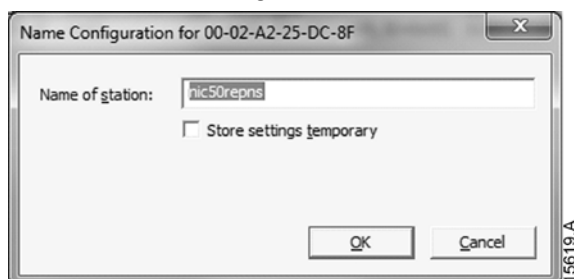

6 Operation

The device has been designed for use in a system complying with the Profinet standard. For successful operation, the controller must also support all functions and interfaces described in this document.

6.1 Device Classification

The Profinet Module is a Profinet IO-Device and must be managed by an IO-Controller over Ethernet.

6.2 Master Configuration

Import the latest GSDML file into your Master configuration tool. This file is available from your supplier.

If your Master uses on-screen icons, two graphic bitmap files are available from the website. SSPM_N.bmp indicates normal mode. SSPM_D.bmp indicates diagnostic mode.

6.3 Feedback LEDs

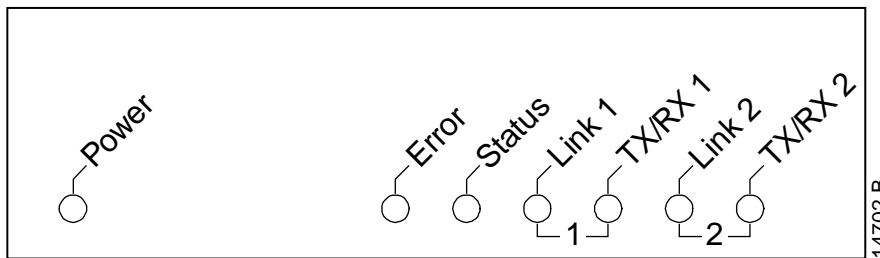

LED name	LED Status	Description
Power	Off	Device is not powered up.
	On	Device is receiving power.
Error	Off	No error.
	Flashing	Connection not established.
	On	No physical link or slow physical link. No configuration.
Status	Off	No error.
	Flashing	DCP signal service initiated via the bus.
Link x	Off	No network connection.
	On	Connected to a network.
TX/RX x	Flashing	Transmitting or receiving data.

7 Packet Structures



NOTE

Some soft starters do not support some functions.

7.1 Ensuring Safe and Successful Control

Data written to the device will remain in its registers until the data is overwritten or the device is reinitialised. The device will not transfer successive duplicate commands to the soft starter.

- If the soft starter is started via fieldbus communications but stopped via the keypad or a remote input, an identical start command cannot be used to restart the starter.
- If the soft starter may also be controlled via the keypad or the remote inputs (as well as via fieldbus communications), a control command should be immediately followed by a status query to confirm the command has been actioned.

7.2 Control commands (controller to device)

Use output bytes 0-1 to send a control command to the soft starter.

Byte	Bits	Details
0	0 to 1	<i>Reserved</i>
	2 to 3	0 = Use soft starter remote input to select motor set 1 = Use primary motor set when starting 2 = Use secondary motor set when starting 3 = <i>Reserved</i>
	4	0 = stop action will be as selected in the soft starter 1 = stop action will be a coast to stop
	5 to 7	<i>Reserved</i>
1	0	0 = Stop 1 = Start
	1 to 2	<i>Reserved</i>
	3	1 = Reset
	4 to 7	<i>Reserved</i>
2 to 5		Parameter management (refer to <i>Parameter Management</i> on page 11)



NOTE

Bit 4 of byte 0 must be set to 0 before the soft starter can perform a start.

7.3 Status information (device to controller)

Starter status information is always available when the device is active.

For models WSIQ2-0053BP and smaller, current reported via communications is 10 times greater than the actual value (displayed on the keypad).

Bytes 0-1: Control status

Bits	Details
0 to 5	Current (% motor FLC)
6	Local/Remote 0 = Remote control (Network) 1 = Local control (Keypad, Digital Input)
7	1 = Ramping (starting or stopping)
8	1 = Ready
9	1 = Starting, running or stopping
10	1 = Tripped
11	1 = Warning
12 to 15	<i>Reserved</i>

Motor current (% FLC) represents current as a percentage of the set motor full load current. A maximum value of 63 represents 200% full load current. To convert this value to a readable percentage, divide by 0.315.

Bytes 2-3: Starter state

Bits	Details
0 to 3	The decimal value of bits 0~3 indicates the starter's state: 0 = Communication error between device and soft starter 1 = Ready 2 = Starting 3 = Running 4 = Stopping 5 = Not ready (restart delay, restart temperature check) 6 = Tripped 7 = Menu open (cannot start) 8 = Jog forward 9 = Jog reverse
4	0 = Negative phase sequence 1 = Positive phase sequence
5	1 = Current exceeds FLC
6	0 = Uninitialised 1 = Initialised
7	1 = Communication error between device and soft starter
8 to 15	<i>Reserved</i>

Bytes 4-5: Trip code

Bits	Details
0 to 15	Refer to <i>Trip Codes</i> on page 12

Bytes 6-7: Motor current

Bits	Details
0 to 15	Average rms current across all three phases

Bytes 8-9: Motor temperature

Bits	Details
0 to 15	Motor 1 thermal model (%)

Bytes 10-117: Extended information

Bytes 10~117 report information from the soft starter's internal registers.

Byte	Description	Bits	Details	
10-11	Version	0 to 5	<i>Reserved</i>	
		6 to 8	Product parameter list version	
		9 to 15	Product type code: 4 = WSE 6 = WSIQ2	
12-13	Device details	0 to 7	<i>Reserved</i>	
		8 to 15	Soft starter model ID	
14-15	<i>Reserved</i>			
16-17	<i>Reserved</i>			
18-19	Starter state	0 to 4	0 = <i>Reserved</i> 1 = Ready 2 = Starting 3 = Running 4 = Stopping 5 = Not ready (restart delay, restart temperature check) 6 = Tripped 7 = Programming mode 8 = Jog forward 9 = Jog reverse	
			5	1 = Warning
			6	0 = Uninitialised 1 = Initialised
			7	0 = Remote control (Network) 1 = Local control (Keypad, Digital Input)
			8	<i>Reserved</i>
			9	0 = Negative phase sequence 1 = Positive phase sequence
			10 to 15	Refer to <i>Trip Codes</i> on page 12
			20-21	Current
14 to 15	<i>Reserved</i>			
22-23	Current	0 to 9	Current (% motor FLC)	
		10 to 15	<i>Reserved</i>	

Byte	Description	Bits	Details
24-25	Motor temperature	0 to 7	Motor 1 thermal model (%)
		8 to 15	<i>Reserved</i>
26-27	Power	0 to 11	Power
		12 to 13	Power scale 0 = Multiply power by 10 to get W 1 = Multiply power by 100 to get W 2 = Power (kW) 3 = Multiply power by 10 to get kW
		14 to 15	<i>Reserved</i>
28-29	% Power factor	0 to 7	100% = power factor of 1
		8 to 15	<i>Reserved</i>
30-31	<i>Reserved</i>		
32-33	Current	0 to 13	Phase 1 current (rms)
		14 to 15	<i>Reserved</i>
34-35	Current	0 to 13	Phase 2 current (rms)
		14 to 15	<i>Reserved</i>
36-37	Current	0 to 13	Phase 3 current (rms)
		14 to 15	<i>Reserved</i>
38-39	<i>Reserved</i>		
40-41	<i>Reserved</i>		
42-43	<i>Reserved</i>		
44-45	Parameter list version number	0 to 7	Parameter list minor revision
		8 to 15	Parameter list major version
46-47	Digital input state		For all inputs, 0 = open, 1 = closed (shorted)
		0	Start
		1	Stop
		2	Reset (Refer to note)
		3	Input A
4 to 15	<i>Reserved</i>		
48-49	Trip code	0 to 15	Refer to <i>Trip Codes</i> on page 12
50-113	<i>Reserved</i>		
114-117	Parameter management		Refer to <i>Parameter Management</i> on page 11



NOTE

The reset input is normally closed by default. If parameter **6M Remote Reset Logic** is set to normally open, the reported state will be inverted (0 = closed, 1 = open).

7.4 Parameter Management

Parameter Management (Read/write)

The Profinet Module can read parameter values from and write parameter values to the soft starter. The module handles one parameter at a time.

The device references parameters according to their position in the starter's parameter list.

- Parameter number 1 corresponds to parameter 1A *Motor Full Load Current*
- The WSIQ2 has 168 parameters. Parameter number 168 corresponds to parameter 20I *Pedestal Detect*.



CAUTION

Changing the values of the Factory parameters (parameter group 20) may cause unpredictable behaviour in the soft starter. Consult your local supplier before adjusting the Factory parameters.

- **Output**

Use output bytes 2-5 to read or write a parameter to the soft starter.

Master > Slave output bytes are structured as follows.

Byte	Bits	Details
2	0 to 7	Parameter number to read/write
3	0	<i>Reserved</i>
	1	1 = Read parameter
	2	1 = Write parameter
	3 to 7	<i>Reserved</i>
4	0 to 7	Low byte parameter value to write to soft starter/ zero data values for read
5	0 to 7	High byte parameter value to write to soft starter/ zero data values for read

- **Input**

Parameter data from the starter is reported in input bytes 114-117.

Slave > Master input bytes are structured as follows.

Byte	Bits	Details
114	0 to 7	Echo parameter number
115	0	1 = Invalid parameter number
	1	1 = Invalid parameter value
	2 to 7	<i>Reserved</i>
116	0 to 7	Low byte parameter value read from soft starter
117	0 to 7	High byte parameter value read from soft starter

7.5 Trip Codes

Trip Code	Description
1	Excess start time
2	Motor overload
3	Motor thermistor
4	Current imbalance
5	Frequency
6	Phase sequence
7	Instantaneous overcurrent
8	Power loss
9	Undercurrent
10	Heatsink overtemperature
11	Motor connection
12	Input A trip
13	FLC too high
14	Unsupported option (function not available in inside delta)
15	Starter communication (between device and soft starter)
16	Network communication (between device and network)
17	Internal fault
20	Ground fault
23	Parameter out of range
24	Input B trip
26	L1 phase loss
27	L2 phase loss
28	L3 phase loss
29	L1-T1 shorted
30	L2-T2 shorted
31	L3-T3 shorted
32	Motor 2 overload
33	Time-overcurrent / Bypass overload
34	SCR overtemperature
35	Battery/clock
36	Thermistor circuit
37	RTD/PT100 A
38	RTD/PT100 B
39	RTD/PT100 C
40	RTD/PT100 D
41	RTD/PT100 E
42	RTD/PT100 F
43	RTD/PT100 G
45	RTD/PT100 X Circct
46	Analog input trip
255	No trip

7.6 Examples

Control commands (controller to device)

Start the motor using parameter set 1							
Byte 0	Byte 1	Byte 2	Byte 3	Byte 4	Byte 5	Byte 6	Byte 7
4	1						

Start the motor, select via remote input							
Byte 0	Byte 1	Byte 2	Byte 3	Byte 4	Byte 5	Byte 6	Byte 7
0	1						

Stop the motor using the programmed soft stop for motor set 2							
Byte 0	Byte 1	Byte 2	Byte 3	Byte 4	Byte 5	Byte 6	Byte 7
8	0						

Quick stop the motor							
Byte 0	Byte 1	Byte 2	Byte 3	Byte 4	Byte 5	Byte 6	Byte 7
16	0						

Reset a trip							
Byte 0	Byte 1	Byte 2	Byte 3	Byte 4	Byte 5	Byte 6	Byte 7
≤ 28	8						

Status information (device to controller)

Read control status - Ready							
Byte 0	Byte 1	Byte 2	Byte 3	Byte 4	Byte 5	Byte 6	Byte 7
0	1						

Read control status - Running							
Byte 0	Byte 1	Byte 2	Byte 3	Byte 4	Byte 5	Byte 6	Byte 7
		3	0				

Read control status - Tripped, trip code 4 (Current imbalance)							
Byte 0	Byte 1	Byte 2	Byte 3	Byte 4	Byte 5	Byte 6	Byte 7
		6	0	4	0		

Parameter Management

Read parameter from WSIQ2: parameter number 12, 2H Stop Mode							
Byte 0	Byte 1	Byte 2	Byte 3	Byte 4	Byte 5	Byte 6	Byte 7
		12	2	0	0		

8 Network Design

The device supports star, line and ring topologies.

8.1 Star Topology

In a star network, all controllers and devices connect to a central network switch.

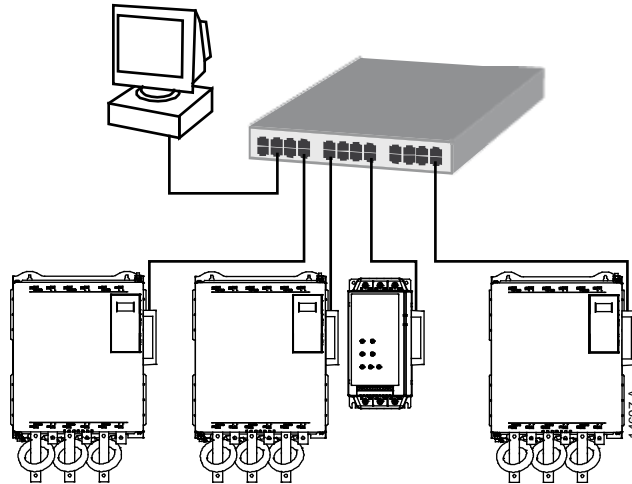

8.2 Line Topology

In a line network, the controller connects directly to one port of the first module. The second Ethernet port connects to another module, which in turn connects to another device until all devices are connected.

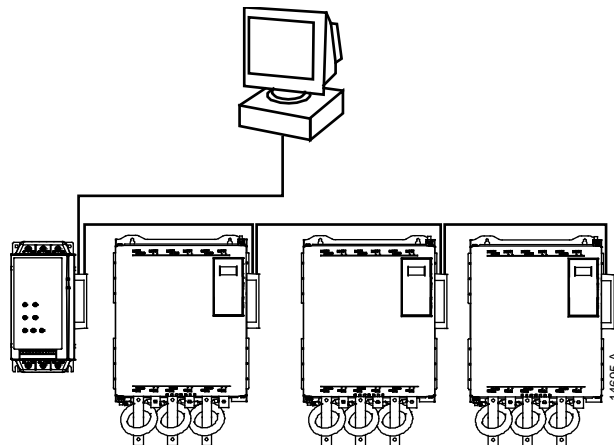

NOTE

The device has an integrated switch to allow data to pass through in line topology. The device must be receiving control power from the soft starter for the switch to operate.



NOTE

If the connection between two devices is interrupted, the controller cannot communicate with devices after the interruption point.



NOTE

Each connection adds a delay to communication with the next device. The maximum number of devices in a line network is 32. Exceeding this number may reduce the reliability of the network.

8.3 Ring Topology

In a ring topology network, the controller connects to the first module, via a network switch. The second Ethernet port of the module connects to another device, which in turn connects to another device until all devices are connected. The final device connects back to the switch.

The device supports beacon based ring node configuration.

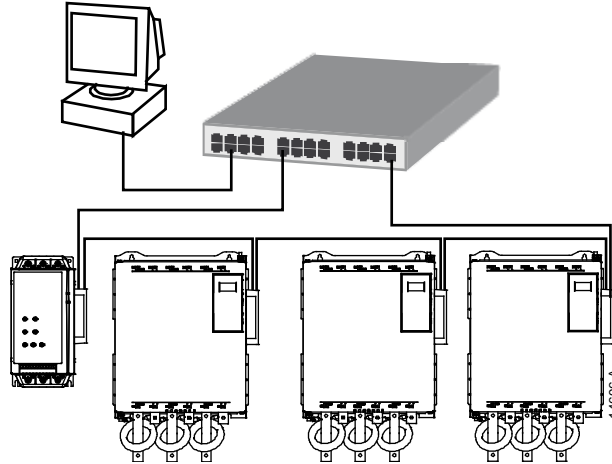

NOTE

The network switch must support loss of line detection.

8.4 Combined Topologies

A single network can include both star and line components.

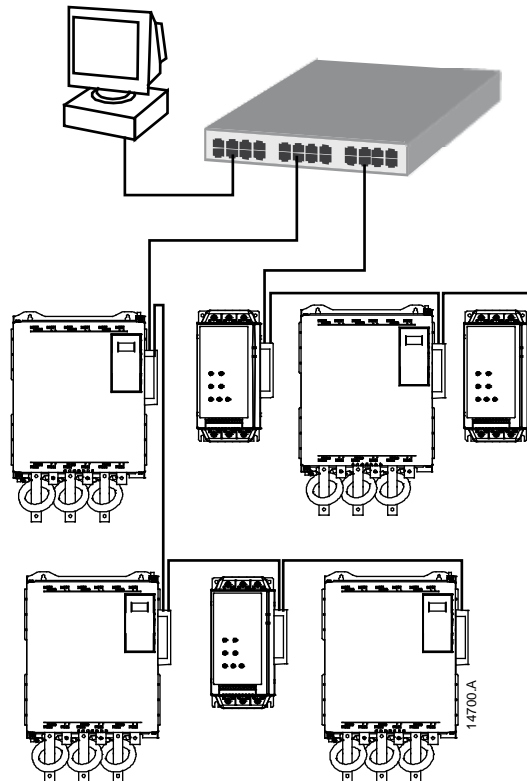

9 Specifications

- **Enclosure**

Dimensions 40 mm (W) x 166 mm (H) x 90 mm (D)

Weight 250 g

Protection IP20

- **Mounting**

Spring-action plastic mounting clips (x 2)

- **Connections**

Soft starter 6-way pin assembly

Contacts Gold flash

Network RJ45

- **Settings**

IP Address Automatically assigned

Device name Automatically assigned, configurable

- **Network**

Link speed 10 Mbps, 100 Mbps (auto-detect)

Full duplex

Auto crossover

- **Power**

Consumption (steady state, maximum) 35 mA @ 24 VDC

Reverse polarity protected

Galvanically isolated

- **Certification**

RCM IEC 60947-4-2

CE EN 60947-4-2

Profibus & Profinet International  PROFIBUS · PROFINET

