



WSIQ2 USER MANUAL



WorldWide Electric Corporation
Phone: 1-800-808-2131
Fax: 1-800-711-1616
www.worldwideelectric.net

Contents

1	About This Manual	3
2	Caution Statements.....	4
2.1	Electrical shock risk.....	4
2.2	Unexpected Operation	4
3	Avertissements à l'attention des clients canadiens.....	6
4	Introduction	8
4.1	Feature List	8
5	Basic Setup.....	9
5.1	Setup Procedure Overview	9
5.2	Testing the Installation	9
5.3	Simulation Tools.....	9
6	Installation	10
6.1	Physical Installation.....	10
6.2	Control Terminals	10
6.3	Control Voltage.....	10
6.4	Control Wiring.....	10
6.5	Relay Outputs.....	11
6.6	Motor Thermistors	11
6.7	RTD/PT100	11
6.8	Earth Terminals.....	12
6.9	Power Input and Output Configurations	12
6.10	Power Terminations	12
6.11	Schematic Diagrams	13
7	Power Circuits	14
7.1	Motor Connection	14
7.2	Bypass Contactor	16
7.3	Main Contactor	16
7.4	Circuit Breaker.....	16
7.5	Power Factor Correction	16
7.6	Short Circuit Protection Devices (SCPD)	16
7.7	UL Short Circuit Ratings	17
7.8	Fuse Selection for Type 2 Coordination	18
8	Keypad and Feedback.....	19
8.1	The Keypad	19
8.2	Starter Status LEDs.....	19
8.3	Removing and Replacing the Keypad	20
8.4	Displays.....	20
9	Maintenance Tools	22
9.1	Testing the Installation	22
9.2	Commissioning Menu (Tools).....	22
9.3	Logs Menu.....	25
10	Operation	26
10.1	Priority of Commands.....	26
10.2	Start, Stop and Reset Commands.....	26
10.3	Soft Start Methods.....	26
10.4	Stop Methods	29
10.5	Jog Operation.....	32
10.6	Inside Delta Operation.....	32
11	Programming Menu.....	33
11.1	Programming Menu	33
11.2	Adjustment Lock	33
11.3	Access Code	34
11.4	Quick Setup.....	34
11.5	Standard Menu	35
11.6	Extended Menu	36
11.7	Load/Save Settings	39
11.8	Parameter Descriptions.....	40

12	Application Examples	57
12.1	Installation with Main Contactor	57
12.2	Installation with External Bypass Contactor	58
12.3	Emergency Run Operation	59
12.4	Auxiliary Trip Circuit	60
12.5	DC Brake with External Zero Speed Sensor	62
12.6	Soft Braking	64
12.7	Two-Speed Motor	65
12.8	Slip-Ring Motor	67
13	Troubleshooting	69
13.1	Protection Responses	69
13.2	Trip Messages	69
13.3	General Faults	73
14	Appendix	75
14.1	Specifications	75
14.2	Disposal Instructions	80
14.3	Accessories	80
14.4	Parameter Values	81
15	Busbar Adjustment Procedure	84

1 About This Manual

The examples and diagrams in this manual are included solely for illustrative purposes.

The information contained in this manual is subject to change at any time and without prior notice. In no event will responsibility or liability be accepted for direct, indirect or consequential damages resulting from the use or application of this equipment.

**WARNING**

Indicates a hazard that may cause personal injury or death.

**CAUTION**

Indicates a hazard that may damage the equipment or installation.

**NOTE**

Provides helpful information.

2 Caution Statements

Caution Statements cannot cover every potential cause of equipment damage but can highlight common causes of damage. It is the installer's responsibility to read and understand all instructions in this manual prior to installing, operating or maintaining the equipment, to follow good electrical practice including applying appropriate personal protective equipment and to seek advice before operating this equipment in a manner other than as described in this manual.



NOTE

The WSIQ2 soft starter is not user serviceable. The unit should only be serviced by authorised service personnel. Unauthorised tampering with the unit will void the product warranty.

2.1 Electrical shock risk



WARNING – ELECTRICAL SHOCK RISK

The voltages present in the following locations can cause severe electric shock and may be lethal:

- AC supply cables and connections
- Output cables and connections
- Many internal parts of the starter

The AC supply must be disconnected from the starter using an approved isolation device before any cover is removed from the starter or before any servicing work is performed.



WARNING - ELECTRICAL SHOCK HAZARD

The busbar and heatsink must be treated as live whenever the unit has mains voltage connected (including when the starter is tripped or waiting for a command).



SHORT CIRCUIT

The WSIQ2 is not short circuit proof. After severe overload or short circuit, the operation of the WSIQ2 should be fully tested by an authorised service agent.



GROUNDING AND BRANCH CIRCUIT PROTECTION

It is the responsibility of the user or person installing the WSIQ2 to provide proper grounding and branch circuit protection according to local electrical safety codes.



FOR YOUR SAFETY

- The STOP function of the soft starter does not isolate dangerous voltages from the output of the starter. The soft starter must be disconnected by an approved electrical isolation device before accessing electrical connections.
- Soft starter protection features apply to motor protection only. It is the user's responsibility to ensure safety of personnel operating machinery.
- The soft starter is a component designed for integration within an electrical system; it is therefore the responsibility of the system designer/user to ensure the system is safe and designed to comply with relevant local safety standards.

2.2 Unexpected Operation



WARNING – ACCIDENTAL STARTS

In some installations, accidental starts may pose an increased risk to safety of personnel or damage to the machines being driven. In such cases, it is recommended that the power supply to the soft starter is fitted with an isolating switch and a circuit-breaking device (eg power contactor) controllable through an external safety system (eg emergency stop, fault detector).



WARNING – STARTER MAY START OR STOP UNEXPECTEDLY

The WSIQ2 will respond to control commands from various sources, and could start or stop unexpectedly. Always disconnect the soft starter from mains voltage before accessing the starter or load.



AUTO-START

Use the auto-start feature with caution. Read all the notes related to auto-start before operation.

**WARNING – DISCONNECT MAINS BEFORE ACCESSING STARTER OR LOAD**

The soft starter has built-in protections which can trip the starter in the event of faults and thus stop the motor. Voltage fluctuations, power cuts and motor jams may also cause the motor to trip.

The motor could restart after the causes of shutdown are rectified, which may be dangerous for personnel. Always disconnect the soft starter from mains voltage before accessing the starter or load.

**CAUTION – MECHANICAL DAMAGE FROM UNEXPECTED RESTART**

The motor could restart after the causes of shutdown are rectified, which may be dangerous for certain machines or installations. In such cases, it is essential that appropriate arrangements are made against restarting after unscheduled stops of the motor.

3 Avertissements à l'attention des clients canadiens



AVERTISSEMENT

L'icône AVERTISSEMENT ci-contre signale les informations concernant des risques pouvant entraîner des blessures graves, voire mortelles. Pour votre sécurité, veuillez consulter les avertissements sur cette page ou demander une copie du présent manuel en français auprès de votre distributeur local.



AVERTISSEMENT – RISQUE DE CHOC ÉLECTRIQUE

Les zones suivantes sont soumises à des tensions pouvant provoquer des risques de chocs électriques graves, voire mortels :

- Raccordement et câbles d'alimentation AC
- Câbles et raccordements de sortie
- De nombreuses pièces internes du démarreur

L'alimentation AC doit être déconnectée du démarreur au moyen d'un dispositif d'isolation agréé avant de retirer des capots ou avant de procéder à des travaux d'entretien.



AVERTISSEMENT - DANGER D'ELECTROCUTION

Les barres de puissance et le radiateur doivent être traités comme étant des éléments sous tension si l'appareil est relié au secteur (y compris lorsque le démarreur s'est mis en sécurité ou s'il attend une commande).



AVERTISSEMENT – DÉMARRAGES ACCIDENTELS

Dans certaines installations, des démarrages accidentels peuvent provoquer un risque supplémentaire pour la sécurité des personnes ou endommager les machines contrôlées. Dans de tels cas, il est recommandé de doter l'alimentation du démarreur progressif d'un interrupteur d'isolement et d'un coupe-circuit (par exemple, un disjoncteur) contrôlable à partir d'un système de sécurité externe (par exemple, un arrêt d'urgence, un détecteur de défaut).



AVERTISSEMENT – LE DÉMARREUR PEUT DÉMARRER OU S'ARRÊTER À TOUT MOMENT

Le WSIQ2 répond aux commandes de contrôle de différentes origines et peut par conséquent démarrer ou s'arrêter à tout moment. Toujours déconnecter le démarreur de la tension secteur avant d'accéder au démarreur ou à la charge.



DEMARRAGE AUTOMATIQUE

Utiliser la fonction de démarrage automatique avec précautions. Lire toutes les notes relatives au démarrage automatique avant utilisation.



AVERTISSEMENT

Cette fonction ne doit pas être utilisée en association avec la commande à distance 2 fils.

Le démarreur progressif acceptera encore les commandes de démarrage et d'arrêt issues des entrées de commande à distance ou du réseau de communication série. Pour désactiver la commande locale ou à distance, utiliser le parameter 6Q.

Si le démarrage automatique est activé et que l'utilisateur navigue dans le système de menus, ce démarrage ne deviendra actif que si aucune activité du clavier n'est détectée pendant cinq minutes.



AVERTISSEMENT

Le bouton STOP (ARRET) du clavier est toujours actif. Lors de l'utilisation d'une commande à distance 2 fils, le démarreur progressif redémarrera si les entrées de démarrage/arrêt et de reset sont toujours actives.



AVERTISSEMENT – DÉCONNECTER L'ALIMENTATION PRINCIPALE AVANT D'ACCÉDER AU DÉMARREUR OU À LA CHARGE

Le démarreur progressif comporte des protections intégrées qui peuvent déclencher des mises en sécurité dans l'éventualité de défauts et ainsi arrêter le moteur. Des fluctuations de tension, des coupures d'alimentation et des blocages du moteur peuvent produire des mises en sécurité de celui-ci.

Le moteur pourrait redémarrer une fois que les causes de l'arrêt ont été résolues, ce qui pourrait mettre en danger le personnel. Toujours déconnecter le démarreur de la tension secteur avant d'accéder au démarreur ou à la charge.

**AVERTISSEMENT**

Ne pas appliquer la tension du secteur au démarreur tant que tout le câblage n'est pas terminé.

**AVERTISSEMENT**

Toujours appliquer la tension de commande avant (ou en même temps que) la tension secteur.

**AVERTISSEMENT**

Lors du raccordement du WSIQ2 en connexion 6 fils, toujours installer un contacteur principal ou un disjoncteur magnéto-thermique à bobine de déclenchement.

4 Introduction

4.1 Feature List

Selectable soft starting profiles

- Adaptive Control
- Constant Current
- Current Ramp

Selectable soft stopping profiles

- Coast To Stop
- Timed voltage ramp soft stop
- Adaptive Control
- Brake

Extensive input and output options

- Remote control inputs
(3 x fixed, 2 x programmable)
- Relay outputs
(1 x fixed, 3 x programmable)
- Analog output
- Built-in PT100 RTD input
- Optional expansion cards

Easy-to-read display with comprehensive feedback

- Removable keypad
- Multi-language feedback
- Date and time stamped event logging
- Operational counters (number of starts, hours-run, kWh)
- Performance monitoring (current, voltage, power factor, kWh)
- User-programmable monitoring screen

Customisable protection

- Motor overload
- Excess Start Time
- Undercurrent
- Instantaneous overcurrent
- Current imbalance
- Mains frequency
- Input Trip
- Motor thermistor
- Power circuit
- Phase sequence

Models for all connection requirements

- 360 A~1600 A (nominal)
- 380~690 VAC
- In-line or inside delta connection

Optional features for advanced applications

- Input/output expansion
- RTD and Ground fault protection
- Communication modules: Ethernet (Profinet, Modbus TCP, Ethernet/IP), Profibus, DeviceNet, Modbus RTU, and USB

5 Basic Setup

5.1 Setup Procedure Overview



WARNING

Do not apply mains voltage to the starter until all wiring is complete.

1. Mount the soft starter (refer to Physical Installation on page 10 for details).
2. Connect control wiring (refer to Control Terminals on page 10 for details).
3. Apply control voltage to the starter.
4. Set the date and time (refer to Set Date and Time on page 22 for details).
5. Configure your application:
 1. Press **MENU** to open the Menu.
 2. Use ▼ to scroll to Quick Setup and press ► to open the Quick Setup menu.
 3. Scroll through the list to find your application, then press **ENTER/MENU** to begin the configuration process (refer to Quick Setup on page 34 for details).
6. If your application is not listed in Quick Setup:
 1. Press ◀ to return to the Menu.
 2. Use ▼ to scroll to Standard Menu and press ►.
 3. Scroll to Motor Data 1 and press ►, then press ► again to edit parameter 1A *Motor Full Load Current*.
 4. Set parameter 1A to match the motor's full load current (FLC).



NOTE

For advanced applications, refer to Extended Menu on page 36 and Parameter Descriptions on page 40.

7. Close the Menu by pressing ◀ repeatedly.
8. (Optional) Use the built-in simulation tools to check that the control wiring is connected correctly (refer to Run Simulation on page 23).
9. Connect mains supply cables to starter input terminals 1/L1, 3/L2, 5/L3 (refer to Power Input and Output Configurations on page 12).
10. Connect the motor cables to starter output terminals 2/T1, 4/T2, 6/T3.
The soft starter is now ready to control the motor.

5.2 Testing the Installation

The WSIQ2 can be connected to a small motor for testing. During this test, the soft starter's control input and relay output protection settings can be tested. This test mode is not suitable for testing soft starting or soft stopping performance.

The FLC of the test motor must be at least 2% of the soft starter's minimum FLC (refer to *Minimum and Maximum Current Settings* on page 77).



NOTE

When testing the soft starter with a small motor, set parameter 1A *Motor Full Load Current* to the minimum allowable value.

5.3 Simulation Tools

Software simulation functions let you test the soft starter's operation and control circuits without connecting the soft starter to mains voltage.

- The run simulation simulates a motor starting, running and stopping to confirm that the soft starter and associated equipment have been installed correctly. Refer to Run Simulation on page 23 for details.
- The protection simulation simulates activation of each protection mechanism to confirm that the soft starter and associated control circuits are responding correctly. Refer to Protection Simulation on page 23 for details.
- The output signal simulation simulates output signalling to confirm that outputs and associated control circuits are operating correctly. Refer to Output Signal Simulation on page 23 for details.

The simulations are only available when the soft starter is in Ready state, control voltage is available and the keypad is active.



NOTE

Access to the simulation tools is protected by the security access code. The default access code is 0000.

6 Installation

6.1 Physical Installation

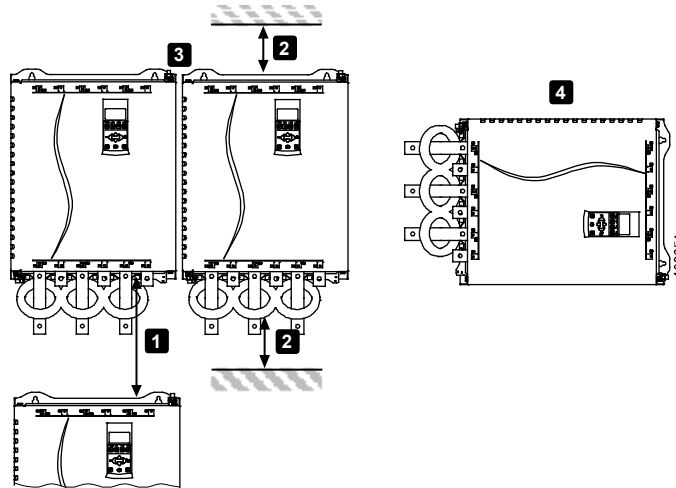

1	Allow 200 mm (7.88 inches) between soft starters.
2	Allow 200 mm (7.88 inches) between the soft starter and solid surfaces.
3	Soft starters may be mounted side by side with no clearance (that is, if mounted without communications modules).
4	The soft starter may be mounted on its side. Derate the soft starter's rated current by 15%.

6.2 Control Terminals

Control terminations use 2.5mm² plug-in terminal blocks. Unplug each block, complete the wiring, then reinsert the block.

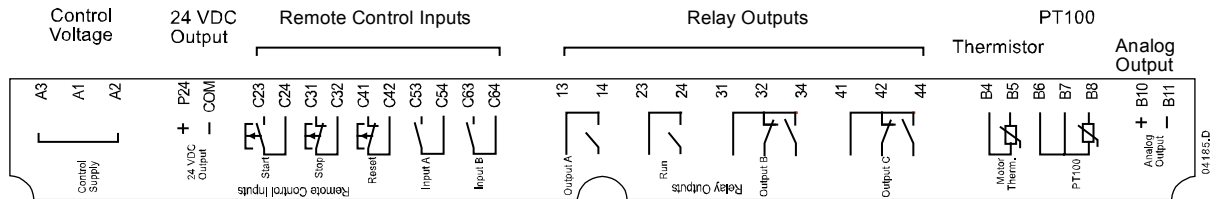

6.3 Control Voltage

Different models require control voltage to different terminals:

- WSIQ2-xxxxC (110~210 VAC) A1, A2
- WSIQ2-xxxxC (220~440 VAC) A2, A3
- WSIQ2-xxxxC-24 (24 VAC/VDC) A1, A3

6.4 Control Wiring

The WSIQ2 has three fixed inputs for remote control. These inputs should be controlled by contacts rated for low voltage, low current operation (gold flash or similar).

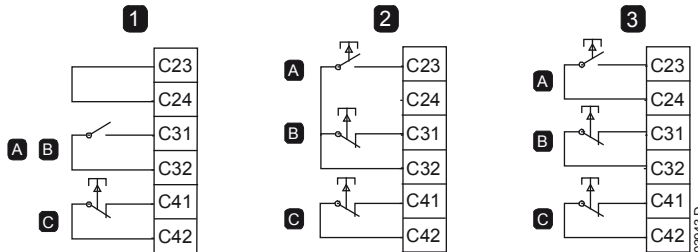

1	Two-wire control
2	Three-wire control
3	Four-wire control
A	Start
B	Stop
C	Reset



CAUTION

The control inputs are powered by the soft starter. Do not apply external voltage to the control input terminals.

Cables to the control inputs must be segregated from mains voltage and motor cabling.

The reset input can be normally open or normally closed. Use parameter 6M to select the configuration.

6.5 Relay Outputs

The WSIQ2 provides four relay outputs, one fixed and three programmable.

The Run output closes when the soft start is complete (when the starting current falls below 120% of the programmed motor full load current) and remains closed until the beginning of a stop (either soft stop or coast to stop).

Operation of the programmable outputs is determined by the settings of parameters 7A~7I.

- If assigned to Main Contactor, the output activates as soon as the soft starter receives a start command and remains active while the soft starter is controlling the motor (until the motor starts a coast to stop, or until the end of a soft stop).
- If assigned to a trip function, the output activates when a trip occurs.
- If assigned to a flag, the output activates when the specified flag is active (parameters 7M~7O).



CAUTION

Some electronic contactor coils are not suitable for direct switching with PCB mount relays. Consult the contactor manufacturer/supplier to confirm suitability.

Three additional outputs are available on the input/output expansion card.

6.6 Motor Thermistors

Motor thermistors can be connected directly to the WSIQ2. The soft starter will trip when the resistance of the thermistor circuit exceeds approximately 3.6 k Ω or falls below 20 Ω .

If no motor thermistors are connected to the WSIQ2 thermistor input terminals B4, B5 must be open. If B4, B5 are shorted, the WSIQ2 will trip.

The thermistor input is disabled by default, but activates automatically when a thermistor is detected. If thermistors have previously been connected to the WSIQ2 but are no longer required, either:

- connect a 1.2 k Ω resistor between B4, B5 or
- reset the starter to factory defaults (refer to). If you wish to retain the starter's configuration, save the starter's settings to a user set before resetting. Reload the settings after the thermistor input has been reset



NOTE

The thermistor circuit should be run in screened cable and must be electrically isolated from earth and all other power and control circuits.

6.7 RTD/PT100

RTDs (PT100) can be connected directly to the WSIQ2. RTD/PT100s B ~ G are only available if the RTD/PT100 and Ground Fault expansion card is fitted.

The soft starter will trip when the temperature exceeds the value specified in parameters 11A~11G (refer to *11 RTD Temperatures*). When fitting an RTD/PT100, always review the parameter settings. The default value for each RTD/PT100 input is 50 °C.

The RTD/PT100 input is disabled by default, but activates automatically when an RTD/PT100 is detected.



NOTE

Resistors are required on any unused RTD inputs to avoid trips from electrical fast transient (EFT) noise. When connecting an RTD, remove the resistor and associated jumper wire.

If RTD/PT100s have previously been connected to the WSIQ2 but are no longer required, either:

- connect a 120 Ω ~160 Ω resistor between Signal + and Return – (B6, B8) to ensure the input remains at a known value, then adjust parameter(s) 11A~11G so that the starter does not trip or
- reset the starter to factory defaults (refer to). If you wish to retain the starter's configuration, save the starter's settings to a user set before resetting. Reload the settings after the RTD/PT100 input has been reset

6.8 Earth Terminals

Earth terminals are located at the back of the soft starter, one on the input side (top) and one on the output side (bottom).

6.9 Power Input and Output Configurations

The WSIQ2 has dedicated bypass terminals, on the input busbars. The bypass terminals are L1B, L2B, L3B.

The busbars can be adjusted for top or bottom input and output as required. Refer to Busbar Adjustment Procedure on page 84 for step-by-step instructions. All units are manufactured bottom in/bottom out.

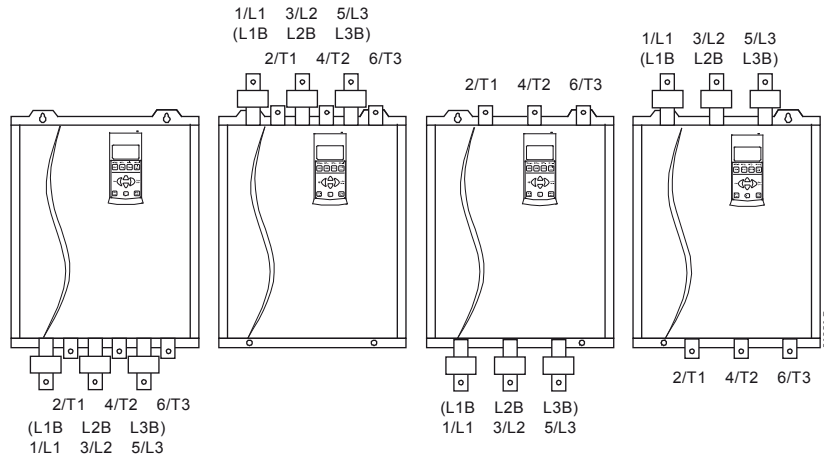

6.10 Power Terminations



NOTE

Some units use aluminium busbars. When connecting power terminations, we recommend cleaning the surface contact area thoroughly (using an emery or stainless steel brush) and using an appropriate jointing compound to prevent corrosion.

Use only copper stranded or solid conductors, rated for 75 °C or higher.

WSIQ2-0360C~WSIQ2-0930C	WSIQ2-1200C~WSIQ2-1600C
<p style="text-align: center;">38 Nm (28.0 ft-lb)</p>	<p style="text-align: center;">66 Nm (48.7 ft-lb)</p>

6.11 Schematic Diagrams

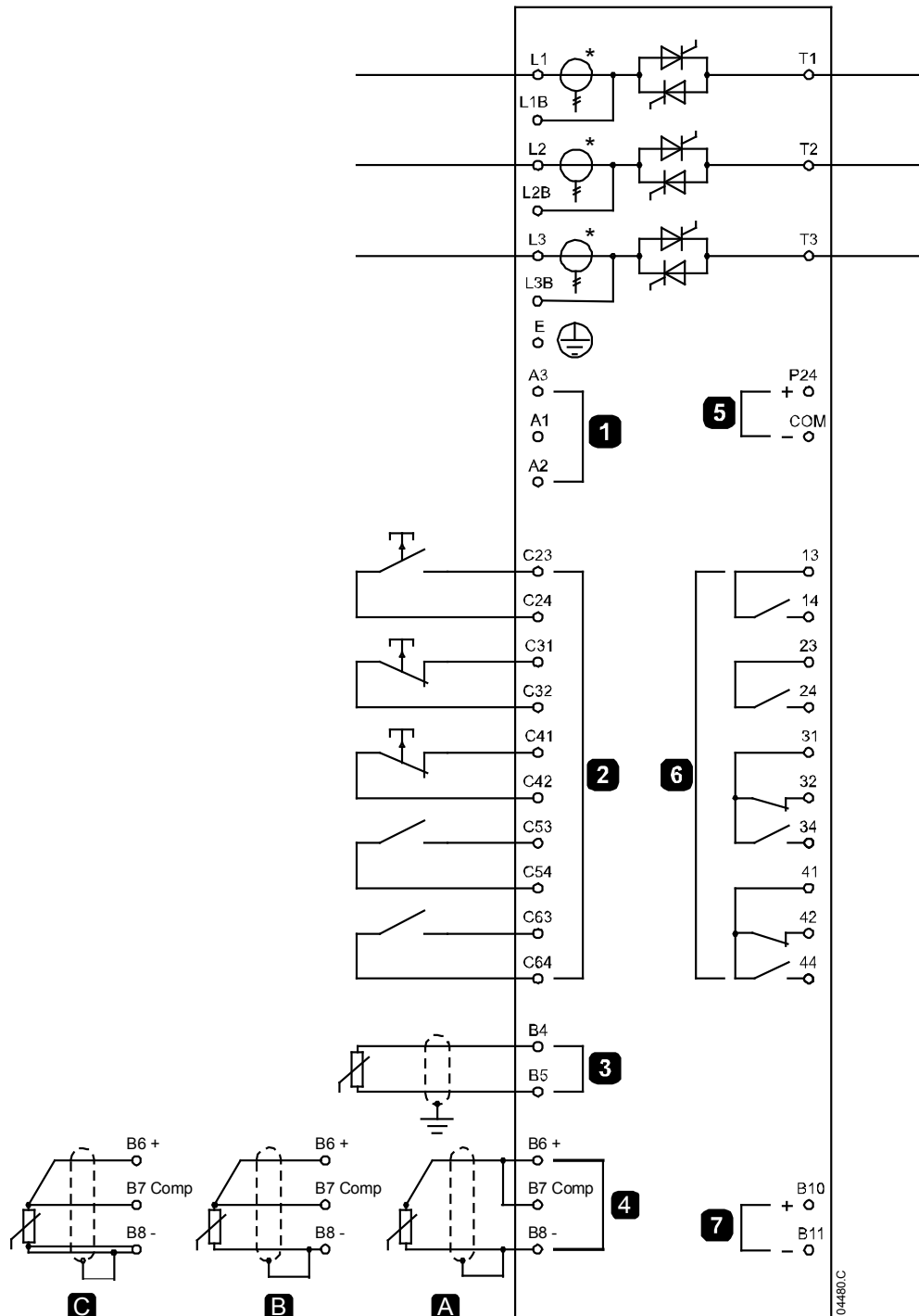

1	Control voltage (model dependent)
2	Remote control inputs
3	Motor thermistor input
4A	RTD/PT100 input - 2-wire
4B	RTD/PT100 input - 3-wire
4C	RTD/PT100 input - 4-wire
5	24 VDC output
6	Relay outputs
7	Analog output

C23, C24	Start
C31, C32	Stop
C41, C42	Reset
C53, C54	Programmable input A
C63, C64	Programmable input B
13, 14	Relay output A
23, 24	Run relay output
31, 32, 34	Relay output B
41, 42, 44	Relay output C

Different models require control voltage to different terminals:

- WSIQ2-xxxxC (110~210 VAC) A1, A2
- WSIQ2-xxxxC (220~440 VAC) A2, A3
- WSIQ2-xxxxC-24 (24 VAC/VDC) A1, A3

7 Power Circuits

7.1 Motor Connection

The WSIQ2 can be connected to the motor in-line or inside delta (also called three-wire and six-wire connection). When connecting in inside delta, enter the motor full load current (FLC) for parameter 1A. The WSIQ2 will automatically detect whether the motor is connected in-line or inside delta and will calculate the correct inside delta current level.

In-line installation, externally bypassed

Non-bypassed models have dedicated bypass terminals, which allow the WSIQ2 to continue providing protection and monitoring functions even when bypassed via an external bypass contactor. The bypass contactor must be connected to the bypass terminals and controlled by the soft starter's run output (terminals 23, 24).

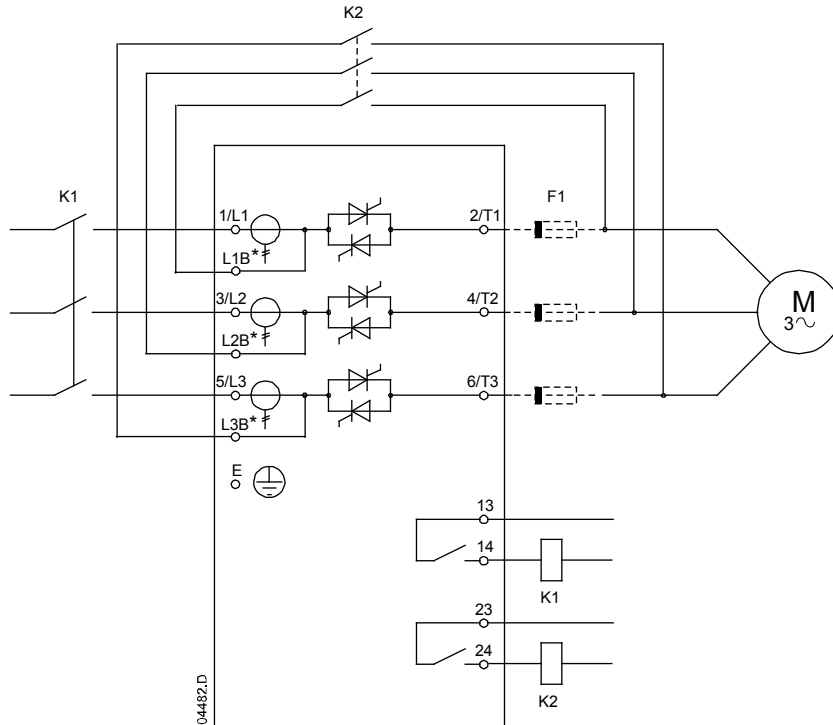

K1	Main contactor
K2	Bypass contactor (external)
F1	Semiconductor fuses (optional)

In-line installation, non-bypassed

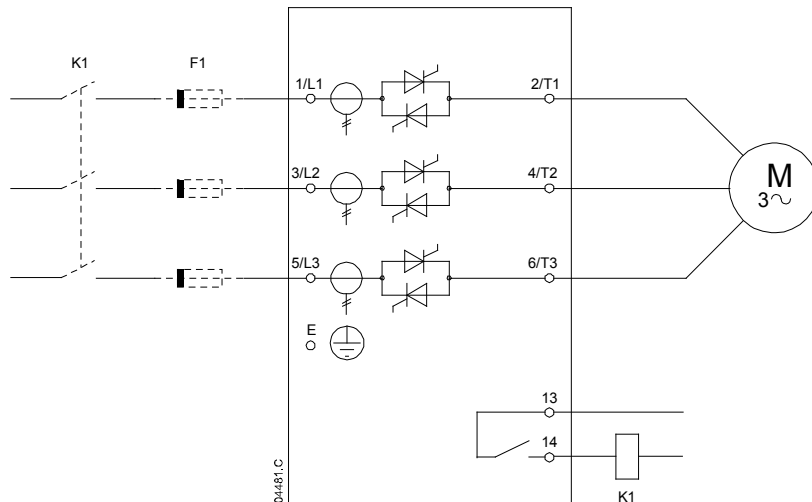

K1	Main contactor (optional)
F1	Semiconductor fuses (optional)
13, 14	Relay output A (= Main Contactor, default)

Inside delta installation, externally bypassed

Non-bypassed models have dedicated bypass terminals, which allow the WSIQ2 to continue providing protection and monitoring functions even when bypassed via an external bypass contactor. The bypass contactor must be connected to the bypass terminals and controlled by the soft starter's run output (terminals 23, 24).

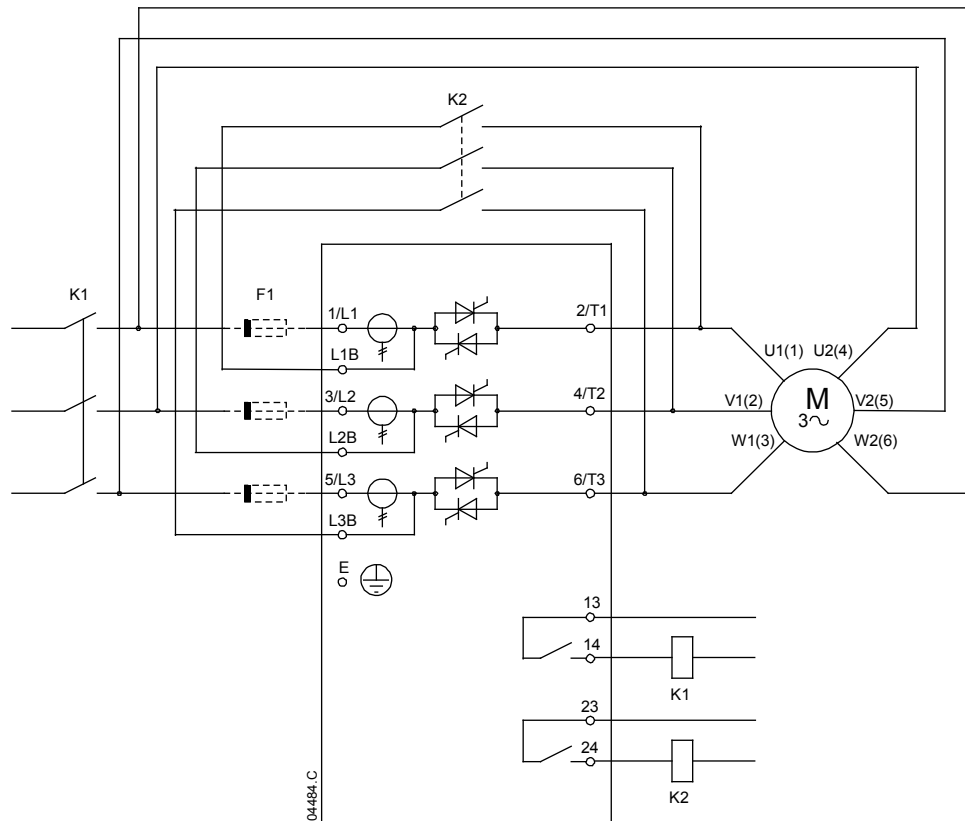

K1	Main contactor (strongly recommended)
K2	Bypass contactor (external)
F1	Semiconductor fuses (optional)
13, 14	Relay output A (= Main Contactor, default)
23, 24	Run relay output

Inside delta installation, non-bypassed

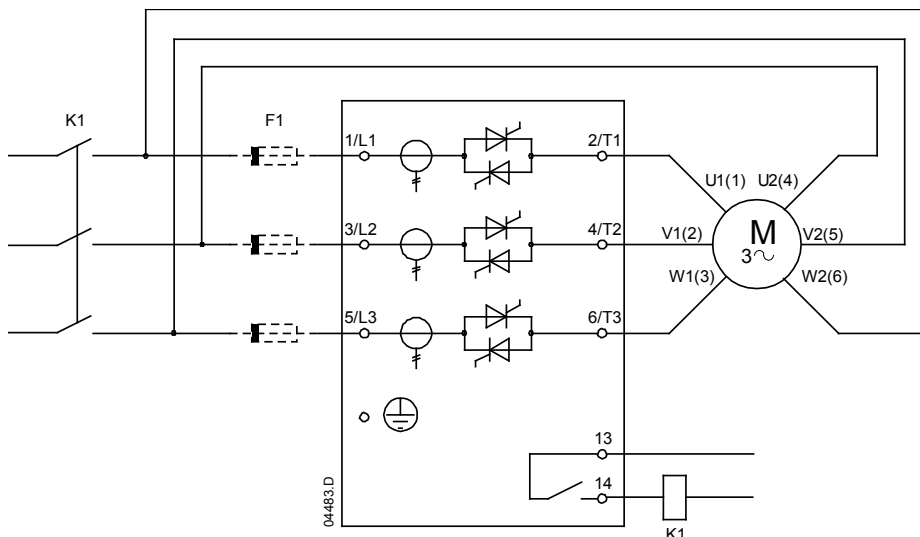

K1	Main contactor (strongly recommended)
F1	Semiconductor fuses (optional)
13, 14	Relay output A (= Main Contactor, default)

7.2 Bypass Contactor

Non-bypassed soft starters may be installed with an external bypass contactor. Select a contactor with an AC1 rating greater than or equal to the full load current rating of the connected motor.

7.3 Main Contactor

A main contactor must be installed if the WSIQ2 is connected to the motor in inside delta format and is optional for in-line connection. Select a contactor with an AC3 rating greater than or equal to the full load current rating of the connected motor.

7.4 Circuit Breaker

A shunt trip circuit breaker may be used instead of a main contactor to isolate the motor circuit in the event of a soft starter trip. The shunt trip mechanism must be powered from the supply side of the circuit breaker or from a separate control supply.

7.5 Power Factor Correction

If power factor correction is used, a dedicated contactor should be used to switch in the capacitors.

To use the WSIQ2 to control power factor correction, connect the PFC contactor to a programmable relay set to Run. When the motor reaches full speed, the relay will close and power factor correction will be switched in.



CAUTION

Power factor correction capacitors must be connected to the input side of the soft starter. Connecting power factor correction capacitors to the output side will damage the soft starter.

7.6 Short Circuit Protection Devices (SCPD)

Fuses may be installed to protect the soft starter or the installation.

Type 1 Coordination

Type 1 coordination requires that, in the event of a short circuit on the output side of a soft starter, the fault must be cleared without risk of injury to personnel. There is no requirement that the soft starter must remain operational after the fault.

HRC fuses (such as Ferraz/Mersen AJT fuses) can be used for Type 1 coordination according to IEC 60947-4-2 standard.

Type 2 Coordination

Type 2 coordination requires that in the event of a short circuit on the output side of a soft starter, the fault must be cleared without risk of injury to personnel or damage to the soft starter.

Semiconductor fuses for Type 2 circuit protection are additional to HRC fuses or MCCBs that form part of the motor branch circuit protection.



CAUTION

Adaptive Control controls the motor's speed profile, within the programmed time limit. This may result in a higher level of current than traditional control methods.



CAUTION

DC Brake: A high brake torque setting can result in peak currents up to motor DOL being drawn while the motor is stopping. Ensure protection fuses installed in the motor branch circuit are selected appropriately.



CAUTION

Integral solid state short circuit protection does not provide branch circuit protection. Branch circuit protection must be provided in accordance with the National Electrical Code and any additional local codes.

7.7 UL Short Circuit Ratings

Short circuit current ratings (SCCR) are available for 480 VAC and 600 VAC installations.

- **480 VAC circuits**

For UL compliant installation, select a fuse that meets the specified fuse class and maximum fuse rating.

- **600 VAC circuits**

For UL compliant installation, the starter can be protected by either fuses or a circuit breaker as specified in the following tables.

Fuse selection

Model	@480 VAC		@600 VAC			
	Short circuit rating	Max. Fuse Rating (A) (fuse class)	Short circuit rating	Ferraz/Mersen fuse, Listed J, L or RK5 Class Fuse	Ferraz/Mersen fuse, R/C semi-conductor fuses	600 V Short cct rating – 3 cycles †
WSIQ2-0360C	100 kA	600 (L)	100 kA	Any 600 A, Class L	A070URD33XXX0630	Not available
WSIQ2-0380C		600 (L)		Any 600 A, Class L	A070URD33XXX0700	
WSIQ2-0430C		800 (L)		Any 800 A, Class L	A070URD33XXX0700	
WSIQ2-0620C		1200 (L)		Any 1200 A, Class L	A070URD33XXX1000	
WSIQ2-0650C					A070URD33XXX1000	
WSIQ2-0790C					A070URD33XXX1400	
WSIQ2-0930C					A070URD33XXX1400	
WSIQ2-1200C	65 kA	1600 (L)	A4BQ1600	A065URD33XXX1800		
WSIQ2-1410C		2000 (L)	A4BQ2000	A055URD33XXX2250		
WSIQ2-1600C		2000 (L)	A4BQ2500	A050URD33XXX2500		

XXX = blade type. Refer to Ferraz/Mersen catalog for details.

† - Models provided with a “3 cycle rating” are suitable for use in a circuit with the prospective current noted, when protected by any UL Listed fuses or UL Listed circuit breakers sized according to the NEC.

Circuit breaker selection

Model	Short circuit rating @480 VAC	Breaker 1: Eaton Part Number (rating, A)	Breaker 2: GE Part Number (rating, A)	Breaker 3: LSIS Part Number (rating, A)	480V/ 600 V standard short circuit rating	
WSIQ2-0360C	65 kA	Not suitable	SGLA36AT600 (1000)	UTS600HU/	18 kA	
WSIQ2-0380C			SGLA36AT800 (1000)	UTS800HU (1000)		
WSIQ2-0430C			SGLA36AT800 (1200)	UTS600HU/ UTS800HU/ UTS1200HU (1200)	30 kA	
WSIQ2-0620C			SKLA36AT1200 (1200)	UTS800/ UTS1200 (1200)	UTS1200 (1200)	42 kA
WSIQ2-0650C						
WSIQ2-0790C						
WSIQ2-0930C						
WSIQ2-1200C	85 kA	Siemens: HPX3R1600 (1600)			85 kA	
WSIQ2-1410C						
WSIQ2-1600C						

7.8 Fuse Selection for Type 2 Coordination

Type 2 coordination is achieved by using semiconductor fuses. These fuses must be able to carry motor start current and have a total clearing I^2t less than the I^2t of the soft starter SCRs.

When selecting semiconductor fuses for WSIQ2, use the I^2t values in the table.

For further information on selecting semiconductor fuses, contact your local distributor.

Model	SCR I^2t (A ² s)
WSIQ2-0360C	320000
WSIQ2-0380C	320000
WSIQ2-0430C	320000
WSIQ2-0620C	1200000
WSIQ2-0650C	1200000
WSIQ2-0790C	2530000
WSIQ2-0930C	4500000
WSIQ2-1200C	4500000
WSIQ2-1410C	6480000
WSIQ2-1600C	12500000

8 Keypad and Feedback

8.1 The Keypad

The keypad stores a backup copy of the parameters in the soft starter, so one keypad can be used to program multiple WSIQ2 starters.

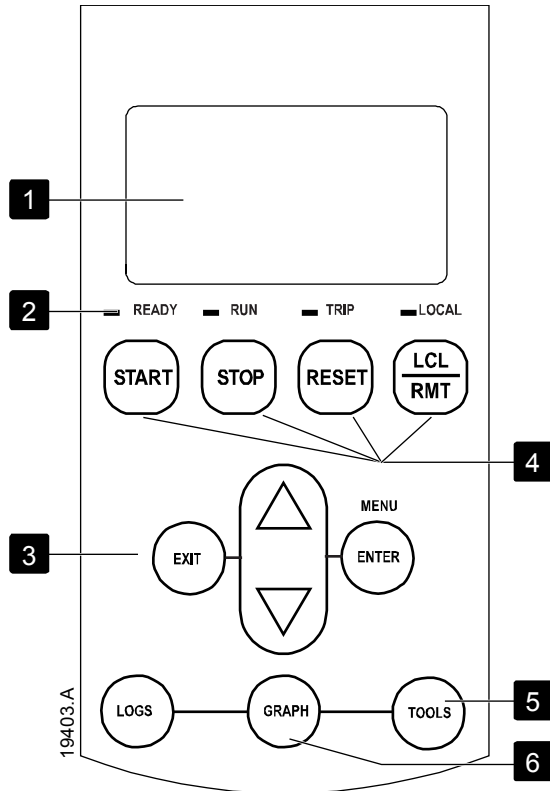

1	Four-line display for status and programming details.
2	Status LEDs
3	Menu navigation buttons: ◀ : Exit the menu or parameter, or cancel a parameter change. ENTER/MENU : Enter a menu or parameter, or save a parameter change. ▲ / ▼ : Scroll to the next or previous menu or parameter, or change the setting of the current parameter.
4	Soft starter local control buttons
5	Shortcut buttons for quick access to common tasks.
6	Alt button. Use with F1 or F2 to open performance logs or commissioning tools.

8.2 Starter Status LEDs

LED name	On	Flashing
Ready	The motor is stopped and the starter is ready to start.	The motor is stopped and the starter is waiting for the <i>Restart Delay</i> (parameter 4M) or <i>Motor Temperature Check</i> (parameter 4N).
Run	The motor is in run state (receiving full voltage).	The motor is starting or stopping.
Trip	The starter has tripped.	The starter is in warning state.
Local	The starter is in Local control mode.	–

If the starter is in remote control mode, the Local LED will be off.

If all LEDs are off, the starter is not receiving control voltage.

8.3 Removing and Replacing the Keypad

The keypad can be removed from the soft starter and mounted remotely on a panel using the remote mounting kit.



NOTE

The keypad can be removed or replaced while the starter is running. It is not necessary to remove mains or control voltage.

Removing the keypad

The keypad is attached to the body of the soft starter by a DB9 serial connector and two screws. The screws are concealed behind a snap-on faceplate.

To remove the keypad:

1. Remove the starter's front cover.
2. Insert a small screwdriver under the faceplate, at the base of the keypad, and use the screwdriver to lever the faceplate off the keypad.
3. Lift the faceplate off completely.
4. Remove the two screws holding the keypad in place.
5. Lift the keypad gently off the soft starter. Pull the keypad forwards, to avoid damaging the DB9 connector.

Reattaching the keypad

To reattach the keypad:

1. Align the connector on the back of the keypad with the socket on the soft starter and push the keypad firmly into place. The keypad will be held in place by the connector and two locating nibs in the top right and bottom left corners.
For temporary installation (eg during commissioning) it is not necessary to screw the keypad in place.
2. Replace the two screws holding the keypad in place.
3. Slide the bottom edge of the faceplate over the body of the keypad, then swing the top edge of the faceplate into place and press onto the keypad. The retaining tabs on the back of the faceplate will snap into place.

Synchronising the Keypad and the Starter

When a keypad is connected to an WSIQ2, it synchronises its parameter settings with the settings in the soft starter.

Every time a different keypad is plugged into the starter, an acknowledgement is displayed.

New Display Detected

Select the required option using the ▲ and ▼ buttons. Press **STORE** to proceed with the selection.

Copy Parameters
Display to Starter
Starter to Display

If any of the settings in the keypad are not valid for the starter, the keypad loads the default values.

8.4 Displays

The keypad displays a wide range of performance information about the soft starter. The top half of the screen shows real-time information on current or motor power (as selected in parameter 8D). Use the ▲ and ▼ buttons to select the information shown on the bottom half of the screen.

- Starter status
- Motor temperature
- Current
- Motor power
- Last start information
- Date and time
- SCR conduction



NOTE

Screens shown here are with the default settings.

Starter Status

The starter status screen shows details of the starter's operating status, motor temperature and motor power.

```
Ready
M1 000%      000.0kW
```

Programmable screen

The WSIQ2's user-programmable screen can be configured to show the most important information for the particular application. Use parameters 8E to 8H to select which information to display.

```
Ready
0000 hrs      - - %
```

Motor Temperature

The temperature screen shows which motor data set is in use, and the temperature of both motors as a percentage of total thermal capacity. If the WSIQ2 is configured for use on one motor, the temperature for the secondary motor (M2) will always show 0%.

```
Primary Motor Set
▶ M1 000%      M2 000%
```

Current

The current screen shows real-time line current on each phase. If the RTD/PT100 and ground fault protection card is fitted, the screen will also show ground current.

```
Phase Currents
000.0A 000.0A 000.0A
```

Motor Power

The motor power screen shows motor power (kW, HP and kVA) and power factor.

```
000.0kW      0000HP
0000kVA      - . - - pf
```

The motor power figures are calculated using the Mains Reference Voltage (parameter 8N).

Last Start Information

The last start information screen shows details of the most recent successful start:

- start duration (seconds)
- maximum start current drawn (as a percentage of motor full load current)
- calculated rise in motor temperature

```
Last start      010 s
350 % FLC      Δ Temp 5%
```

Date and Time

The date/time screen shows the current system date and time (24 hour format). For details on setting the date and time, refer to *Set Date and Time* on page 22.

Performance Graph

The performance graph provides a real-time display of operating performance. Use parameters 8I~8L to select which information to display.

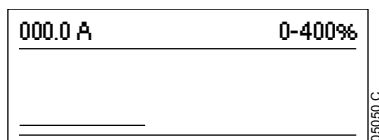

SCR Conduction Bargraph

The SCR conduction bargraph shows the level of conduction on each phase.

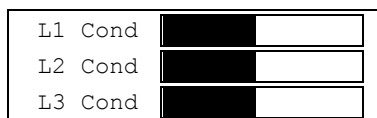

9 Maintenance Tools

9.1 Testing the Installation

The WSIQ2 can be connected to a small motor for testing. During this test, the soft starter's control input and relay output protection settings can be tested. This test mode is not suitable for testing soft starting or soft stopping performance.

The FLC of the test motor must be at least 2% of the soft starter's minimum FLC (refer to *Minimum and Maximum Current Settings* on page 77).

**NOTE**

When testing the soft starter with a small motor, set parameter 1A *Motor Full Load Current* to the minimum allowable value.

9.2 Commissioning Menu (Tools)

The Commissioning Menu provides access to commissioning and testing tools.

Press **ALT** then **TOOLS** to open the Tools.

To navigate through the Commissioning Menu:

- to scroll to the next or previous item, press the ▲ or ▼ button.
- to open an item for viewing, press the ► button.
- to return to the previous level, press the ◀ button.
- to close the Commissioning Menu, press ◀ repeatedly.

Set Date and Time

To set the date and time:

1. Press **ALT** then **TOOLS** to open the Tools.
2. Scroll to the date/time screen.
3. Press the **ENTER/MENU** button to enter edit mode.
4. Press the **ENTER/MENU** and ◀ buttons to select which part of the date or time to edit.
5. Use the ▲ and ▼ buttons to change the value.
6. To save changes, press the **ENTER/MENU** button. The WSIQ2 will confirm the changes.
To cancel changes, press the ◀ button.

Simulation Tools

Software simulation functions let you test the soft starter's operation and control circuits without connecting the soft starter to mains voltage. The WSIQ2 has three simulation modes:

- The run simulation simulates a motor starting, running and stopping to confirm that the soft starter and associated equipment have been installed correctly.
- The protection simulation simulates activation of each protection mechanism to confirm that the soft starter and associated control circuits are responding correctly.
- The output signal simulation simulates output signalling to confirm that outputs and associated control circuits are operating correctly.

The simulation tools are accessed via the Commissioning Menu. The simulations are only available when the soft starter is in Ready state, control voltage is available and the keypad is active.

**NOTE**

Access to the simulation tools is protected by the security access code. The default access code is 0000.

Run Simulation

You can end the simulation at any time by pressing **RESET/EXIT**.

To use the run simulation:

1. Press **ALT** then **TOOLS** to open the Tools.
2. Scroll to Run Simulation and press **ENTER/MENU**.
3. Press **START** or activate the start input. The WSIQ2 simulates its pre-start checks and closes the main contactor relay. The Run LED flashes.



NOTE

If mains voltage is connected, an error message is shown. Remove mains voltage and proceed to the next step.

4. Press **ENTER/MENU**. The WSIQ2 simulates starting. The Run LED flashes.
5. Press **▶**. The WSIQ2 simulates running. The Run LED stays on without flashing and the bypass contactor relay closes.
6. Press **STOP** or activate the stop input. The WSIQ2 simulates stopping. The Run LED flashes and the bypass contactor relay opens.
7. Press **ENTER/MENU**. The Ready LED flashes and the main contactor relay opens.
8. Press **▶** to return to the commissioning menu.

Run Simulation Ready Apply Start Signal
Run Simulation Pre-Start Checks STORE to Continue
Run Simulation ATTENTION! Remove Mains Volts STORE to Continue
Run Simulation Starting X:XXs STORE to Continue
Run Simulation Running Apply Stop Signal
Run Simulation Stopping X:XXs STORE to Continue
Run Simulation Stopped STORE to Continue

Protection Simulation

The protection simulation simulates activation of each protection mechanism to confirm that the soft starter and associated control circuits are responding correctly.

To use the protection simulation:

1. Press **ALT** then **TOOLS** to open the Tools.
2. Scroll to Protection Simulation and press **▶**.
3. Use the **▲** and **▼** buttons to select the protection you want to simulate.
4. Press and hold **▶** to simulate the selected protection.
5. The screen is displayed momentarily. The soft starter's response depends on the Protection Action setting (parameter group 16).
6. Use **▲** or **▼** to select another simulation, or press **◀** to exit.

0.0A Tripped Selected Protection
--



NOTE

If the protection trips the soft starter, reset before simulating another protection. If the protection action is set to 'Warn and Log', no reset is required.

If the protection is set to 'Warn and Log', the warning message can be viewed only while the **▶** button is pressed.

If the protection is set to 'Log only', nothing appears on the screen but an entry will appear in the log.

Output Signal Simulation

The output signal simulation simulates output signalling to confirm that outputs and associated control circuits are operating correctly.



NOTE

To test operation of the flags (motor temperature and low/high current), set an output relay to the appropriate function and monitor the relay's behaviour.

To use the output signal simulation:

1. Press **ALT** then **TOOLS** to open the Tools.
2. Scroll to Output Signalling Simulation and press **▶**.
3. Use the **▲** and **▼** buttons to select a function to simulate, then press **▶**.
4. Use the **▲** and **▼** buttons to turn the signal on and off.
To confirm correct operation, monitor the state of the output.
5. Press **◀** to return to the simulation list.

```
Prog Relay A
Off
On
```

Analog Output Simulation

The analog output simulation uses the **▲** and **▼** buttons to change the current at the analog output terminals.

```
Analog Output A
0%
4.0mA
```

Attach a current measuring device to the analog output terminals. Use the **▲** or **▼** button to adjust the percentage value on the display. The current measuring device should indicate the same level of current as shown on the display.

If the input/output expansion card is fitted, the simulation can also be used to test the operation of Relays D, E, F and Analog Output B.

Temperature Sensors State

This screen shows the state of the motor thermistors and RTD/PT100s.
S = Short
H = Hot
C = Cold
O = Open

```
Temp Sensors State
Thermistor: 0
RTD/PT100s:0000000
S = Shrt H=Hot C=Cld
O=Opn
```

RTD/PT100s B ~ G are only available if the RTD/PT100 and Ground Fault expansion card is fitted.

Digital I/O State

This screen shows the current status of the digital inputs and outputs.

```
Digital I/O State
Inputs: 0110000
Outputs: 0000100
```

The top line of the screen shows the start, stop, reset and programmable inputs (A and B, then inputs on the I/O expansion card (if fitted)).

The bottom line of the screen shows programmable output A, the fixed Run output, programmable outputs B and C, then the outputs on the expansion card (if fitted).

Analog I/O State

This screen shows the current status of the Analog I/O

```
Analog I/O State
Input: - - - - %
Output A: 04.0mA
```

This screen will also show Analog Output B if the expansion card is fitted.

Reset Thermal Models

The WSIQ2's advanced thermal modelling software constantly monitors the motor's performance. This allows the WSIQ2 to calculate the motor's temperature and ability to start successfully at any time. If the WSIQ2 is configured for use on two motors, each motor's temperature is modelled separately.

The thermal model for the active motor can be reset if required.

1. Press **ALT** then **TOOLS** to open the Tools.
2. Scroll to Reset Thermal Models and press **▶**.
3. Use **▼** to select Reset and press **STORE** to confirm.
4. When the thermal model has been reset, the screen will display a confirmation message then return to the previous screen.

```
Reset Thermal Models
M1 X%
M2 X%
▶ to Reset
```

```
Do Not Reset
Reset
```



CAUTION

Resetting the motor thermal model will compromise thermal model protection and may compromise motor life. Only reset the thermal model in an emergency.

9.3 Logs Menu

The Logs Menu provides information on events, trips and starter performance.

Press **ALT** then **LOGS** to open the Logs.

To navigate through the Logs Menu:

- to open a log, press the **▶** button.
- to scroll through the entries in each log, press the **▲** and **▼** buttons.
- to view details of a log entry, press the **▶** button.
- to return to the previous level, press the **◀** button.
- to close the Logs Menu, press **◀** repeatedly.

The Logs Menu can only be opened while viewing the monitoring screens.

Trip Log

The Trip Log stores details of the eight most recent trips, including the date and time the trip happened. Trip 1 is the most recent and trip 8 is the oldest stored trip.

To open the Trip Log:

1. Press **ALT** then **LOGS** to open the Logs.
2. Scroll to Trip Log and press **▶**.
3. Use the **▲** and **▼** buttons to select a trip to view, and press **▶** to display details.

To close the log and return to the main display, press **◀** repeatedly.

Event Log

The Event Log stores time-stamped details of the starter's 99 most recent events (actions, warnings and trips), including the date and time of the event. Event 1 is the most recent and event 99 is the oldest stored event.

To open the Event Log:

1. Press **ALT** then **LOGS** to open the Logs.
2. Scroll to Event Log and press **▶**.
3. Use the **▲** and **▼** buttons to select an event to view, and press **▶** to display details.

To close the log and return to the main display, press **◀** repeatedly.

Performance Counters

The performance counters store statistics on the starter's operation:

- Hours run (lifetime and since counter last reset)
- Number of starts (lifetime and since counter last reset)
- Motor kWh (lifetime and since counter last reset)
- Number of times the thermal model has been reset

The resettable counters (hours run, starts and motor kWh) can only be reset if the *Adjustment Lock* (parameter 15B) is set to Read & Write.

To view the counters:

1. Press **ALT** then **LOGS** to open the Logs.
2. Scroll to counters and press **ENTER/MENU**.
3. Use the **▲** and **▼** buttons to scroll through the counters. Press **ENTER/MENU** to view details.
4. To reset a counter, press **ENTER/MENU** then use the **▲** and **▼** buttons to select Reset/Do Not Reset. Press **ENTER** to confirm the action.

To close the counter and return to the Logs Menu, press **ENTER/MENU**.

10 Operation

10.1 Priority of Commands

Starter Disable overrides any other control command. Refer to parameter 6A Input A Function.

Emergency Run overrides normal control commands, including auto-start/stop. Refer to parameter 15C Emergency Run.

Auto-start/stop overrides normal control commands (local, remote or via serial communications). Refer to 3 Auto-Start/Stop on page 42.

10.2 Start, Stop and Reset Commands

The soft starter can be controlled in three ways:

- using the buttons on the keypad
- via remote inputs
- via a serial communication link

The **LCL/RMT** button controls whether the WSIQ2 will respond to local control (via the keypad) or remote control (via the remote inputs).

- The Local LED on the keypad is on when the soft starter is in local control mode and off when the soft starter is in remote control mode.
- The Remote LED on the WSIQ2 is on when the soft starter is in Remote mode and off when in Local mode. The Remote LED is located on the main body of the starter (behind the keypad) and is only visible if the keypad is remotely mounted.

Control via the fieldbus communication network is always enabled in local control mode, and can be enabled or disabled in remote control mode (parameter 6R *Comms in Remote*). Control via the serial communication network requires an optional communication module.

The **STOP** button on the keypad is always enabled.

Using the Soft Starter to Control a Motor

To soft start the motor, press the **START** button on the keypad or activate the Start remote input. The motor will start using the start mode selected in parameter 2A.

To stop the motor, press the **STOP** button on the keypad or activate the Stop remote input. The motor will stop using the stop mode selected in parameter 2H.

To reset a trip on the soft starter, press the **RESET** button on the keypad or activate the Reset remote input.

To stop the motor with a coast to stop, regardless of the setting of parameter 2H *Stop Mode*, press the local **STOP** and **RESET** buttons at the same time. The soft starter will remove power from the motor and open the main contactor, and the motor will coast to stop.

Auto-Start/Stop

The WSIQ2 can also be configured to auto-start or auto-stop. Auto-start/stop operation is only available in Remote mode. In Local mode, the starter will ignore any auto-start/stop setting. To configure auto-start/stop operation, use parameters 3A~3D.

10.3 Soft Start Methods

Soft starters offer a variety of methods to control motor starting. Each soft start method uses a different primary control parameter.

Soft Start Method	Parameter Controlled	Performance Parameters Influenced
Timed Voltage Ramp	Voltage	Start current, start torque, acceleration
Constant Current	Current	Start torque, acceleration
Torque Control	Torque	Start current, acceleration
Adaptive Control	Acceleration	Start current, start torque

Best results are obtained by selecting the soft start method that directly controls the parameter of most importance for the application. Typically soft starters are used to limit motor start current or control load acceleration and/or deceleration. The WSIQ2 can be set to either Constant Current or Adaptive Control.

To Control	Use
Motor Start Current	Constant Current
Motor/Load Acceleration	Adaptive Control

Constant Current

Constant current is the traditional form of soft starting, which raises the current from zero to a specified level and keeps the current stable at that level until the motor has accelerated.

Constant current starting is ideal for applications where the start current must be kept below a particular level.

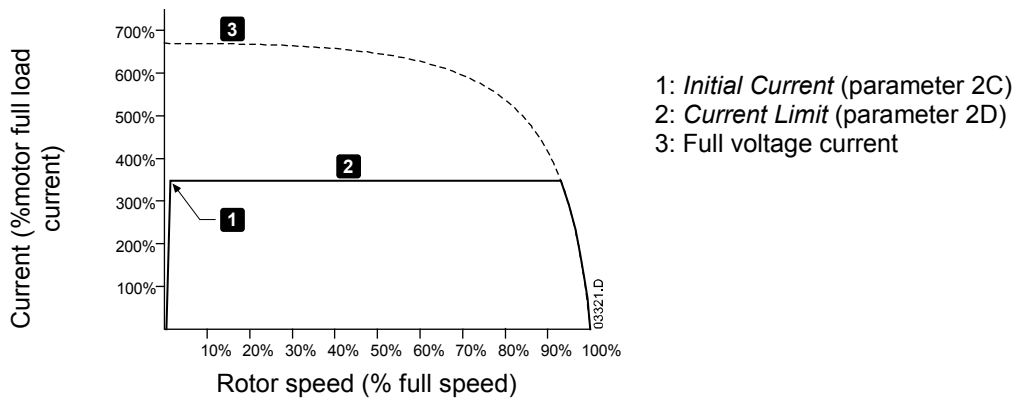

Current Ramp

Current ramp soft starting raises the current from a specified starting level (1) to a maximum limit (3), over an extended period of time (2).

Current ramp starting can be useful for applications where:

- the load can vary between starts (for example a conveyor which may start loaded or unloaded). Set the initial current (parameter 2C) to a level that will start the motor with a light load, and the current limit (parameter 2D) to a level that will start the motor with a heavy load.
- the load breaks away easily, but starting time needs to be extended (for example a centrifugal pump where pipeline pressure needs to build up slowly).
- the electricity supply is limited (for example a generator set), and a slower application of load will allow greater time for the supply to respond.

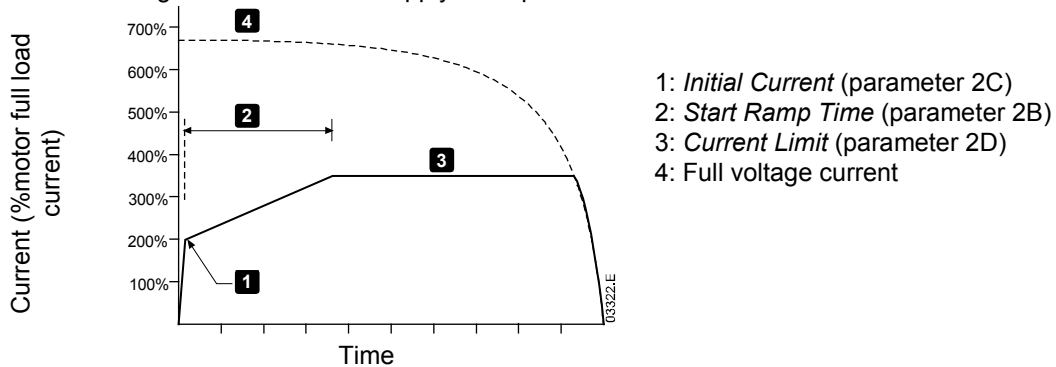

Adaptive Control for Starting

In an adaptive control soft start, the WSIQ2 adjusts the current in order to start the motor within a specified time and using a selected acceleration profile.



CAUTION

Adaptive Control cannot start the motor faster than a direct on-line (DOL) start. If the start ramp time (parameter 2B) is shorter than the motor's DOL start time, starting current may reach DOL levels.

Every application has a particular starting profile, based on characteristics of the load and the motor. Adaptive Control offers three different starting profiles, to suit the requirements of different applications. Selecting a profile that matches the inherent profile of the application can help smooth out acceleration across the full start time. Selecting a dramatically different Adaptive Control profile can somewhat neutralise the inherent profile.

The WSIQ2 monitors the motor's performance during each start, to improve control for future soft starts.

• **Adaptive Control**

To use Adaptive Control to control starting performance:

1. Select Adaptive Control from the Start Mode menu (parameter 2A)
2. Set the desired Start Ramp Time (parameter 2B)
3. Select the desired Adaptive Start Profile (parameter 2E)
4. Set a start Current Limit (parameter 2D) sufficiently high to allow a successful start. The first Adaptive Control start will be a Constant Current start. This allows the WSIQ2 to learn the characteristics of the connected motor. This motor data is used by the WSIQ2 during subsequent Adaptive Control starts.

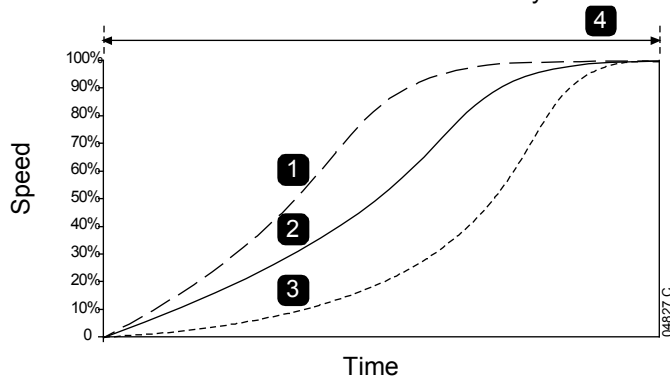

Adaptive Start Profile (parameter 2E):

1. Early Acceleration
2. Constant Acceleration
3. Late Acceleration
4. *Start Ramp Time* (parameter 2B)



NOTE

Adaptive Control will control the load according to the programmed profile. Start current will vary according to the selected acceleration profile and the programmed start time.

If replacing a motor connected to an WSIQ2 programmed for Adaptive Control starting or stopping, or if the starter has been tested on a different motor prior to actual installation, the starter will need to learn the characteristics of the new motor. The WSIQ2 will automatically re-learn the motor's characteristics if parameter 1A *Motor Full Load Current* or parameter 2K *Adaptive Control Gain* is changed.

• **How to Select the Adaptive Control Start Profile**

The best profile will depend on the exact details of each application.

Some loads, such as submersible pumps, should not be run at slow speeds. An early acceleration profile will raise the speed quickly, then control acceleration through the rest of the start.



CAUTION

Adaptive Control controls the motor's speed profile, within the programmed time limit. This may result in a higher level of current than traditional control methods.

• **Fine-tuning Adaptive Control**

If the motor does not start or stop smoothly, adjust the adaptive control gain (parameter 2K). The gain setting determines how much the WSIQ2 will adjust future adaptive control starts and stops, based on information from the previous start. The gain setting affects both starting and stopping performance.

- If the motor accelerates or decelerates too quickly at the end of a start or stop, increase the gain setting by 5%~10%.
- If the motor speed fluctuates during starting or stopping, decrease the gain setting slightly.



NOTE

Changing the gain setting resets the starter's adaptive control learning. The first start after changing the gain will use constant current.

Kickstart

Kickstart provides a short boost of extra torque at the beginning of a start, and can be used in conjunction with current ramp or constant current starting.

Kickstart can be useful to help start loads that require high breakaway torque but then accelerate easily (for example helical rotor pumps).

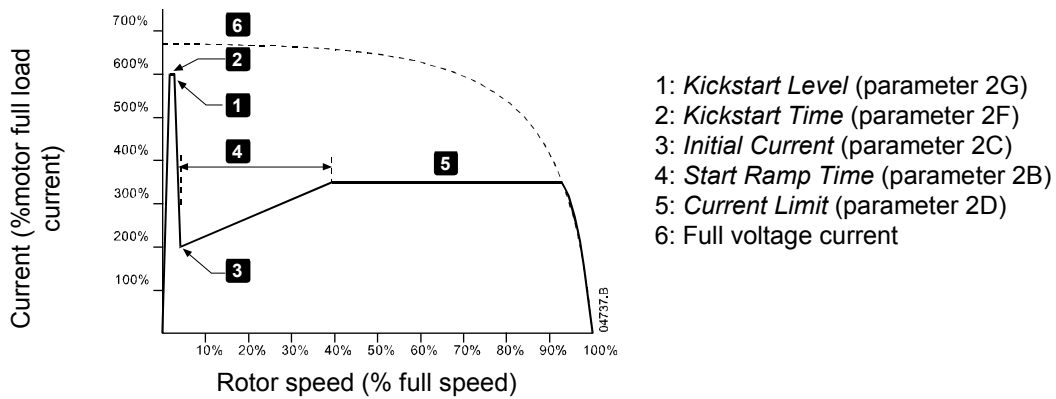

10.4 Stop Methods

Soft starters offer a variety of methods for the control of motor stopping.

Stop Method	Performance Result
Coast To Stop	Natural load run down
TVR Soft Stop	Extended run down time
Adaptive Control	Extended run down time according to selected deceleration profile
Brake	Reduced run down time

Soft starters are often used in pumping applications to eliminate the damaging effects of fluid hammer. Adaptive Control should be the preferred stop method for these applications.

Coast to Stop

Coast to stop lets the motor slow at its natural rate, with no control from the soft starter. The time required to stop will depend on the type of load.

TVR Soft Stop

Timed voltage ramp reduces the voltage to the motor gradually over a defined time. The load may continue to run after the stop ramp is complete.

Timed voltage ramp stopping can be useful for applications where the stop time needs to be extended, or to avoid transients on generator set supplies.

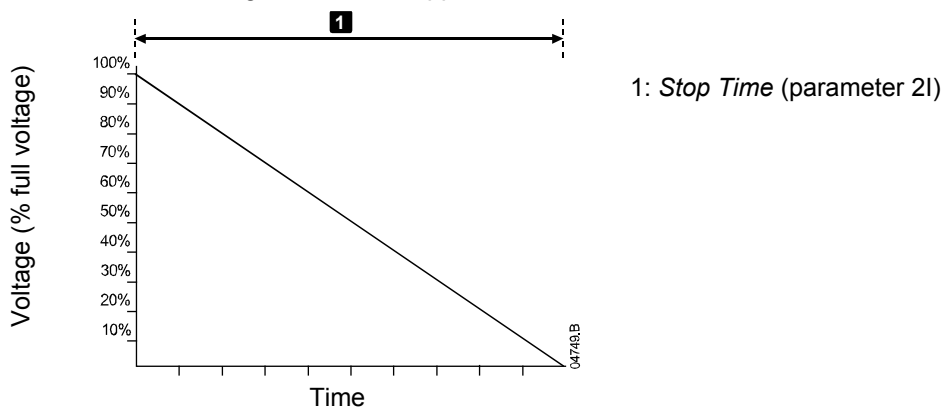

Adaptive Control for Stopping

In an adaptive control soft stop, the WSIQ2 controls the current in order to stop the motor within a specified time and using a selected deceleration profile. Adaptive Control can be useful in extending the stopping time of low inertia loads.

Every application has a particular stopping profile, based on characteristics of the load and the motor. Adaptive Control offers three different stopping profiles. Choose the adaptive control profile that best matches your application requirements.



NOTE

Adaptive control does not actively slow the motor down and will not stop the motor faster than a coast to stop. To shorten the stopping time of high inertia loads, use brake.



CAUTION

Adaptive Control controls the motor's speed profile, within the programmed time limit. This may result in a higher level of current than traditional control methods.

• **Adaptive Control**

To use Adaptive Control to control stopping performance:

1. Select Adaptive Control from the Stop Mode menu (parameter 2H)
2. Set the desired Stop Time (parameter 2I)
3. Select the required Adaptive Stop Profile (parameter 2J)

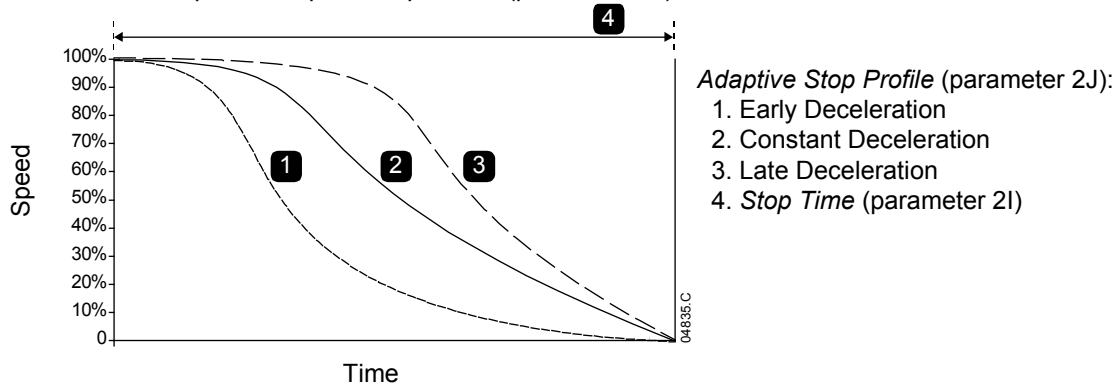

The first Adaptive Control stop will be a normal soft stop. This allows the WSIQ2 to learn the characteristics of the connected motor. This motor data is used by the WSIQ2 during subsequent Adaptive Control stops.



NOTE

Adaptive Control will control the load according to the programmed profile. Stopping current will vary according to the selected deceleration profile and stop time.

If replacing a motor connected to an WSIQ2 programmed for Adaptive Control starting or stopping, or if the starter has been tested on a different motor prior to actual installation, the starter will need to learn the characteristics of the new motor. The WSIQ2 will automatically re-learn the motor's characteristics if parameter 1A *Motor Full Load Current* or parameter 2K *Adaptive Control Gain* is changed.

• **Pump stopping**

The hydraulic characteristics of pump systems vary considerably. This variation means the ideal deceleration profile and stop time will vary from application to application. The table provides guidelines on selecting between Adaptive Control deceleration profiles, but we recommend testing the three profiles to identify the best profile for the application.

Adaptive Stop Profile	Application
Late Deceleration	High head systems where even a small decrease in motor/pump speed results in a rapid transition between forward flow and reverse flow.
Constant Deceleration	Low to medium head, high flow applications where the fluid has high momentum.
Early Deceleration	Open pump systems where fluid must drain back through the pump without driving the pump in reverse.

Brake

Brake reduces the time required to stop the motor.

During braking an increased noise level from the motor may be audible. This is a normal part of motor braking.

When brake is selected, the WSIQ2 uses DC injection to slow the motor.

WSIQ2 braking:

- Does not require the use of a DC brake contactor
- Controls all three phases so that the braking currents and associated heating are evenly distributed through the motor.



CAUTION

If the brake torque is set too high, the motor will stop before the end of the brake time and the motor will suffer unnecessary heating which could result in damage. Careful configuration is required to ensure safe operation of the starter and motor.

A high brake torque setting can result in peak currents up to motor DOL being drawn while the motor is stopping. Ensure protection fuses installed in the motor branch circuit are selected appropriately.



CAUTION

Brake operation causes the motor to heat faster than the rate calculated by the motor thermal model. If you are using brake, install a motor thermistor or allow sufficient restart delay (parameter 4M).

Braking has two stages:

- Pre-brake: provides an intermediate level of braking to slow motor speed to a point where full brake can be operated successfully (approximately 70% speed).
- Full brake: brake provides maximum braking torque but is ineffective at speeds greater than approximately 70%.

To configure the WSIQ2 for brake operation:

1. Set parameter 2I for the desired stopping time duration (1). This is the total braking time and must be set sufficiently longer than the brake time (parameter 2M) to allow the pre-braking stage to reduce motor speed to approximately 70%. If the stop time is too short, braking will not be successful and the motor will coast to stop.
2. Set Brake Time (parameter 2M) to approximately one quarter of the programmed Stop Time. This sets the time for the Full Brake stage (2).
3. Adjust the Brake Torque (parameter 2L) so that the desired stopping performance is achieved. If set too low, the motor will not stop completely and will coast to stop by the end of the braking period.

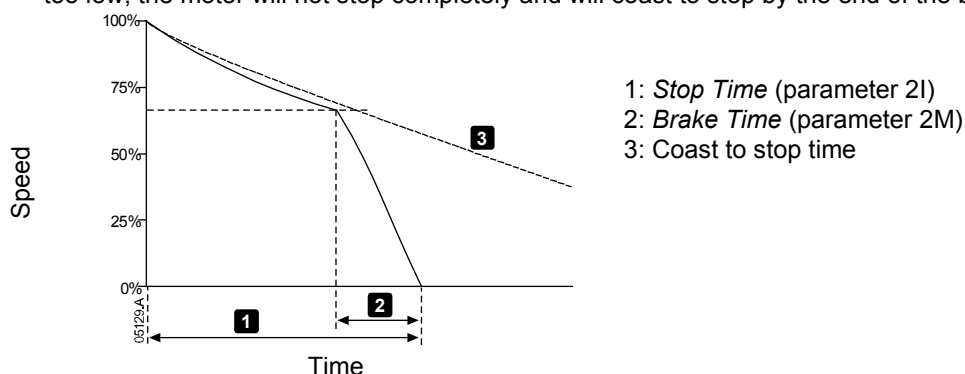

CAUTION

When using DC brake, the mains supply must be connected to the soft starter (input terminals L1, L2, L3) in positive phase sequence and parameter 4G *Phase Sequence* must be set to Positive Only.



NOTE

For loads which may vary between braking cycles, install a zero speed sensor to ensure that the soft starter ends DC braking when the motor stops. This avoids unnecessary heating of the motor.

For more information on using the WSIQ2 with an external speed sensor (eg for applications with variable load during the braking cycle), refer to *DC Brake with External Zero Speed Sensor* on page 62.

10.5 Jog Operation

Jog runs the motor at reduced speed, to allow alignment of the load or to assist servicing. The motor can be jogged in either forward or reverse direction.



CAUTION

Slow speed running is not intended for continuous operation due to reduced motor cooling.

Jog operation causes the motor to heat faster than the rate calculated by the motor thermal model. If you are using jog, install a motor thermistor or allow sufficient restart delay (parameter 4M).



NOTE

Soft start and soft stop are not available during jog operation.

Jog is only available for the primary motor.

The maximum available torque for jog forward is approximately 50%~75% of motor full load torque (FLT) depending on the motor. The torque when the motor is jogged in reverse is approximately 25% to 50% of FLT.

Parameter 15E *Jog Torque* controls how much of the maximum available jog torque the soft starter will apply to the motor.



NOTE

Torque settings above 50% may cause increased shaft vibration.

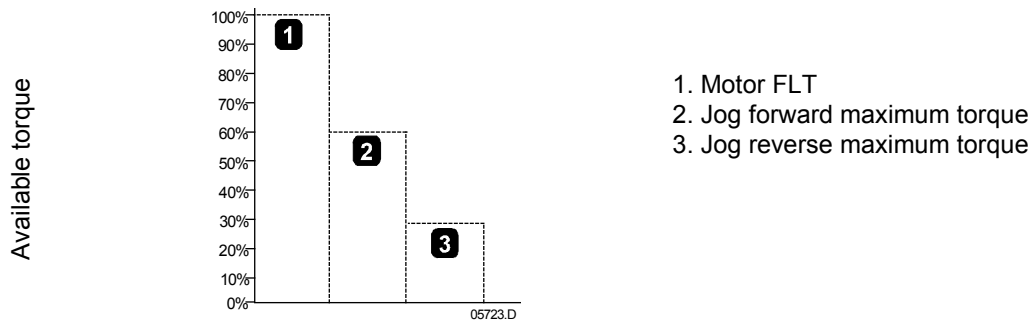

To activate jog operation, use either a programmable input (refer to parameters 6A and 6F, will operate only in Remote Mode) or a shortcut key (parameters 8B and 8C).

To stop a jog operation, perform one of the following:

- Remove the jog command.
- Press the **STOP** button on the keypad.

Jog will recommence at the end of a restart delay if the jog command is still present. All other commands except the above, will be ignored during jog operation.

10.6 Inside Delta Operation

Adaptive Control, Jog, Brake and PowerThrough functions are not supported with inside delta (six-wire) operation. If these functions are programmed when the starter is connected inside delta the behaviour is as given below:

Adaptive Control Start	The starter performs a constant current start.
Adaptive Control Stop	The starter performs a TVR soft stop if parameter 2I <i>Stop Time</i> is >0 secs. If parameter 2I is set to 0 secs the starter performs a coast to stop.
Jog	The starter issues a warning with the error message Unsupported Option.
Brake	The starter performs a coast to stop.
PowerThrough	The starter trips with the error message Lx-Tx Shorted.



NOTE

When connected in inside delta, current imbalance is the only phase loss protection that is active during run. Do not disable current imbalance protection (parameter 4H) during inside delta operation.



NOTE

When connecting in inside delta, enter the motor full load current (FLC) for parameter 1A. The WSIQ2 will automatically detect whether the motor is connected in-line or inside delta and will calculate the correct inside delta current level.

11 Programming Menu

You can access the Programming Menu at any time, including while the soft starter is running. Any changes to the start profile take effect immediately.

The Programming Menu contains four sub-menus:

- Quick Setup** Quick Setup guides you through the parameters required to configure the WSIQ2 for common applications. Quick Setup suggests a value for each parameter, but you can change these as required.
- Standard Menu** The Standard Menu provides access to commonly used parameters, allowing you to configure the WSIQ2 to suit your application.
- Extended Menu** The Extended Menu provides access to all the WSIQ2's programmable parameters, allowing experienced users to take advantage of advanced features.
- Load/Save Settings** Load/Save Settings lets you save the current parameter settings to a file, load parameters from a previously saved file, or reset all parameters to default values.

11.1 Programming Menu

The Programming Menu lets you view and change programmable parameters that control how the WSIQ2 operates.

To open the Programming Menu, press the **MENU/ENTER** button while viewing the monitoring screens.

To navigate through the Programming Menu:

- to scroll through parameter groups, press the ▲ or ▼ button.
- to open a submenu, press the ► button.
- to view the parameters in a group, press the ► button.
- to return to the previous level, press the ◀ button.
- to close the Programming Menu, press ◀ repeatedly.

To change a parameter value:

- scroll to the appropriate parameter in the Programming Menu and press **ENTER/MENU** to enter edit mode.
- to alter the parameter setting, use the ▲ and ▼ buttons. Pressing ▲ or ▼ once will increase or decrease the value by one unit. If the button is held for longer than five seconds, the value will increase or decrease at a faster rate.
- to save changes, press **ENTER**. The setting shown on the display will be saved and the keypad will return to the parameter list.
- to cancel changes, press **EXIT**. The keypad will ask for confirmation, then return to the parameter list without saving changes.

11.2 Adjustment Lock

You can lock the Programming Menu to prevent users from altering parameter settings. The adjustment lock can be turned on and off using parameter 15B.

To lock the programming menu:

1. Open the Programming Menu.
2. Open the Extended Menu.
3. Select 'Advanced'.
4. Enter the Access Code.
5. Select parameter 15B *Adjustment Lock*
6. Select and store 'Read Only'.

If a user attempts to change a parameter value when the adjustment lock is active, an error message is displayed:

<p style="text-align: center;">Access Denied Adj Lock is On</p>

11.3 Access Code

Critical parameters (parameter group 15 and higher) are protected by a four-digit security access code, preventing unauthorised users from viewing or modifying parameter settings.

When a user attempts to enter a restricted parameter group, the keypad prompts for an access code. The access code is requested once for the programming session, and authorisation continues until the user closes the menu.

To enter the access code, use the ◀ and ▶ buttons to select a digit, and the ▲ and ▼ buttons to change the value. When all four digits match your access code, press **STORE**. The keypad will display an acknowledgement message before continuing.

Enter Access Code 0###	STORE
Access Allowed SUPERVISOR	

To change the access code, use parameter 15A.

The simulation tools and counter resets are also protected by the security access code.

The default access code is 0000.

11.4 Quick Setup

The Quick Setup Menu makes it easy to configure the WSIQ2 for common applications. The WSIQ2 selects the parameters relevant to the application and suggests a typical setting, and you can adjust each parameter to suit your exact requirements.

Always set parameter 1A *Motor Full Load Current* to match the motor's nameplate full load current. The suggested value is the starter's minimum full load current.

On the display, the highlighted values are suggested values and the values indicated by a ▶ are the loaded values.

Application	Parameter	Suggested value
Pump Centrifugal	<i>Motor Full Load Current</i> <i>Start Mode</i> <i>Adaptive Start Profile</i> <i>Start Ramp Time</i> <i>Stop Mode</i> <i>Adaptive Stop Profile</i> <i>Stop Time</i>	Model dependent Adaptive Control Early Acceleration 10 seconds Adaptive Control Late Deceleration 15 seconds
Pump Submersible	<i>Motor Full Load Current</i> <i>Start Mode</i> <i>Adaptive Start Profile</i> <i>Start Ramp Time</i> <i>Stop Mode</i> <i>Adaptive Stop Profile</i> <i>Stop Time</i>	Model dependent Adaptive Control Early Acceleration 5 seconds Adaptive Control Late Deceleration 5 seconds
Fan Damped	<i>Motor Full Load Current</i> <i>Start Mode</i> <i>Current Limit</i>	Model dependent Constant Current 350%
Fan Undamped	<i>Motor Full Load Current</i> <i>Start Mode</i> <i>Adaptive Start Profile</i> <i>Start Ramp Time</i> <i>Excess Start Time</i> <i>Locked Rotor Time</i>	Model dependent Adaptive Control Constant Acceleration 20 seconds 30 seconds 20 seconds
Compressor Screw	<i>Motor Full Load Current</i> <i>Start Mode</i> <i>Start Ramp Time</i> <i>Current Limit</i>	Model dependent Constant Current 5 seconds 400%
Compressor Recip	<i>Motor Full Load Current</i> <i>Start Mode</i> <i>Start Ramp Time</i> <i>Current Limit</i>	Model dependent Constant Current 5 seconds 450%
Conveyor	<i>Motor Full Load Current</i> <i>Start Mode</i>	Model dependent Constant Current

	<i>Start Ramp Time</i> <i>Current Limit</i> <i>Stop Mode</i> <i>Adaptive Stop Profile</i> <i>Stop Time</i>	5 seconds 400% Adaptive Control Constant Deceleration 10 seconds
Crusher Rotary	<i>Motor Full Load Current</i> <i>Start Mode</i> <i>Start Ramp Time</i> <i>Current Limit</i> <i>Excess Start Time</i> <i>Locked Rotor Time</i>	Model dependent Constant Current 10 seconds 400% 30 seconds 20 seconds
Crusher Jaw	<i>Motor Full Load Current</i> <i>Start Mode</i> <i>Start Ramp Time</i> <i>Current Limit</i> <i>Excess Start Time</i> <i>Locked Rotor Time</i>	Model dependent Constant Current 10 seconds 450% 40 seconds 30 seconds

11.5 Standard Menu

The standard menu provides access to commonly used parameters, allowing the user to configure the WSIQ2 as required for the application. For details of individual parameters, refer to *Parameter Descriptions* on page 40.

		Parameter Group	Default Setting
1	Motor Data-1		
	1A	<i>Motor Full Load Current</i>	Model dependent
2	Start/Stop Modes-1		
	2A	<i>Start Mode</i>	Constant Current
	2B	<i>Start Ramp Time</i>	10s
	2C	<i>Initial Current</i>	350%
	2D	<i>Current Limit</i>	350%
	2H	<i>Stop Mode</i>	Coast To Stop
	2I	<i>Stop Time</i>	0s
3	Auto-Start/Stop		
	3A	<i>Auto-Start Type</i>	Off
	3B	<i>Auto-Start Time</i>	1m
	3C	<i>Auto-Stop Type</i>	Off
	3D	<i>Auto-Stop Time</i>	1m
4	Protection Settings		
	4A	<i>Excess Start Time</i>	20s
	4C	<i>Undercurrent</i>	20%
	4D	<i>Undercurrent Delay</i>	5s
	4E	<i>Instantaneous Overcurrent</i>	400%
	4F	<i>Instantaneous Overcurrent Delay</i>	0s
	4G	<i>Phase Sequence</i>	Any Sequence
6	Inputs		
	6A	<i>Input A Function</i>	Motor Set Select
	6B	<i>Input A Name</i>	Input Trip
	6C	<i>Input A Trip</i>	Always Active
	6D	<i>Input A Trip Delay</i>	0s
	6E	<i>Input A Initial Delay</i>	0s
	6F	<i>Input B Function</i>	Input Trip (N/O)
	6G	<i>Input B Name</i>	Input Trip
	6H	<i>Input B Trip</i>	Always Active
	6I	<i>Input B Trip Delay</i>	0s
	6J	<i>Input B Initial Delay</i>	0s
7	Outputs		
	7A	<i>Relay A Function</i>	Main Contactor
	7B	<i>Relay A On Delay</i>	0s
	7C	<i>Relay A Off Delay</i>	0s
	7D	<i>Relay B Function</i>	Run

	7E	<i>Relay B On Delay</i>	0s
	7F	<i>Relay B Off Delay</i>	0s
	7G	<i>Relay C Function</i>	Trip
	7H	<i>Relay C On Delay</i>	0s
	7I	<i>Relay C Off Delay</i>	0s
	7M	<i>Low Current Flag</i>	50%
	7N	<i>High Current Flag</i>	100%
	7O	<i>Motor Temperature Flag</i>	80%
8	Display		
	8A	<i>Language</i>	English
	8B	<i>F1 Button Action</i>	Auto-Start/Stop Menu
	8C	<i>F2 Button Action</i>	None
	8D	<i>Display A or kW</i>	Current
	8E	<i>User Screen - Top Left</i>	Starter State
	8F	<i>User Screen - Top Right</i>	Blank
	8G	<i>User Screen - Bottom Left</i>	Hours Run
	8H	<i>User Screen - Bottom Right</i>	Analog Input

11.6 Extended Menu

The Extended Menu provides access to all the WSIQ2's programmable parameters.

		Parameter Group	Default Setting
1	Motor Data-1		
	1A	<i>Motor Full Load Current</i>	Model dependent
	1B	<i>Locked Rotor Time</i>	0m:10s
	1C	<i>Locked Rotor Current</i>	600%
	1D	<i>Motor Service Factor</i>	105%
2	Start/Stop Modes-1		
	2A	<i>Start Mode</i>	Constant Current
	2B	<i>Start Ramp Time</i>	10 s
	2C	<i>Initial Current</i>	350%
	2D	<i>Current Limit</i>	350%
	2E	<i>Adaptive Start Profile</i>	Constant Acceleration
	2F	<i>Kickstart Time</i>	0000ms
	2G	<i>Kickstart Level</i>	500%
	2H	<i>Stop Mode</i>	Coast To Stop
	2I	<i>Stop Time</i>	0m:00s
	2J	<i>Adaptive Stop Profile</i>	Constant Deceleration
	2K	<i>Adaptive Control Gain</i>	75%
	2L	<i>Brake Torque</i>	20%
	2M	<i>Brake Time</i>	0m:01s
3	Auto-Start/Stop		
	3A	<i>Auto-Start Type</i>	Off
	3B	<i>Auto-Start Time</i>	00h:01m
	3C	<i>Auto-Stop Type</i>	Off
	3D	<i>Auto-Stop Time</i>	00h:01m
4	Protection Settings		
	4A	<i>Excess Start Time</i>	0m:20s
	4B	<i>Excess Start Time-2</i>	0m:20s
	4C	<i>Undercurrent</i>	20%
	4D	<i>Undercurrent Delay</i>	0m:05s
	4E	<i>Instantaneous Overcurrent</i>	400%
	4F	<i>Instantaneous Overcurrent Delay</i>	0m:00s
	4G	<i>Phase Sequence</i>	Any Sequence
	4H	<i>Current Imbalance</i>	30%
	4I	<i>Current Imbalance Delay</i>	0m:03s
	4J	<i>Frequency Check</i>	Start/Run
	4K	<i>Frequency Variation</i>	± 5Hz
	4L	<i>Frequency Delay</i>	0m:01s

4M	<i>Restart Delay</i>	10s
4N	<i>Motor Temperature Check</i>	Do Not Check
4O	<i>Ground Fault Level</i>	100 mA
4P	<i>Ground Fault Delay</i>	0m:03s
4Q	<i>Reserved</i>	-
4R	<i>Reserved</i>	-
4S	<i>Reserved</i>	-
4T	<i>Reserved</i>	-
5	Auto-Reset Trips	
5A	<i>Auto-Reset Action</i>	Do Not Auto-Reset
5B	<i>Maximum Resets</i>	1
5C	<i>Reset Delay Groups A&B</i>	00m:05s
5D	<i>Reset Delay Group C</i>	05 m
6	Inputs	
6A	<i>Input A Function</i>	Motor Set Select
6B	<i>Input A Name</i>	Input Trip
6C	<i>Input A Trip</i>	Always Active
6D	<i>Input A Trip Delay</i>	0m:00s
6E	<i>Input A Initial Delay</i>	0m:00s
6F	<i>Input B Function</i>	Input Trip (N/O)
6G	<i>Input B Name</i>	Input Trip
6H	<i>Input B Trip</i>	Always Active
6I	<i>Input B Trip Delay</i>	0m:00s
6J	<i>Input B Initial Delay</i>	00m:00s
6K	<i>Input C Function</i>	Off
6L	<i>Input D Function</i>	Off
6M	<i>Remote Reset Logic</i>	Normally Closed
6N	<i>Analog Input Trip</i>	Do Not Trip
6O	<i>Analog Input Scale</i>	2-10 V
6P	<i>Analog Trip Point</i>	50%
6Q	<i>Local/Remote</i>	LCL/RMT Anytime
6R	<i>Comms in Remote</i>	Enable Control in RMT
7	Outputs	
7A	<i>Relay A Function</i>	Main Contactor
7B	<i>Relay A On Delay</i>	0m:00s
7C	<i>Relay A Off Delay</i>	0m:00s
7D	<i>Relay B Function</i>	Run
7E	<i>Relay B On Delay</i>	0m:00s
7F	<i>Relay B Off Delay</i>	0m:00s
7G	<i>Relay C Function</i>	Trip
7H	<i>Relay C On Delay</i>	0m:00s
7I	<i>Relay C Off Delay</i>	0m:00s
7J	<i>Relay D Function</i>	Off
7K	<i>Relay E Function</i>	Off
7L	<i>Relay F Function</i>	Off
7M	<i>Low Current Flag</i>	50%
7N	<i>High Current Flag</i>	100%
7O	<i>Motor Temperature Flag</i>	80%
7P	<i>Analog Output A</i>	Current (% FLC)
7Q	<i>Analog A Scale</i>	4-20 mA
7R	<i>Analog A Maximum Adjustment</i>	100%
7S	<i>Analog A Minimum Adjustment</i>	000%
7T	<i>Analog Output B</i>	Current (% FLC)
7U	<i>Analog B Scale</i>	4-20 mA
7V	<i>Analog B Maximum Adjustment</i>	100%
7W	<i>Analog B Minimum Adjustment</i>	000%
8	Display	
8A	<i>Language</i>	English

8B	<i>F1 Button Action</i>	Auto-Start/Stop Menu
8C	<i>F2 Button Action</i>	None
8D	<i>Display A or kW</i>	Current
8E	<i>User Screen - Top Left</i>	Starter State
8F	<i>User Screen - Top Right</i>	Blank
8G	<i>User Screen - Bottom Left</i>	Hours Run
8H	<i>User Screen - Bottom Right</i>	Analog Input
8I	<i>Graph Data</i>	Current (% FLC)
8J	<i>Graph Timebase</i>	10s
8K	<i>Graph Maximum Adjustment</i>	400%
8L	<i>Graph Minimum Adjustment</i>	000%
8M	<i>Current Calibration</i>	100%
8N	<i>Mains Reference Voltage</i>	400 V
8O	<i>Voltage Calibration</i>	100%
9	Motor Data-2	
9A	<i>Dual Thermal Model</i>	Single
9B	<i>Motor FLC-2</i>	Model dependent
9C	<i>Locked Rotor Time-2</i>	0m:10s
9D	<i>Locked Rotor Current-2</i>	600%
9E	<i>Motor Service Factor-2</i>	105%
10	Start/Stop Modes-2	
10A	<i>Start Mode-2</i>	Constant Current
10B	<i>Start Ramp-2</i>	0m:10s
10C	<i>Initial Current-2</i>	350%
10D	<i>Current Limit-2</i>	350%
10E	<i>Adaptive Start Profile-2</i>	Constant Acceleration
10F	<i>Kickstart Time-2</i>	0000 ms
10G	<i>Kickstart Level-2</i>	500%
10H	<i>Stop Mode-2</i>	Coast To Stop
10I	<i>Stop Time-2</i>	0m:00s
10J	<i>Adaptive Stop Profile-2</i>	Constant Deceleration
10K	<i>Adaptive Control Gain-2</i>	75%
10L	<i>Brake Torque-2</i>	20%
10M	<i>Brake Time-2</i>	0m:01s
11	RTD Temperatures	
11A	<i>RTD/PT100 A °C</i>	50 °C (122 °F)
11B	<i>RTD/PT100 B °C</i>	50 °C (122 °F)
11C	<i>RTD/PT100 C °C</i>	50 °C (122 °F)
11D	<i>RTD/PT100 D °C</i>	50 °C (122 °F)
11E	<i>RTD/PT100 E °C</i>	50 °C (122 °F)
11F	<i>RTD/PT100 F °C</i>	50 °C (122 °F)
11G	<i>RTD/PT100 G °C</i>	50 °C (122 °F)
12	Slip-Ring Motors	
12A	<i>Motor Data-1 Ramp</i>	Single Ramp
12B	<i>Motor Data-2 Ramp</i>	Single Ramp
12C	<i>Changeover Time</i>	150 ms
12D	<i>Slip Ring Retard</i>	50%
15	Advanced (Requires Access Code. Default: 0000)	
15A	<i>Access Code</i>	0000
15B	<i>Adjustment Lock</i>	Read & Write
15C	<i>Emergency Run</i>	Disable
15D	<i>Shorted SCR Action</i>	3-Phase Control Only
15E	<i>Jog Torque</i>	50%
16	Protection Action	
16A	<i>Motor Overload</i>	Trip Starter
16B	<i>Excess Start Time</i>	Trip Starter
16C	<i>Undercurrent</i>	Trip Starter
16D	<i>Instantaneous Overcurrent</i>	Trip Starter

16E	<i>Current Imbalance</i>	Trip Starter
16F	<i>Frequency</i>	Trip Starter
16G	<i>Input A Trip</i>	Trip Starter
16H	<i>Input B Trip</i>	Trip Starter
16I	<i>Motor Thermistor</i>	Trip Starter
16J	<i>Starter Communication</i>	Trip Starter
16K	<i>Network Communication</i>	Trip Starter
16L	<i>Heatsink Overtemperature</i>	Trip Starter
16M	<i>Battery/Clock</i>	Trip Starter
16N	<i>Ground Fault</i>	Trip Starter
16O	<i>RTD/PT100 A</i>	Trip Starter
16P	<i>RTD/PT100 B</i>	Trip Starter
16Q	<i>RTD/PT100 C</i>	Trip Starter
16R	<i>RTD/PT100 D</i>	Trip Starter
16S	<i>RTD/PT100 E</i>	Trip Starter
16T	<i>RTD/PT100 F</i>	Trip Starter
16U	<i>RTD/PT100 G</i>	Trip Starter
16V	<i>Reserved</i>	-
16W	<i>Reserved</i>	-
16X	<i>Low Control Volts</i>	Trip Starter
20	Restricted	
	Factory Use Only	

11.7 Load/Save Settings

The Load/Save Settings menu requires an access code and allows users to:

- Load the WSIQ2's parameters with default values
- Load parameter settings from an internal file
- Save the current parameter settings to an internal file

In addition to the factory default values file, the WSIQ2 can store two user-defined parameter files. These files contain default values until a user file is saved.

To load or save parameter settings:

1. Open the Programming Menu.
2. Scroll to Load/Save Settings and press the **ENTER/MENU** button.
3. Scroll to the required function and press the **ENTER/MENU** button.
4. At the confirmation prompt, select YES to confirm or NO to cancel and then **STORE** to load/save the selection.

```

Load/Save Settings
Load Defaults
Load Backup
Load User Set 1
    
```

```

Load Defaults
No
Yes
    
```

When the action has been completed, the screen will briefly display a confirmation message, then return to the status screens.



NOTE

The saved files and current operating settings are stored in both the keypad and in the soft starter. The keypad will prompt you to synchronize the settings whenever it is plugged into a new WSIQ2.

11.8 Parameter Descriptions

1 Motor Data-1

The parameters in Motor Data-1 configure the soft starter to match the connected motor. These parameters describe the motor's operating characteristics and allow the soft starter to model the motor's temperature.



NOTE

When connecting in inside delta, enter the motor full load current (FLC) for parameter 1A. The WSIQ2 will automatically detect whether the motor is connected in-line or inside delta and will calculate the correct inside delta current level.

1A – Motor FLC

Range: Model dependent

Description: Matches the starter to the connected motor's full load current. Set to the full load current (FLC) rating shown on the motor nameplate.

1B – Locked Rotor Time

Range: 0:01 - 2:00 (minutes:seconds) **Default:** 10 seconds

Description: Sets the maximum length of time the motor can sustain locked rotor current from cold before reaching its maximum temperature. Set according to the motor datasheet.

1C – Locked Rotor Current

Range: 400% - 1200% FLC **Default:** 600%

Description: Sets the locked rotor current of the connected motor, as a percentage of full load current. Set according to the motor datasheet.

1D – Motor Service Factor

Range: 100% - 130% **Default:** 105%

Description: Sets the motor service factor used by the thermal model. If the motor runs at full load current, it will reach 100%. Set according to the motor datasheet.



NOTE

Parameters 1B, 1C and 1D determine the trip current for motor overload protection. The default settings of parameters 1B, 1C and 1D provide Motor Overload Protection: Class 10, Trip Current 105% of FLA (full load amperage) or equivalent.

2 Start/Stop Modes-1

2A – Start Mode

Options: Constant Current (default)
Adaptive Control

Description: Selects the soft start mode.

2B – Start Ramp Time

Range: 1 - 180 (seconds) **Default:** 10 seconds

Description: Sets the total start time for an Adaptive Control start or the ramp time for current ramp starting (from the initial current to the current limit).

2C – Initial Current

Range: 100% - 600% FLC **Default:** 350%

Description: Sets the initial start current level for current ramp starting, as a percentage of motor full load current. Set so that the motor begins to accelerate immediately after a start is initiated.
If current ramp starting is not required, set the initial current equal to the current limit.

2D – Current Limit

Range: 100% - 600% FLC **Default:** 350%

Description: Sets the current limit for constant current and current ramp soft starting, as a percentage of motor full load current.

2E – Adaptive Start Profile

Options:	Early Acceleration Constant Acceleration (default) Late Acceleration
Description:	Selects which profile the WSIQ2 will use for an Adaptive Control soft start.

2F – Kickstart Time

Range:	0 – 2000 milliseconds	Default:	0000 milliseconds
Description:	Sets the kickstart duration. A setting of 0 disables kickstart.		

2G – Kickstart Level

Range:	100% - 700% FLC	Default:	500%
Description:	Sets the level of the kickstart current.		

**CAUTION**

Kickstart subjects the mechanical equipment to increased torque levels. Ensure the motor, load and couplings can handle the additional torque before using this feature.

2H – Stop Mode

Options:	Coast To Stop (default) TVR Soft Stop Adaptive Control Brake
Description:	Selects the stop mode.

2I – Stop Time

Range:	0:00 - 4:00 (minutes:seconds)	Default:	0 seconds
Description:	Sets the time for soft stopping the motor using timed voltage ramp or Adaptive Control. This also sets the total stopping time when using brake. If a main contactor is installed, the contactor must remain closed until the end of the stop time. Use one of the programmable relays to control the main contactor.		

2J – Adaptive Stop Profile

Options:	Early Deceleration Constant Deceleration (default) Late Deceleration
Description:	Selects which profile the WSIQ2 will use for an Adaptive Control soft stop.

2K – Adaptive Control Gain

Range:	1% - 200%	Default:	75%
Description:	Adjusts the performance of Adaptive Control. This setting affects both starting and stopping control.		

**NOTE**

We recommend leaving the gain setting at the default level unless performance is not satisfactory. If the motor accelerates or decelerates too quickly at the end of a start or stop, increase the gain setting by 5%~10%. If the motor speed fluctuates during starting or stopping, decrease the gain setting slightly.

2L – Brake Torque

Range:	20% - 100%	Default:	20%
Description:	Sets the amount of brake torque the WSIQ2 will use to slow the motor.		

2M – Brake Time

Range:	1 - 30 (seconds)	Default:	1 second
Description:	Sets the duration for DC injection during a braking stop.		

**NOTE**

Parameter 2M is used in conjunction with parameter 2I. Refer to *Brake* for details.

3 Auto-Start/Stop

The WSIQ2 can be programmed to start and stop automatically, after a specified delay or at a specified time of day. Auto-start and auto-stop can be set separately.

Auto-start/stop operation is only available in Remote mode. In Local mode, the starter will ignore any auto-start/stop setting.



CAUTION

The auto-start timer overrides any other form of control. The motor may start without warning.



WARNING

This function should not be used in conjunction with remote two-wire control. The soft starter will still accept start and stop commands from the remote inputs or serial communication network. To disable local or remote control, use parameter 6Q. If auto-start is enabled and the user is in the menu system, auto-start will become active if the menu times out (if no keypad activity is detected for five minutes).

3A – Auto-Start Type

Options:	Off (default) Timer	The soft starter will not auto-start.
	Clock	The soft starter will auto-start after a delay from the next stop, as specified in parameter 3B. The soft starter will auto-start at the time programmed in parameter 3B.
Description:	Selects whether the soft starter will auto-start after a specified delay, or at a time of day.	

3B – Auto-Start Time

Range:	00:01 - 24:00 (hours:minutes)	Default: 1 minute
Description:	Sets the time for the soft starter to auto-start, in 24 hour clock format.	

3C – Auto-Stop Type

Options:	Off (default) Timer	The soft starter will not auto-stop.
	Clock	The soft starter will auto-stop after a delay from the next start, as specified in parameter 3D. The soft starter will auto-stop at the time programmed in parameter 3D.
Description:	Selects whether the soft starter will auto-stop after a specified delay, or at a time of day.	

3D – Auto-Stop Time

Range:	00:01 - 24:00 (hours:minutes)	Default: 1 minute
Description:	Sets the time for the soft starter to auto-stop, in 24 hour clock format.	

4 Protection Settings

These parameters determine when the soft starter's protection mechanisms will activate. The activation point for each protection mechanism can be set to suit the installation.

The soft starter responds to protection events by tripping, warning, or writing the event to the event log. The response is determined by the Protection Action settings. The default response is a trip.



CAUTION

The protection settings are vital for safe operation of the soft starter and motor. Defeating the protection may compromise the installation and should only be done in the case of emergency.

4A, 4B – Excess Start Time

Excess start time is the maximum time the WSIQ2 will attempt to start the motor. If the motor does not transition to Run mode within the programmed limit, the starter will trip. Set for a period slightly longer than required for a normal healthy start. A setting of 0 disables excess start time protection.

Range: 0:00 - 4:00 (minutes:seconds) **Default:** 20 seconds

Description: Parameter 4A sets the time for the primary motor and parameter 4B (*Excess Start Time-2*) sets the time for the secondary motor.

4C – Undercurrent

Range: 0% - 100% **Default:** 20%

Description: Sets the trip point for undercurrent protection, as a percentage of motor full load current. Set to a level between the motor's normal working range and the motor's magnetising (no load) current (typically 25% to 35% of full load current). A setting of 0% disables undercurrent protection.

4D – Undercurrent Delay

Range: 0:00 - 4:00 (minutes:seconds) **Default:** 5 seconds

Description: Slows the WSIQ2's response to undercurrent, avoiding trips due to momentary fluctuations.

4E – Instantaneous Overcurrent

Range: 80% - 600% FLC **Default:** 400%

Description: Sets the trip point for instantaneous overcurrent protection, as a percentage of motor full load current.

4F – Instantaneous Overcurrent Delay

Range: 0:00 - 1:00 (minutes:seconds) **Default:** 0 second

Description: Slows the WSIQ2's response to overcurrent, avoiding trips due to momentary overcurrent events.

4G – Phase Sequence

Options: Any Sequence (default)
Positive Only
Negative Only

Description: Selects which phase sequences the soft starter will allow at a start. During its pre-start checks, the starter examines the sequence of the phases at its input terminals and trips if the actual sequence does not match the selected option.

4H – Current Imbalance

Range: 10% - 50% **Default:** 30%

Description: Sets the trip point for current imbalance protection.

4I – Current Imbalance Delay

Range: 0:00 - 4:00 (minutes:seconds) **Default:** 3 seconds

Description: Slows the WSIQ2's response to current imbalance, avoiding trips due to momentary fluctuations.

4J – Frequency Check

Options: Do Not Check
Start Only
Start/Run (default)
Run Only

Description: Determines when and if the starter will monitor for a frequency trip.

4K – Frequency Variation

Options: ± 2 Hz
 ± 5 Hz (default)
 ± 10 Hz
 ± 15 Hz

Description: Selects the soft starter's tolerance for frequency variation.

4L – Frequency Delay

Range: 0:01 - 4:00 (minutes:seconds) **Default:** 1 second

Description: Slows the WSIQ2's response to frequency disturbances, avoiding trips due to momentary fluctuations.

**NOTE**

If the mains frequency drops below 35 Hz or rises above 75 Hz, the starter will trip immediately.

**CAUTION**

Running a motor outside its specified frequency for long periods can cause damage and premature failure.

4M – Restart Delay

Range: 00:01 - 60:00 (minutes:seconds) **Default:** 10 seconds

Description: The WSIQ2 can be configured to force a delay between the end of a stop and the beginning of the next start. During the restart delay period, the display shows the time remaining before another start can be attempted.

**NOTE**

The restart delay is measured from the end of each stop. Changes to the restart delay setting take effect after the next stop.

4N – Motor Temperature Check

Options: Do Not Check (default)
 Check

Description: Selects whether the WSIQ2 will verify the motor has sufficient thermal capacity for a successful start. The soft starter compares the motor's calculated temperature with the temperature rise from the last motor start and only operates if the motor is cool enough to start successfully.

4O – Ground Fault Level

Range: 20 mA - 50 A (21 steps) **Default:** 100mA

Description: Sets the trip point for ground fault protection.

4P – Ground Fault Delay

Range: 0:01 - 4:00 (minutes:seconds) **Default:** 3 seconds

Description: Slows the WSIQ2's response to ground fault variation, avoiding trips due to momentary fluctuations.

**NOTE**

Ground fault protection is only available if the RTD/PT100 and ground fault protection card is fitted.

4Q – Reserved

This parameter is reserved for internal use.

4R – Reserved

This parameter is reserved for internal use.

4S – Reserved

This parameter is reserved for internal use.

4T – Reserved

This parameter is reserved for internal use.

5 Auto-Reset Trips

The WSIQ2 can be programmed to automatically reset certain trips, which can help minimise operating downtime. Trips are divided into three categories for auto-reset, depending on the risk to the soft starter:

Group	Trips
A	Current imbalance Phase Loss Power loss Frequency
B	Undercurrent Instantaneous overcurrent Input A trip Input B trip
C	Motor overload RTD/PT100 temperature trips Motor thermistor Heatsink overtemperature

Other trips cannot be automatically reset.

This function is ideal for remote installations using 2-wire control in Remote mode. If the 2-wire start signal is present after an auto-reset, the WSIQ2 will restart.

5A – Auto-Reset Action

- Options:** Do Not Auto-Reset (default)
Reset Group A
Reset Group A & B
Reset Group A, B & C
- Description:** Selects which trips can be auto-reset.

5B – Maximum Resets

- Range:** 1 - 5 **Default:** 1
- Description:** Sets how many times the soft starter will auto-reset, if it continues to trip. The reset counter increases by one each time the soft starter auto-resets, and decreases by one after each successful start/stop cycle.

5C – Reset Delay Groups A&B

- Range:** 00:05 - 15:00 (minutes:seconds) **Default:** 5 seconds
- Description:** Sets the delay before resetting Group A and Group B trips.

5D – Reset Delay Group C

- Range:** 5 - 60 (minutes) **Default:** 5 minutes
- Description:** Sets the delay before resetting Group C trips.

6 Inputs

The WSIQ2 has two programmable inputs, which allow remote control of the soft starter. If required, two extra inputs are available on the input/output expansion card.

6A – Input A Function

- Options:** Motor Set Select (default) The WSIQ2 can be configured with two separate sets of motor data. To use the secondary motor data, parameter 6A must be set to 'Motor Set Select' and C53, C54 must be closed when a start command is given. The WSIQ2 checks which motor data to use at a start, and will use that motor data for the entire start/stop cycle.
- Input Trip (N/O) Input A can be used to trip the soft starter. When parameter 6A is set to Input Trip (N/O), a closed circuit across C53, C54 trips the soft starter.
- Input Trip (N/C) When parameter 6A is set to Input Trip (N/C), an open circuit across C53, C54 trips the soft starter.

Local/Remote Select	Input A can be used to select between local and remote control, instead of using the LCL/RMT button on the keypad. When the input is open, the starter is in local mode and can be controlled via the keypad. When the input is closed, the starter is in remote mode. The START and LCL/RMT buttons are disabled, and the soft starter will ignore any Local/Remote select command from the serial communications network. To use Input A to select between local and remote control, parameter 6Q must be set to 'LCL/RMT Anytime' or 'LCL/RMT When Off'.
Emergency Run	In emergency run the soft starter continues to run until stopped, ignoring all trips and warnings (refer to parameter 15C for details). Closing the circuit across C53, C54 activates emergency run. Opening the circuit ends emergency run and the WSIQ2 stops the motor.
Starter Disable	The WSIQ2 can be disabled via the control inputs. An open circuit across C53, C54 will disable the starter. The WSIQ2 will not respond to start commands. If running, the soft starter will allow the motor to coast to stop, ignoring the soft stop mode set in parameter 2H.
Jog Forward	Activates jog operation in a forward direction (will operate only in Remote mode).
Jog Reverse	Activates jog operation in reverse direction (will operate only in Remote mode).

Description: Selects the function of Input A.

6B – Input A Name

Options:	Input Trip (default) Low Pressure High Pressure Pump Fault Low Level High Level	No Flow Starter Disable Controller PLC Vibration
-----------------	--	--

Description: Selects a message for the keypad to display when Input A is active.

6C – Input A Trip

Options:	Always Active (default) Operating Only Run Only	A trip can occur at any time when the soft starter is receiving power. A trip can occur while the soft starter is running, stopping or starting. A trip can only occur while the soft starter is running.
-----------------	---	---

Description: Selects when an input trip can occur.

6D – Input A Trip Delay

Range:	0:00 - 4:00 (minutes:seconds)	Default: 0 second
Description:	Sets a delay between the input activating and the soft starter tripping.	

6E – Input A Initial Delay

Range:	00:00 - 30:00 (minutes:seconds)	Default: 0 second
Description:	Sets a delay before an input trip can occur. The initial delay is counted from the time a start signal is received. The state of the input is ignored until the initial delay has elapsed.	

6F, 6G, 6H, 6I, 6J – Input B Trip

Parameters 6F~6J configure the operation of Input B, in the same way as parameters 6A~6E configure Input A. Refer to Input A for details.

- 6F *Input B Function* (Default: Input Trip (N/O))
- 6G *Input B Name* (Default: Input Trip)
- 6H *Input B Trip* (Default: Always Active)
- 6I *Input B Trip Delay* (Default: 0:00)
- 6J *Input B Initial Delay* (Default: 0:00)

6K, 6L – Inputs C and D

Parameters 6K and 6L select the function of Inputs C and D. Refer to parameter 6A for details. Inputs C and D are only available if the input/output expansion card has been installed.

Options: Motor Set Select
Local/Remote Select
Emergency Run
Starter Disable (N/C)
Off (default)

6M – Remote Reset Logic

Options: Normally Closed (default)
Normally Open

Description: Selects whether the WSIQ2's remote reset input (terminals C41, C42) is normally open or normally closed.

6N – Analog Input Trip

An analog input can be fitted to the WSIQ2 if required. An external device can activate the analog input to trip the soft starter in response to external conditions.

Options: Do Not Trip (default)
Trip High
Trip Low

Description: Selects the soft starter's response to the analog input signal.

6O – Analog Input Scale

Options: 0-10 V (default)
2-10 V

Description: Selects the scale of the analog input.

6P – Analog Trip Point

Range: 0% - 100% **Default:** 50%

Description: Sets the signal level at which an analog input trip will occur, as a percentage of the maximum signal on the input.

6Q – Local/Remote

Options:	LCL/RMT Anytime LCL/RMT When Off Local Control Only Remote Control Only	LCL/RMT button is always enabled. LCL/RMT button is enabled when the starter is off. All remote inputs are disabled. Local control buttons (START , RESET , LCL/RMT) are disabled.
-----------------	--	--

Description: Selects when the **LCL/RMT** button can be used to switch between local and remote control, and enables or disables the local control buttons and remote control inputs.
The **STOP** button on the keypad is always enabled.

**WARNING**

The **STOP** button on the keypad is always enabled. When using two-wire remote control, the soft starter will restart if the remote start/stop and reset inputs are still active.

6R – Comms in Remote

Options: Disable Control in RMT
Enable Control in RMT (default)

Description: Selects whether the starter will accept Start and Stop commands from the serial communication network when in Remote mode. The Reset and Local/Remote Control commands are always enabled.

7 Outputs

The WSIQ2 has three programmable outputs, which can be used to signal different operating conditions to associated equipment. Three additional outputs are available on the input/output expansion card.

7A – Relay A Function

Options:	Off	Relay A is not used.
	Main Contactor (default)	The relay closes when the WSIQ2 receives a start command, and remains closed as long as the motor is receiving voltage.
	Run	The relay closes when the starter changes to run state.
	Trip	The relay closes when the starter trips (refer to parameter 16A to 16X).
	Warning	The relay closes when the starter issues a warning (refer to parameter 16A to 16X).
	Low Current Flag	The relay closes when the low current flag activates while the motor is running (refer to parameter 7M <i>Low Current Flag</i>).
	High Current Flag	The relay closes when the high current flag activates while the motor is running (refer to parameter 7N <i>High Current Flag</i>).
	Motor Temperature Flag	The relay closes when the motor temperature flag activates (refer to parameter 7O <i>Motor Temperature Flag</i>).
	Input A trip	The relay closes when Input A activates to trip the soft starter.
	Input B trip	The relay closes when Input B activates to trip the soft starter.
	Motor overload	The relay closes when the starter trips on Motor Overload.
	Current imbalance	The relay closes when the starter trips on Current Imbalance.
	Undercurrent	The relay closes when the starter trips on Undercurrent.
	Instantaneous overcurrent	The relay closes when the starter trips on Instantaneous overcurrent.
	Frequency	The relay closes when the starter trips on Frequency.
	Ground fault	The relay closes when the starter trips on Ground Fault.
	Heatsink overtemperature	The relay closes when the starter trips on Heatsink Overtemperature.
	Phase Loss	The relay closes when the starter trips on Phase Loss.
	Motor thermistor	The relay closes when the starter trips on Motor Thermistor.
	Changeover Contactor	The relay closes when the high rotor resistance current ramp has reached full voltage, allowing use with a slip-ring motor.
	Undervoltage	Not available with WSIQ2.
	Ready	The relay is closed when the starter is in Ready state.

Description: Selects the function of Relay A (normally open).

7B – Relay A On Delay

Range:	0:00 - 5:00 (minutes:seconds)	Default: 0 second
Description:	Sets the delay for closing Relay A.	

7C – Relay A Off Delay

Range:	0:00 - 5:00 (minutes:seconds)	Default: 0 second
Description:	Sets the delay for re-opening Relay A.	

7D~7L – Output Relays B, C, D, E, F

Parameters 7D~7L configure the operation of Relays B, C, D, E and F in the same way as parameters 7A~7C configure Relay A. Refer to *Relay A Function* for details.

Relay B is a changeover relay.

- 7D *Relay B Function* **Default:** Run
- 7E *Relay B On Delay*
- 7F *Relay B Off Delay*

Relay C is a changeover relay.

- 7G *Relay C Function* **Default:** Trip
- 7H *Relay C On Delay*
- 7I *Relay C Off Delay*

Relays D, E and F are only available if the input/output expansion card has been installed. These relays do not support on or off delays and do not support 'Changeover Contactor' function. Relay D is normally closed, relays E and F are normally open.

- 7J *Relay D Function* **Default:** Off
- 7K *Relay E Function* **Default:** Off
- 7L *Relay F Function* **Default:** Off

7M – Low Current Flag

The WSIQ2 has low and high current flags to give early warning of abnormal operation. The current flags can be configured to indicate an abnormal current level during operation, between the normal operating level and the undercurrent or instantaneous overcurrent trip levels. The flags can signal the situation to external equipment via one of the programmable outputs.

The flags clear when the current returns within the normal operating range by 10% of the programmed flag value.

- Range:** 1% - 100% FLC **Default:** 50%
- Description:** Sets the level at which the low current flag operates, as a percentage of motor full load current.

7N – High Current Flag

- Range:** 50% - 600% FLC **Default:** 100%
- Description:** Sets the level at which the high current flag operates, as a percentage of motor full load current.

7O – Motor Temperature Flag

The WSIQ2 has a motor temperature flag to give early warning of abnormal operation. The flag can indicate that the motor is operating above its normal operating temperature but lower than the overload limit. The flag can signal the situation to external equipment via one of the programmable outputs.

- Range:** 0% - 160% **Default:** 80%
- Description:** Sets the level at which the motor temperature flag operates, as a percentage of the motor's thermal capacity.

7P – Analog Output A

- Options:** Current (% FLC) (default) Current as a percentage of motor full load current.
- Motor Temp (%) Motor temperature as a percentage of the motor's thermal capacity.
- Motor kW (%) Measured motor kilowatts, as a percentage of maximum kW.
- Motor kVA (%) Measured motor kilovolt amperes, as a percentage of maximum kVA.
- Motor pf Motor power factor, measured by the soft starter.

Measured motor kW:	$\sqrt{3} \times \text{average current} \times \text{mains reference voltage} \times \text{measured power factor}$
Maximum motor kW:	$\sqrt{3} \times \text{motor FLC} \times \text{mains reference voltage}$. Power factor is assumed to be 1
Measured motor kVA:	$\sqrt{3} \times \text{average current} \times \text{mains reference voltage}$
Maximum motor kVA:	$\sqrt{3} \times \text{motor FLC} \times \text{mains reference voltage}$

- Description:** Selects which information will be reported via the analog output.

7Q – Analog A Scale

Range: 0-20 mA
4-20 mA (default)
Description: Selects the range of the analog output.

7R – Analog A Maximum

Range: 0% - 600% **Default:** 100%
Description: Calibrates the upper limit of the analog output to match the signal measured on an external current measuring device.

7S – Analog A Minimum

Range: 0% - 600% **Default:** 0%
Description: Calibrates the lower limit of the analog output to match the signal measured on an external current measuring device.

7T, 7U, 7V, 7W – Analog Output B

Parameters 7T~7W configure the operation of *Analog Output B*, in the same way as parameters 7P~7S configure analog output A. Refer to *Analog Output A* for details.
Output B is only available if the input/output expansion card has been installed.

8 Display

These parameters allow the keypad to be tailored to individual users' requirements.

8A – Language

Options: English (default) Portuguese
Chinese Français
Español Italiano
Deutsch Russian
Description: Selects which language the keypad will use to display messages and feedback.

8B, 8C – F1 and F2 Button Action

Options: None
Auto-Start/Stop Menu
Jog Forward
Jog Reverse
Description: Selects the function of the **F1** and **F2** buttons on the keypad.



NOTE

The access code is not required to use the F1 and F2 buttons. Users can access these functions regardless of the setting of parameter 15B *Adjustment Lock*.

8D – Display A or kW

Options: Current (default)
Motor kW
Description: Selects whether the WSIQ2 will display current (amperes) or motor kilowatts on the main monitoring screen.

8E, 8F, 8G, 8H – User-Programmable Screen

Options:	Blank	Displays no data in the selected area, allowing long messages to be shown without overlapping.
	Starter State (default)	The starter's operating state (starting, running, stopping or tripped). Only available for top left and bottom left positions on the screen.
	Motor Current	The average current measured on three phases.
	Motor pf	The motor's power factor, measured by the soft starter.
	Mains Frequency	The average frequency measured on three phases.
	Motor kW	The motor's running power in kilowatts.
	Motor HP	The motor's running power in horsepower.
	Motor Temp	The motor's temperature, calculated by the thermal model.
	kWh	The number of kilowatt hours the motor has run via the soft starter.

Hours Run	The number of hours the motor has run via the soft starter.
Analog Input	The level of analog input A (refer to parameters 6N~6P). This setting is only available if the input/output expansion option is installed.

Description: Selects which information will be displayed on the programmable monitoring screen.

- | | |
|---------------------------------|-------------------------------|
| • 8E User Screen - Top Left | Default: Starter State |
| • 8F User Screen - Top Right | Default: Blank |
| • 8G User Screen - Bottom Left | Default: Hours Run |
| • 8H User Screen - Bottom Right | Default: Analog Input |

8I – Graph Data

The WSIQ2 has a real-time performance graph to report the behaviour of critical operating parameters.

Options:	Current (% FLC) (default)	Current as a percentage of motor full load current.
	Motor Temp (%)	Motor temperature as a percentage of the motor's thermal capacity.
	Motor kW (%)	Measured motor kilowatts, as a percentage of maximum kW.
	Motor kVA (%)	Measured motor kilovolt amperes, as a percentage of maximum kVA.
	Motor pf	Motor power factor, measured by the soft starter.

Measured motor kW:	$\sqrt{3} \times \text{average current} \times \text{mains reference voltage} \times \text{measured power factor}$
Maximum motor kW:	$\sqrt{3} \times \text{motor FLC} \times \text{mains reference voltage}$. Power factor is assumed to be 1
Measured motor kVA:	$\sqrt{3} \times \text{average current} \times \text{mains reference voltage}$
Maximum motor kVA:	$\sqrt{3} \times \text{motor FLC} \times \text{mains reference voltage}$

Description: Selects which information the graph will display.

8J – Graph Timebase

Options:	10 seconds (default)	10 minutes
	30 seconds	30 minutes
	1 minute	1 hour
	5 minutes	

Description: Sets the graph time scale. The graph will progressively replace the old data with new data.

8K – Graph Maximum

Range: 0% – 600% **Default:** 400%

Description: Adjusts the upper limit of the performance graph.

8L – Graph Minimum

Range: 0% – 600% **Default:** 0%

Description: Adjusts the lower limit of the performance graph.

8M – Current Calibration

Range: 85% - 115% **Default:** 100%

Description: Calibrates the soft starter's current monitoring circuits to match an external current metering device.

Use the following formula to determine the necessary adjustment:

$$\text{Calibration (\%)} = \frac{\text{Current shown on WSIQ2 display}}{\text{Current measured by external device}}$$

eg 102% = $\frac{66\text{A}}{65\text{A}}$



NOTE

This adjustment affects all current-based functions and protections.

8N – Mains Reference Voltage**Range:** 100 – 690 V**Default:** 400 V**Description:** Sets the nominal mains voltage for the keypad's monitoring functions. This is used to calculate motor kilowatts and kilovolt amperes (kVA) but does not affect the WSIQ2's motor control or protection.**8O Reserved****Description:** This parameter is reserved for future use.**9 Motor Data-2**

The WSIQ2 can support two different starting and stopping motor data sets.

- To use the WSIQ2 with two separate motors (such as a duty-standby configuration), use parameter 9A to select dual thermal modelling and configure parameters 9B~9E to suit the second motor.
- To use the WSIQ2 with two different motor data sets for the same motor (for dual speed motors or applications where starting conditions may vary), use parameter 9A to select a single thermal model, and configure the starting and stopping profiles as required in parameters 10A~10G. The soft starter will ignore parameters 9B~9E and will use settings from the primary motor.

To select the secondary motor data set, a programmable input must be configured to parameter set selection (parameters 6A and 6F) and the input must be active when the soft starter receives a start signal.

**NOTE**

You can only choose which motor data set to use while the soft starter is stopped.

9A – Dual Thermal Model**Options:** Single (default)
Dual**Description:** Activates dual thermal modelling. The dual thermal model is required only if the WSIQ2 is controlling two physically separate motors.**9B – Motor FLC-2****Range:** Model dependent**Description:** Sets the secondary motor's full load current.**9C – Locked Rotor Time-2****Range:** 0:01 - 2:00 (minutes:seconds)**Default:** 10 seconds**Description:** Sets the maximum length of time the motor can sustain locked rotor current from cold before reaching its maximum temperature. Set according to the motor datasheet.**9D – Locked Rotor Current-2****Range:** 400% - 1200% FLC**Default:** 600%**Description:** Sets the locked rotor current of the connected motor, as a percentage of full load current. Set according to the motor datasheet.**9E – Motor Service Factor-2****Range:** 100% - 130% FLC**Default:** 105%**Description:** Sets the secondary motor's service factor.**10 Start/Stop-2****10A – Start Mode-2****Options:** Constant Current (default)
Adaptive Control**Description:** Selects the soft start mode.**10B – Start Ramp Time-2****Range:** 1 - 180 (seconds)**Default:** 10 seconds**Description:** Sets the total start time for an Adaptive Control start or the ramp time for current ramp starting (from the initial current to the current limit).

10C – Initial Current-2

Range:	100% - 600%	Default:	350%
Description:	Sets the initial start current level for current ramp starting, as a percentage of motor full load current. Set so that the motor begins to accelerate immediately after a start is initiated. If current ramp starting is not required, set the initial current equal to the current limit.		

10D – Current Limit-2

Range:	100% - 600% FLC	Default:	350%
Description:	Sets the current limit for constant current and current ramp soft starting, as a percentage of motor full load current.		

10E – Adaptive Start Profile-2

Options:	Early Acceleration Constant Acceleration (default) Late Acceleration		
Description:	Selects which profile the WSIQ2 will use for an Adaptive Control soft start.		

10F – Kickstart Time-2

Range:	0 - 2000 (milliseconds)	Default:	0000 milliseconds
Description:	Sets the kickstart duration. A setting of 0 disables kickstart.		

10G – Kickstart Level-2

Range:	100% - 700% FLC	Default:	500%
Description:	Sets the level of the kickstart current.		

10H – Stop Mode-2

Options:	Coast To Stop (default) TVR Soft Stop Adaptive Control Brake		
Description:	Selects the stop mode.		

10I – Stop Time-2

Range:	0:00 - 4:00 (minutes:seconds)	Default:	0 second
Description:	Sets the stop time.		

10J – Adaptive Stop Profile-2

Options:	Early Deceleration Constant Deceleration (default) Late Deceleration		
Description:	Selects which profile the WSIQ2 will use for an Adaptive Control soft stop.		

10K – Adaptive Control Gain-2

Range:	1% - 200%	Default:	75%
Description:	Adjusts the performance of Adaptive Control. This setting affects both starting and stopping control.		

10L – Brake Torque-2

Range:	20% - 100%	Default:	20%
Description:	Sets the amount of brake torque the WSIQ2 will use to slow the motor.		

10M – Brake Time-2

Range:	1 - 30 (seconds)	Default:	1 second
Description:	Sets the duration for DC injection during a braking stop.		

11 RTD Temperatures

The WSIQ2 has one RTD/PT100 input and can be fitted with another six PT100 inputs by using the RTD/PT100 and ground fault protection card. The inputs can trip the soft starter when the temperature exceeds a specified point, and different trip temperatures can be set for each input.

PT100 inputs B ~ G are only available if the RTD/PT100 and ground fault protection card has been installed.

Range: 0 - 250 ° C **Default:** 50 ° C

Description: Sets the trip points for the RTD/PT100 inputs.

- 11A RTD A Trip Temp
- 11B RTD B Trip Temp
- 11C RTD C Trip Temp
- 11D RTD D Trip Temp
- 11E RTD E Trip Temp
- 11F RTD F Trip Temp
- 11G RTD G Trip Temp

12 Slip-Ring Motors

These parameters allow the soft starter to be configured for use with a slip-ring motor.

12A, 12B – Motor Data-1 and Motor Data-2 Ramp

Options: Single Ramp (default)
Dual Ramp

Description: Selects whether to use a single or dual current ramp profile for soft starting. Set to single ramp for non-slip ring induction motors, or dual ramp for slip-ring induction motors.
Parameter 12A selects the ramp configuration for the primary motor and parameter 12B selects the ramp configuration for the secondary motor.

12C – Changeover Time

Range: 100 - 500 (milliseconds) **Default:** 150 milliseconds

Description: Sets the delay between the rotor resistance relay closing and the low resistance current ramp starting. Set so that the contactor has enough time to close, but the motor does not slow down.
Parameter 12C only applies if parameter 12A or 12B is set to 'Dual Ramp', and an output relay is set to 'Changeover Contactor'.

12D – Slip-Ring Retard

Range: 10% - 90% **Default:** 50%

Description: Sets the level of conduction after the rotor resistance contactor closes, as a percentage of full conduction.
Set so that no current pulse occurs, but the motor retains enough speed to start correctly.

15 Advanced

15A – Access Code

Range: 0000 - 9999

Default: 0000

Description: Sets the access code to control access to restricted sections of the menus. Use the ◀ and ▶ buttons to select which digit to alter and use the ▲ and ▼ buttons to change the value.



NOTE

In the event of a lost access code, contact your supplier for a master access code that allows you to re-program a new access code.

15B – Adjustment Lock

Options: Read & Write (default) Allows users to alter parameter values in the Programming Menu.
Read Only Prevents users altering parameter values in the Programming Menu. Parameter values can still be viewed.

Description: Selects whether the keypad will allow parameters to be changed via the Programming Menu.



NOTE

Changes to the Adjustment Lock setting take effect only after the Programming Menu has been closed.

15C – Emergency Run

Options: Disable (default)
Enable

Description: Selects whether the soft starter will permit emergency run operation. In emergency run, the soft starter will start (if not already running) and continue to operate until emergency run ends, ignoring stop commands and trips. Emergency run is controlled using a programmable input.



CAUTION

Continued use of Emergency Run is not recommended. Emergency Run may compromise the starter life as all protections and trips are disabled.

Using the starter in 'Emergency Run' mode will void the product warranty.

15D – Shorted SCR Action

Options: 3-Phase Control Only (default)
PowerThrough

Description: Selects whether the soft starter will allow PowerThrough operation, if the soft starter is damaged on one phase. The soft starter will use two-phase control, allowing the motor to continue operating in critical applications.

- PowerThrough is only available with in-line installations. If the starter is installed inside delta, PowerThrough will not operate.
- PowerThrough remains active until '3-Phase Control Only' is reselected.

A shorted SCR will trip the starter on 'Lx-Tx shorted'. If PowerThrough is enabled, the trip can be reset and subsequent starts will use PowerThrough two-phase control; however not all features will be available. The trip LED will flash and the display will indicate '2 Phase - Damaged SCR'.



CAUTION

PowerThrough uses a two-phase soft start technology and additional care is required when sizing circuit breakers and protection. Contact your local supplier for assistance.



CAUTION

The starter will trip on Lx-Tx Shorted on the first start attempt after control power is applied. PowerThrough will not operate if control power is cycled between starts.

PowerThrough operation does not support Adaptive Control soft starting or soft stopping. In PowerThrough, the WSIQ2 will automatically select constant current soft starting and timed voltage ramp soft stopping. If PowerThrough is enabled, parameters 2C and 2D must be set appropriately.

15E – Jog Torque

The WSIQ2 can jog the motor at a reduced speed, which allows precise positioning of belts and flywheels. Jog can be used for either forward or reverse operation.

Range: 20% - 100% **Default:** 50%

Description: Sets the current limit for jog operation.

16 Protection Action

These parameters define how the soft starter will respond to different protection events. The soft starter can trip, issue a warning, or ignore different protection events as required. All protection events are written to the event log. The default action for all protections is to trip the soft starter.

Protections 16N *Ground Fault* and 16P~16U *RTD/PT100* are only available if the RTD/PT100 and ground fault protection card has been fitted.



CAUTION

Defeating the protection may compromise the starter and motor, and should only be done in the case of emergency.

16A~16X – Protection Actions

Options: Trip Starter (default)
Warn and Log
Log Only

Description: Selects the soft starter's response to each protection.

- 16A *Motor Overload*
- 16B *Excess Start Time*
- 16C *Undercurrent*
- 16D *Instantaneous Overcurrent*
- 16E *Current Imbalance*
- 16F *Frequency*
- 16G *Input A Trip*
- 16H *Input B Trip*
- 16I *Motor Thermistor*
- 16J *Starter Communication*
- 16K *Network Communication*
- 16L *Heatsink Overtemperature*
- 16M *Battery/Clock*
- 16N *Ground Fault*
- 16O~16U *RTD A~G Overtemperature*
- 16V *Reserved*
- 16W *Reserved*
- 16X *Low Control Volts*

20 Restricted

These parameters are restricted for Factory use and are not available to the user.

12 Application Examples

12.1 Installation with Main Contactor

The WSIQ2 is installed with a main contactor (AC3 rated). Control voltage must be supplied from the input side of the contactor.

The main contactor is controlled by the WSIQ2 Main Contactor output, which by default is assigned to Output Relay A (terminals 13, 14).

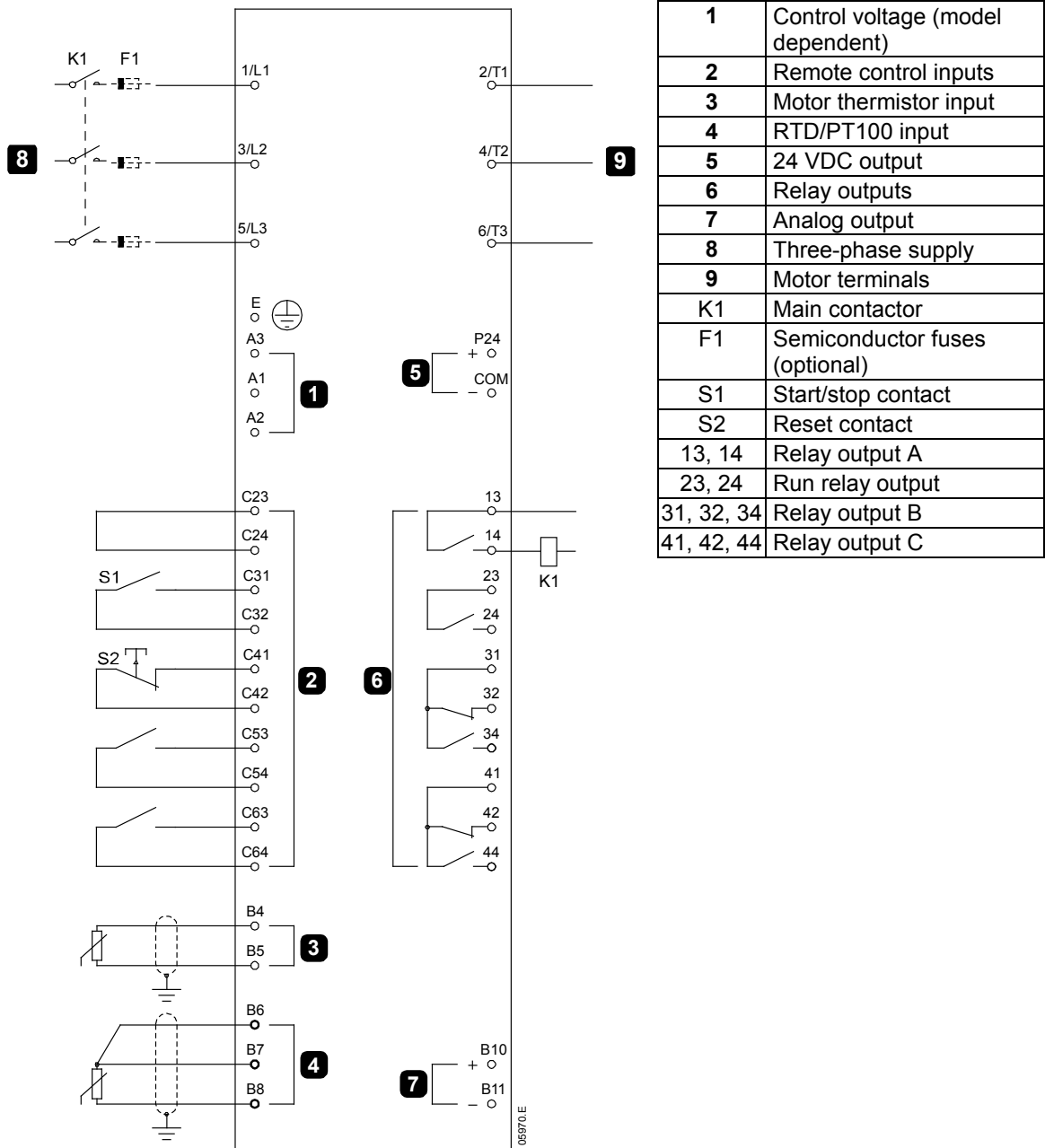

Parameter settings:

- Parameter 7A *Relay A Function*
 - Select 'Main Contactor' - assigns the Main Contactor function to Relay Output A (default setting)

12.2 Installation with External Bypass Contactor

The WSIQ2 is installed with an external bypass contactor (AC1 rated). The bypass contactor is controlled by the WSIQ2 Run Output (terminals 23, 24).

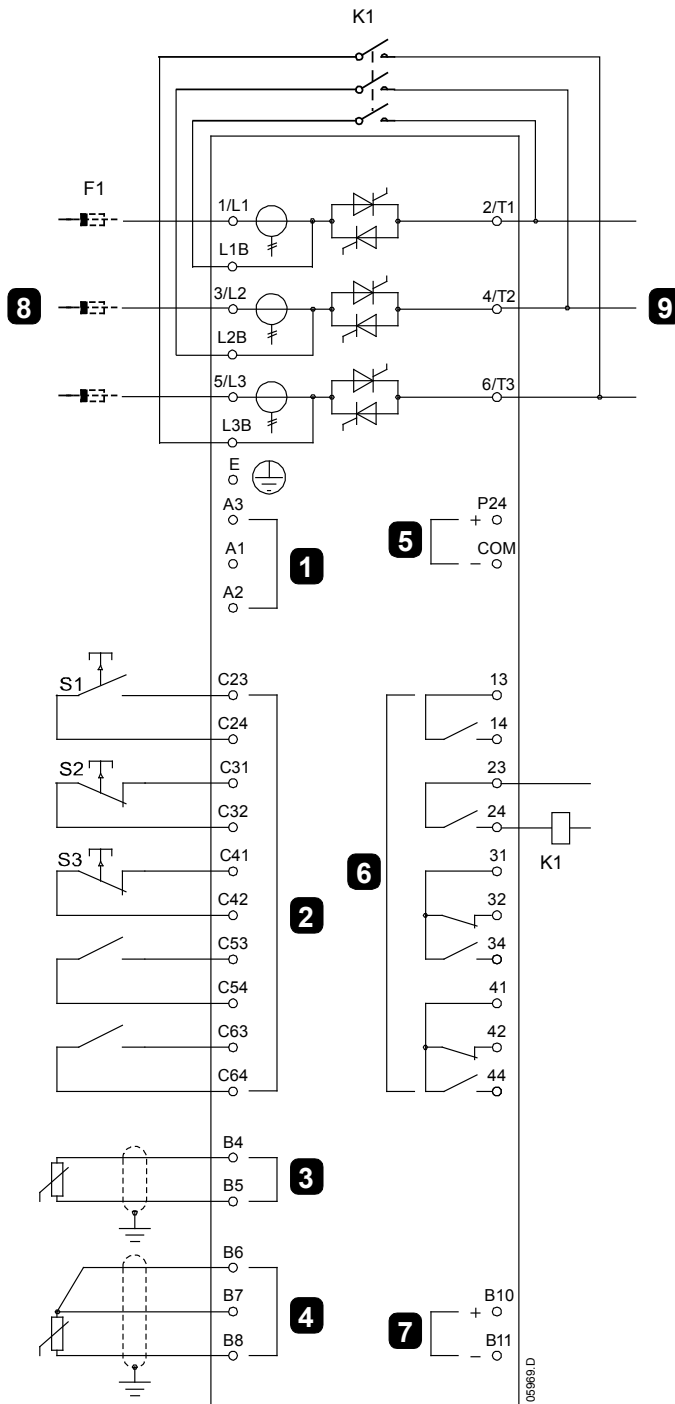

1	Control voltage (model dependent)
2	Remote control inputs
3	Motor thermistor input
4	RTD/PT100 input
5	24 VDC output
6	Relay outputs
7	Analogue output
8	Three-phase supply
9	Motor terminals
K1	Bypass contactor (external)
F1	Semiconductor fuses (optional)
S1	Start contact
S2	Stop contact
S3	Reset contact
13, 14	Relay output A
23, 24	Run relay output
31, 32, 34	Relay output B
41, 42, 44	Relay output C

Parameter settings:

- No special settings required.

12.3 Emergency Run Operation

In normal operation the WSIQ2 is controlled via a remote two-wire signal (terminals C31, C32).

Emergency Run is controlled by a two-wire circuit connected to Input A (terminals C53, C54). Closing Input A causes the WSIQ2 to run the motor and ignore certain trip conditions.



NOTE

Although the Emergency Run satisfies the functionality requirements of Fire Mode, WorldWide Electric does not recommend its use in situations that require testing and/or compliance with specific standards as it is not certified.



CAUTION

Continued use of Emergency Run is not recommended. Emergency Run may compromise the starter life as all protections and trips are disabled.

Using the starter in 'Emergency Run' mode will void the product warranty.

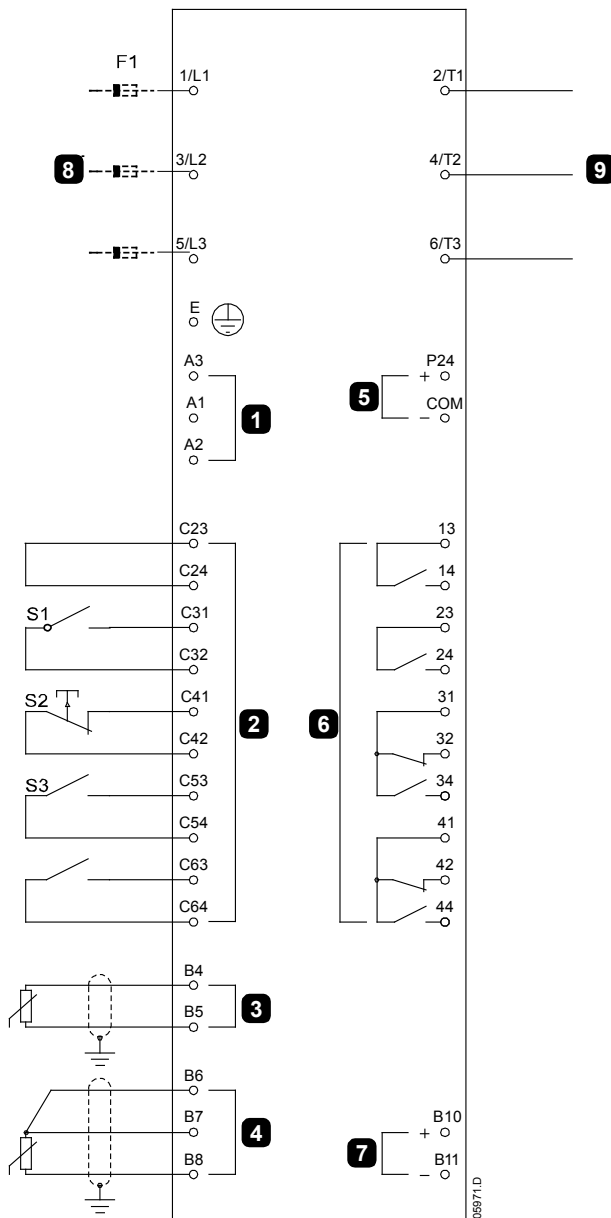

1	Control voltage (model dependent)
2	Remote control inputs
3	Motor thermistor input
4	RTD/PT100 input
5	24 VDC output
6	Relay outputs
7	Analog output
8	Three-phase supply
9	Motor terminals
S1	Start/stop contact
S2	Reset contact
S3	Emergency Run Contact
F1	Semiconductor fuses (optional)
13, 14	Relay output A
23, 24	Run relay output
31, 32, 34	Relay output B
41, 42, 44	Relay output C

Parameter settings:

- Parameter 6A *Input A Function*
 - Select 'Emergency Run' - assigns Input A for Emergency Run function.
- Parameter 15C *Emergency Run*
 - Select 'Enable' - Enables Emergency Run mode.

12.4 Auxiliary Trip Circuit

In normal operation the WSIQ2 is controlled via a remote two-wire signal (terminals C31, C32).

Input A (terminals C53, C54) is connected to an external trip circuit (such as a low pressure alarm switch for a pumping system). When the external circuit activates, the soft starter trips, which stops the motor.

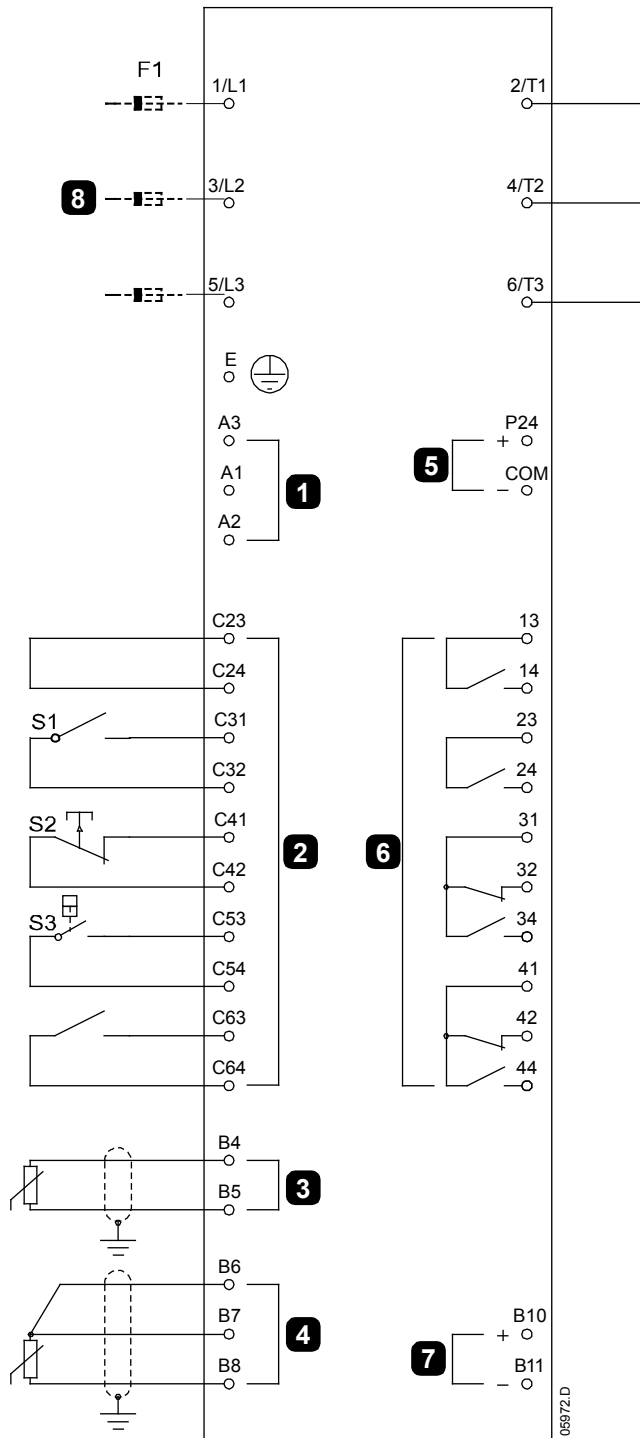

1	Control voltage (model dependent)
2	Remote control inputs
3	Motor thermistor input
4	RTD/PT100 input
5	24 VDC output
6	Relay outputs
7	Analog output
8	Three-phase supply
9	Motor terminals
S1	Start/stop contact
S2	Reset contact
S3	Auxiliary trip contact
F1	Semiconductor fuses (optional)
13, 14	Relay output A
23, 24	Run relay output
31, 32, 34	Relay output B
41, 42, 44	Relay output C

Parameter settings:

- **Parameter 6A Input A Function**
 - Select 'Input Trip (N/O)'. Assigns the Input A to Auxiliary Trip (N/O) function.
- **Parameter 6B Input A Name**
 - Select a name, eg Low Pressure. Assigns a name to Input A.
- **Parameter 6C Input A Trip**
 - Set as required. For example, 'Run Only' limits the input trip to when the soft starter is running only.

- Parameter 6D *Input A Trip Delay*
 - Set as required. Sets a delay between the input activating and the soft starter tripping.
- Parameter 6E *Input A Initial Delay*
 - Set at around 120 seconds. Limits operation of the input trip to 120 seconds after the start signal. This allows time for pressure to build up in the piping before the low pressure input becomes active.

12.5 DC Brake with External Zero Speed Sensor

For loads which may vary between braking cycles, there are benefits in using an external zero-speed sensor to interface with the WSIQ2 for brake shut-off. This control method ensures that the WSIQ2 braking will always shut off when the motor has reached a standstill, thus avoiding unnecessary motor heating.

The following schematic diagram shows how you can use a zero-speed sensor with the WSIQ2 to turn the brake function off at motor standstill. The zero-speed sensor (A2) is often referred to as an under-speed detector. Its internal contact is open at zero-speed and closed at any speed above zero-speed. Once the motor has reached a standstill, C53, C54 will open and the starter will be disabled. When the next start command is given (ie next application of K10), C53, C54 closes and the WSIQ2 is enabled.

The WSIQ2 must be operated in remote mode and parameter 6A *Input A Function* must be set to 'Starter Disable'.



CAUTION

Brake operation causes the motor to heat faster than the rate calculated by the motor thermal model. If you are using brake, install a motor thermistor or allow sufficient restart delay (parameter 4M).

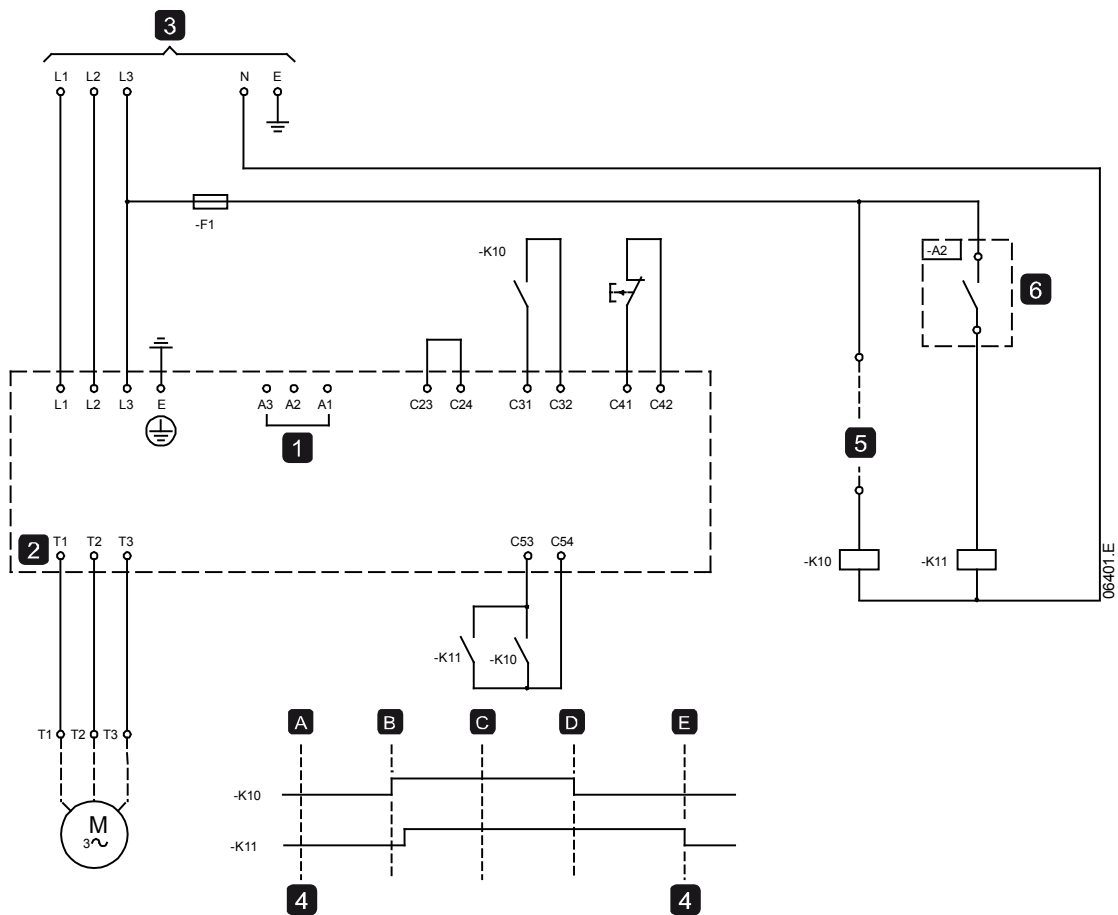

1	Control voltage
C23, C24	Start
C31, C32	Stop
C41, C42	Reset
C53, C54	Programmable input A (Starter Disable)
2	Motor terminals
3	Three-phase supply
4	Starter Disable (shown on starter display)

A	Off (Ready)
B	Start
C	Run
D	Stop
E	Zero speed
5	Start signal
6	Zero speed sensor

For details on configuring DC Brake, refer to Brake on page 31.



CAUTION

When using DC brake, the mains supply must be connected to the soft starter (input terminals L1, L2, L3) in positive phase sequence and parameter 4G *Phase Sequence* must be set to Positive Only.

**CAUTION**

If the brake torque is set too high, the motor will stop before the end of the brake time and the motor will suffer unnecessary heating which could result in damage. Careful configuration is required to ensure safe operation of the starter and motor.

A high brake torque setting can result in peak currents up to motor DOL being drawn while the motor is stopping. Ensure protection fuses installed in the motor branch circuit are selected appropriately.

12.6 Soft Braking

For applications with high inertia and/or a variable load, the WSIQ2 can be configured for soft braking. In this application the WSIQ2 is employed with forward run and braking contactors. When the WSIQ2 receives a start signal (pushbutton S1), it closes the forward run contactor (K1) and controls the motor according to the programmed primary motor settings.

When the WSIQ2 receives a stop signal (pushbutton S2), it opens the forward run contactor (K1) and closes the braking contactor (K2) after a delay of approximately 2-3 seconds (K1T). K12 is also closed to activate the secondary motor settings, which should be user programmed for the desired stopping performance characteristics.

When motor speed approaches zero, the zero speed sensor (A2) stops the soft starter and opens the braking contactor (K2).

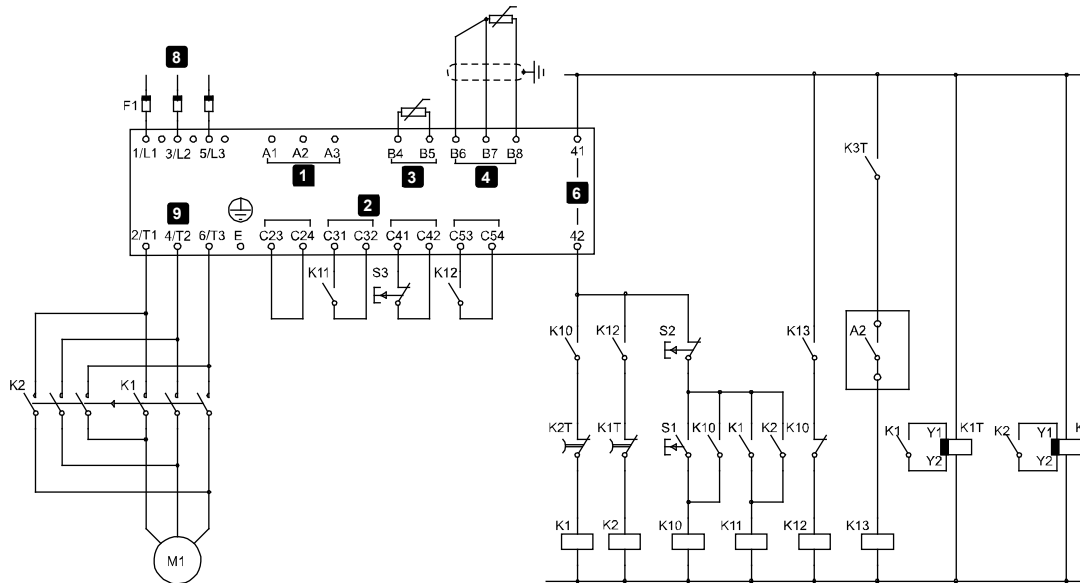

1	Control voltage (model dependent)
2	Remote control inputs
3	Motor thermistor input
4	RTD/PT100 input
5	Relay outputs
6	Three-phase supply
7	Motor terminals
A2	Zero speed sensor
F1	Semiconductor fuses (optional)
K10	Run relay
K11	Start relay

K12	Brake relay
K13	Zero speed sensor relay
K1	Line contactor (Run)
K2	Line contactor (Brake)
K1T	Run delay timer
K2T	Brake delay timer
K3T	Zero speed sensor delay timer*
S1	Start contact
S2	Stop contact
S3	Reset contact

* The K3T timer is only required if the zero speed sensor is the type that performs a self-test upon power-up and momentarily closes the output relay.

Parameter settings:

- Parameter 6A *Input A Function* (terminals C53, C54)
 - Select 'Motor Set Select' - assigns Input A for Motor set selection.
 - Set starting performance characteristics using the primary motor set.
 - Set braking performance characteristics using the secondary motor settings.
- Parameter 7G *Relay C Function*
 - Select 'Trip' - assigns Trip function to Relay Output C.



NOTE

If the WSIQ2 trips on supply frequency (parameter 16F *Frequency*) when the braking contactor K2 opens, modify the frequency protection settings.

12.7 Two-Speed Motor

The WSIQ2 can be configured for control of dual speed Dahlander type motors, using a high speed contactor (K1), low speed contactor (K2) and a star contactor (K3).



NOTE

Pole Amplitude Modulated (PAM) motors alter the speed by effectively changing the stator frequency using external winding configuration. Soft starters are not suitable for use with this type of two-speed motor.

When the soft starter receives a high speed start signal, it closes the high speed contactor (K1) and star contactor (K3), then controls the motor according to the primary motor settings.

When the soft starter receives a low speed start signal, it closes the low speed contactor (K2). This closes Input A and the WSIQ2 controls the motor according to the secondary motor settings.

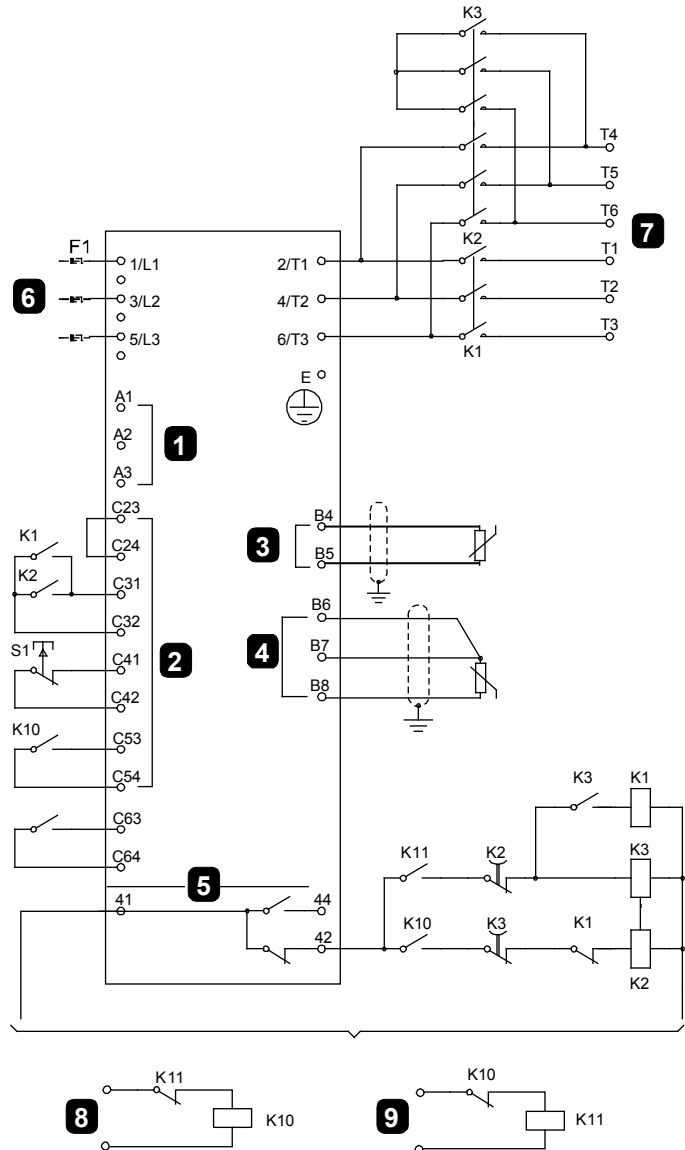

1	Control voltage		F1	Semiconductor fuses (optional)
2	Remote control inputs		K10	Remote start relay (low speed)
3	Motor thermistor input		K11	Remote start relay (high speed)
4	RTD/PT100 input		K1	Line contactor (high speed)
5	Relay outputs		K2	Line contactor (low speed)
6	Three-phase supply		K3	Star contactor (high speed)
7	Motor terminals		S1	Reset contact
8	Remote low speed start input		41, 42, 44	Relay output C
9	Remote high speed start input			

**NOTE**

Contactors K2 and K3 must be mechanically interlocked.

Parameter settings:

- Parameter *6A Input A Function* (terminals C53, C54)
 - Select 'Motor Set Select' - assigns Input A for Motor set selection.
 - Set high speed performance characteristics using the primary motor settings.
 - Set low speed performance characteristics using the secondary motor settings.
- Parameter *7G Relay C Function*
 - Select 'Trip' - assigns Trip function to Relay Output C

**NOTE**

If the WSIQ2 trips on supply frequency (parameter 16F *Frequency*) when the high-speed start signal (9) is removed, modify the frequency protection settings.

12.8 Slip-Ring Motor

The WSIQ2 can be used to control a slip-ring motor, using rotor resistance.

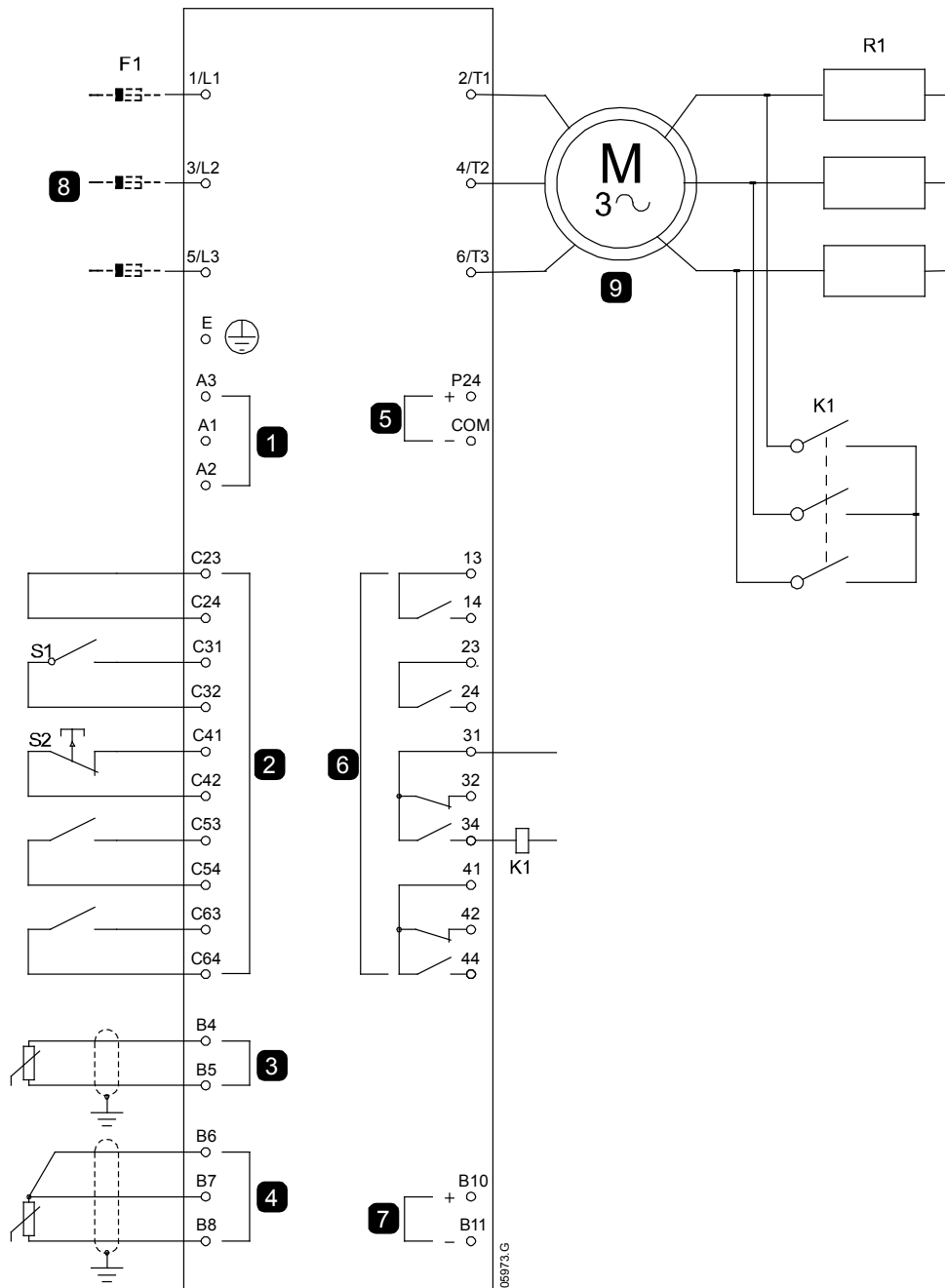

1	Control voltage (model dependent)
2	Remote control inputs
3	Motor thermistor input
4	RTD/PT100 input
5	24 VDC output
6	Relay outputs
7	Analog output
8	Three-phase supply
9	Slip-ring induction motor
K1	Changeover contactor
F1	Semiconductor fuses (optional)
S1	Start/stop contact
S2	Reset contact
R1	Rotor resistance (external)

Commissioning

1. Configure the WSIQ2 as follows:

Parameter settings:

- Parameter 7D *Relay B Function*
 - Select 'Changeover contactor'
 - Parameter 7E *Relay B On Delay*
 - Set this to the maximum time (5m:00s).
 - Parameter 12A *Motor Data-1 Ramp*
 - Select 'Dual Ramp' (for slip-ring induction motor control)
 - Parameter 12C *Changeover Time*
 - Default setting is 150 milliseconds. Set this to a value just greater than the changeover contactor (K1) pole closing time.
 - Parameter 12D *Slip Ring Retard*
 - Default setting is 50%. Set this parameter to a value which is high enough to cause the motor to instantly accelerate once the rotor resistance (R1) has been bridged out and low enough to avoid a motor current pulse.
2. Start the motor under normal load conditions and record the time it takes to reach a constant speed with external rotor resistance (R1) in the circuit. Stop the motor soon after a constant speed has been reached. Change parameter 7E to the recorded time value.
3. Start the motor under normal load conditions and monitor the motor speed behaviour and motor current when the changeover contactor (K1) switches in to short-out the rotor resistance (R1). If the motor does not accelerate immediately after changeover, increase the setting of parameter 12D. If there is a pulse in motor current immediately after changeover, reduce the setting of parameter 12D.

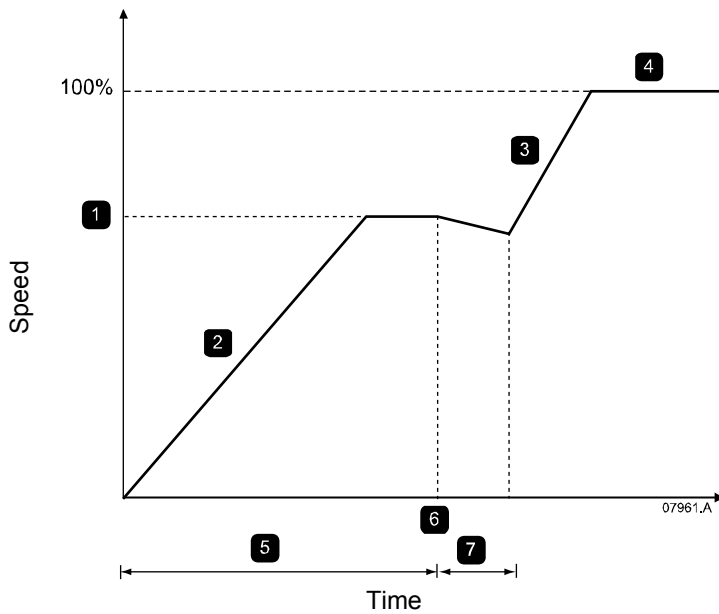

1	R1 Constant Speed
2	First ramp
3	Second ramp
4	Run mode ($I < 120\%$ FLC)

5	Parameter 7E <i>Relay B On Delay</i>
6	K1 closes
7	Parameter 12C <i>Changeover Time</i>



NOTE

For this installation to function correctly, only use the primary motor settings with constant current start method (parameter 2A *Start Mode*).

13 Troubleshooting

13.1 Protection Responses

When a protection condition is detected, the WSIQ2 will write this to the event log and may also trip or issue a warning. The soft starter's response depends on the Protection Action setting (parameter group 16).

Some protection responses cannot be adjusted by the user. These trips are usually caused by external events (such as phase loss) or by a fault within the soft starter. These trips do not have associated parameters and cannot be set to Warn or Log.



If the WSIQ2 trips you will need to identify and clear the condition that triggered the trip, then reset the soft starter before restarting. To reset the starter, press the **RESET** button on the keypad or activate the Reset remote input.



If the WSIQ2 has issued a warning, the soft starter will reset itself once the cause of the warning has been resolved.

13.2 Trip Messages

This table lists soft starter's protection mechanisms and the probable cause of the trip. Some of these can be adjusted using parameter group 4 Protection Settings and parameter group 16 Protection Action, other settings are built-in system protections and cannot be set or adjusted.

Display	Possible cause/Suggested solution
2 Phase - Damaged SCR	This message is displayed if the soft starter tripped on "Lx-Tx shorted" during the pre-start checks and PowerThrough is enabled. It indicates that the starter now operates in PowerThrough mode (2-phase control only). Check for a shorted SCR. Related parameters: 15D
Analog input trip	Identify and resolve the condition which caused Analog Input A to activate. Related parameters: 6N, 6O, 6P
Awaiting data	The keypad is not receiving data from the control PCB. Check the cable connection and the fitting of the display on the starter.
Battery/clock	A verification error has occurred on the real time clock, or the backup battery voltage is low. If the battery is low and the power is off, date/time settings will be lost. The WSIQ2 will continue to soft start and soft stop correctly. Reprogram the date and time. The battery is not removable. In order to replace the battery, the main control PCB must be replaced. Related parameters: 16M
Controller	This is a name selected for a programmable input. Refer to Input A trip.
Current imbalance	Current imbalance can be caused by problems with the motor, the environment or the installation, such as: <ul style="list-style-type: none"> • An imbalance in the incoming mains voltage • A problem with the motor windings • A light load on the motor • A phase loss on input terminals L1, L2 or L3 during Run mode • An SCR that has failed open circuit. A failed SCR can only be definitely diagnosed by replacing the SCR and checking the starter's performance. Related parameters: 4H, 4I, 16E
Current Read Err Lx	Where 'X' is 1, 2 or 3. Internal fault (PCB fault). The output from the CT circuit is not close enough to zero when the SCRs are turned off. Contact your local supplier for advice. This trip is not adjustable. Related parameters: None
Excess start time	Excess start time trip can occur in the following conditions: <ul style="list-style-type: none"> • parameter 1A <i>Motor Full Load Current</i> is not appropriate for the motor • parameter 2D <i>Current Limit</i> has been set too low • parameter 2B <i>Start Ramp Time</i> has been set greater than the setting for 4A <i>Excess Start Time</i> setting • parameter 2B <i>Start Ramp Time</i> is set too short for a high inertia load when using Adaptive Control Related parameters: 1A, 2B, 2D, 4A, 4B, 9B, 10B, 10D, 16B

Display	Possible cause/Suggested solution
Firing Fail Px	Where 'X' is phase 1, 2 or 3. The SCR did not fire as expected. The SCR may be faulty or there may be an internal wiring fault. This trip is not adjustable. Related parameters: None
FLC too high	This trip is not adjustable. The WSIQ2 can support higher motor full load current values when connected to the motor using inside delta configuration rather than in-line connection. If the soft starter is connected in-line but the programmed setting for parameter 1A <i>Motor Full Load Current</i> is above the in-line maximum, the soft starter will trip at start (see Minimum and Maximum Current Settings on page 77). If the soft starter is connected to the motor using inside delta configuration, the soft starter may not be correctly detecting the connection. Contact your local supplier for advice. Related parameters: 1A, 9B
Frequency	This trip is not adjustable. The mains frequency has gone beyond the specified range. Check for other equipment in the area that could be affecting the mains supply, particularly variable speed drives and switch mode power supplies (SMPS). If the WSIQ2 is connected to a generator set supply, the generator may be too small or could have a speed regulation problem. Related parameters: 4J, 4K, 4L, 16F
Ground Fault	Test the insulation of the output cables and the motor. Identify and resolve the cause of any ground fault.  NOTE Ground fault protection is only available if the RTD/PT100 and ground fault protection card is fitted. Related parameters: 4O, 4P, 16N
Heatsink overtemperature	Check if cooling fans are operating. If mounted in an enclosure, check if ventilation is adequate. Fans operate during Start, Run and for 10 minutes after the starter exits the Stop state.  NOTE Cooling fans operate from a Start until 10 minutes after a Stop. Related parameters: None
High Level	This is a name selected for a programmable input. Refer to Input A trip.
High Pressure	This is a name selected for a programmable input. Refer to Input A trip.
Input A trip Input B trip	One of the soft starter's inputs is set to a trip function and has activated. Check the status of the inputs to identify which input has activated, then resolve the trigger condition. Related parameters: 6A, 7B, 7C, 7D, 7E, 7F, 7G, 7H
Instantaneous overcurrent	This trip is not adjustable. The current on all three phases has exceeded 7.2 times the value of parameter 1A <i>Motor Full Load Current</i> . Causes can include a locked rotor condition or an electrical fault in the motor or cabling. Related parameters: None
Internal fault X	This trip is not adjustable. The WSIQ2 has tripped on an internal fault. Contact your local supplier with the fault code (X). Related parameters: None
L1 phase loss L2 phase loss L3 phase loss	This trip is not adjustable. During pre-start checks the starter has detected a phase loss as indicated. In run state, the starter has detected that the current on the affected phase has dropped below 2% of the programmed motor FLC for more than 1 second, indicating that either the incoming phase or connection to the motor has been lost. Check the supply and the input and output connections at the starter and at the motor end. Related parameters: None

Display	Possible cause/Suggested solution
L1-T1 shorted L2-T2 shorted L3-T3 shorted	During pre-start checks the starter has detected a shorted SCR as indicated. Consider using PowerThrough to allow operation until the starter can be repaired. Related parameters: 15D
Low Control Volts	The WSIQ2 has detected a drop in the internal control voltage. <ul style="list-style-type: none"> Check the external control supply (A1, A2, A3) and reset the starter. If the external control supply is stable, the 24 V supply on the main control PCB may be faulty. Contact your local supplier for advice. This protection is not active in Ready state. Related parameters: 16X
Low Level	This is a name selected for a programmable input. Refer to Input A trip.
Low Pressure	This is a name selected for a programmable input. Refer to Input A trip.
Motor Connection Tx	Where 'X' is 1, 2 or 3. The motor is not connected correctly to the soft starter. <ul style="list-style-type: none"> Check individual motor connections to the soft starter for power circuit continuity. Check connections at the motor terminal box. This trip is not adjustable. Related parameters: None
Motor overload Motor 2 overload	The motor has reached its maximum thermal capacity. Overload can be caused by: <ul style="list-style-type: none"> The soft starter protection settings not matching the motor thermal capacity Excessive starts per hour or start duration Excessive current Damage to the motor windings Resolve the cause of the overload and allow the motor to cool. Related parameters: 1A, 1B, 1C, 1D, 16A  NOTE Parameters 1B, 1C and 1D determine the trip current for motor overload protection. The default settings of parameters 1B, 1C and 1D provide Motor Overload Protection: Class 10, Trip Current 105% of FLA (full load amperage) or equivalent.
Motor thermistor	The motor thermistor input has been enabled and: <ul style="list-style-type: none"> The resistance at the thermistor input has exceeded 3.6 kΩ for more than one second. The motor winding has overheated. Identify the cause of the overheating and allow the motor to cool before restarting. The motor thermistor input has been opened.  NOTE If a valid motor thermistor is no longer used, a 1.2 kΩ resistor must be fitted across terminals B4, B5. Related parameters: 16l
Network communication	There is a network communication problem, or the network master may have sent a trip command to the starter. Check the network for causes of communication inactivity. Related parameters: 16K
No Flow	This is a name selected for a programmable input. Refer to Input A trip.
Not ready	Check Input A (C53, C54). The starter may be disabled via a programmable input. If parameter 6A or 6F is set to Starter Disable and there is an open circuit on the corresponding input, the WSIQ2 will not start.

Display	Possible cause/Suggested solution
Parameter out of range	<p>This trip is not adjustable.</p> <ul style="list-style-type: none"> A parameter value is outside the valid range. The keypad will indicate the first invalid parameter. An error occurred loading data from the EEPROM to RAM when the keypad powered up. The parameter set or values in the keypad do not match the parameters in the starter. "Load User Set" has been selected but no saved file is available. <p>Reset the fault. The starter will load the default settings. If the problem persists, contact your local distributor. Related parameters: None Related parameters: None</p>
Phase sequence	<p>The phase sequence on the soft starter's input terminals (L1, L2, L3) is not valid. Check the phase sequence on L1, L2, L3 and ensure the setting in parameter 4G is suitable for the installation. Related parameters: 4G</p>
PLC	<p>This is a name selected for a programmable input. Refer to Input A trip.</p>
Power loss	<p>This trip is not adjustable. The starter is not receiving mains supply on one or more phases when a Start Command is given. Check that the main contactor closes when a start command is given, and remains closed until the end of a soft stop. Check the fuses. If testing the soft starter with a small motor, it must draw at least 2% of its minimum FLC setting on each phase. Related parameters: None</p>
Pump Fault	<p>This is a name selected for a programmable input. Refer to Input A trip.</p>
RTD/PT100 A~ RTD/PT100 G	<p>The RTD/PT100 set temperature has been exceeded and tripped the soft starter. Identify and resolve the condition which caused the appropriate input to activate.</p> <p> NOTE PT100 B to PT100 G are applicable only if a RTD/PT100 and Ground Fault card is fitted.</p> <p>Related parameters: 11A, 11B, 11C, 11D, 11E, 11F, 11G, 16O ~ 16U</p>
RTD circuit fail	<p>Indicates that the indicated RTD/PT100 has short circuited. Check and resolve this condition. Related parameters: None</p>
Starter communication	<ul style="list-style-type: none"> There is a problem with the connection between the soft starter and the optional communications module. Remove and reinstall the module. If the problem persists, contact your local distributor. There is an internal communications error within the soft starter. Contact your local distributor. <p>Related parameters: 16J</p>
Starter Disable	<p>This is a name selected for a programmable input. Refer to Input A trip.</p>
Thermistor circuit	<p>The thermistor input has been enabled and:</p> <ul style="list-style-type: none"> The resistance at the input has fallen below 20 Ω (the cold resistance of most thermistors will be over this value) or A short circuit has occurred. Check and resolve this condition. <p>Related parameters: None</p>
Undercurrent	<p>The motor has experienced a sharp drop in current, caused by loss of load. Causes can include broken components (shafts, belts or couplings), or a pump running dry. Related parameters: 4C, 4D, 16C</p>
Unsupported option	<p>This trip is not adjustable. The selected function is not available (eg jog is not supported in inside delta configuration). Related parameters: None</p>
Vibration	<p>This is a name selected for a programmable input. Refer to Input A trip.</p>
VZC Fail P _x	<p>Where 'X' is 1, 2 or 3. Internal fault (PCB fault). Contact your local supplier for advice. This trip is not adjustable. Related parameters: None</p>

13.3 General Faults

This table describes situations where the soft starter does not operate as expected but does not trip or give a warning.

Symptom	Probable Cause
Starter "Not Ready"	<ul style="list-style-type: none"> Check Input A (C53, C54). The starter may be disabled via a programmable input. If parameter 6A or 6F is set to Starter Disable and there is an open circuit on the corresponding input, the WSIQ2 will not start.
The soft starter does not respond to the START or RESET button on the keypad.	<ul style="list-style-type: none"> The soft starter may be in Remote control mode. When the soft starter is in Remote control mode, the Local LED on the starter is off. Press the LCL/RMT button once to change to Local control.
The soft starter does not respond to commands from the control inputs.	<ul style="list-style-type: none"> The soft starter may be in Local control mode. When the soft starter is in Local control mode, the Local LED on the starter is on. Press the LCL/RMT button once to change to Remote control. The control wiring may be incorrect. Check that the remote start, stop and reset inputs are configured correctly (refer to <i>Control Wiring</i> on page 10 for details). The signals to the remote inputs may be incorrect. Test the signalling by activating each input signal in turn. The appropriate remote control input LED should activate on the starter.
The soft starter does not respond to a start command from either the local or remote controls.	<ul style="list-style-type: none"> The soft starter may be waiting for the restart delay to elapse. The length of the restart delay is controlled by parameter 4M <i>Restart Delay</i>. The motor may be too hot to permit a start. If parameter 4N <i>Motor Temperature Check</i> is set to Check, the soft starter will only permit a start when it calculates that the motor has sufficient thermal capacity to complete the start successfully. Wait for the motor to cool before attempting another start. The starter may be disabled via a programmable input. If parameter 6A or 6F is set to Starter Disable and there is an open circuit on the corresponding input, the WSIQ2 will not start. If there is no further need to disable the starter, close the circuit on the input. <p>NOTE</p>  <p>Parameter 6Q <i>Local/Remote</i> controls when the LCL/RMT button is enabled.</p>
A reset does not occur after an Auto-Reset, when using a remote two-wire control.	<ul style="list-style-type: none"> The remote 2-wire start signal must be removed and reapplied for a re-start.
Remote start/stop command is overriding Auto Start/Stop settings when using remote two-wire control.	<ul style="list-style-type: none"> Auto Start/Stop should only be used in remote mode with three-wire or four-wire control.
Non-resettable Thermistor Cct trip, when there is a link between the thermistor input B4, B5 or when the motor thermistor connected between B4, B5 is permanently removed.	<ul style="list-style-type: none"> The thermistor input is enabled once a link is fitted and short circuit protection has activated. <ul style="list-style-type: none"> Remove the link then load the default parameter set. This will disable the thermistor input and clear the trip. Place a 1k2 Ω resistor across the thermistor input. Turn thermistor protection to 'Log only' (parameter 16I).
Remote start/stop command is overriding Auto Start/Stop settings when using remote two-wire control.	<ul style="list-style-type: none"> Auto Start/Stop should only be used in remote mode with three-wire or four-wire control.
The soft starter does not control the motor correctly during starting.	<ul style="list-style-type: none"> Start performance may be unstable when using a low <i>Motor Full Load Current</i> setting (parameter 1A). Power factor correction (PFC) capacitors must be installed on the supply side of the soft starter and must be disconnected during starting and stopping. To control a dedicated PFC capacitor contactor, connect the contactor to run relay terminals.

Symptom	Probable Cause
Motor does not reach full speed.	<ul style="list-style-type: none"> If the start current is too low, the motor will not produce enough torque to accelerate to full speed. The soft starter may trip on excess start time. <p>NOTE</p>  <p>Make sure the motor starting parameters are appropriate for the application and that you are using the intended motor starting profile. If a programmable input is set to Motor Set Select, check that the corresponding input is in the expected state.</p> <p>The load may be jammed. Check the load for severe overloading or a locked rotor situation.</p>
Erratic motor operation.	<ul style="list-style-type: none"> The SCRs in the WSIQ2 require at least 5 A of current to latch. If you are testing the soft starter on a motor with full load current less than 5 A, the SCRs may not latch correctly.
Erratic and noisy motor operation.	<ul style="list-style-type: none"> If the soft starter is connected to the motor using inside delta configuration, the soft starter may not be correctly detecting the connection. Contact your local supplier for advice.
Soft stop ends too quickly.	<ul style="list-style-type: none"> The soft stop settings may not be appropriate for the motor and load. Review the soft stop settings. If the motor is very lightly loaded, soft stop will have limited effect.
Adaptive Control, brake, jog and PowerThrough functions not working.	<ul style="list-style-type: none"> These features are only available with in-line installation. If the WSIQ2 is installed inside delta, these features will not operate.
After selecting Adaptive Control the motor used an ordinary start and/or the second start was different to the first.	<ul style="list-style-type: none"> The first Adaptive Control start is actually 'Constant Current' so that the starter can learn from the motor characteristics. Subsequent starts use Adaptive Control.
PowerThrough does not operate when selected.	<ul style="list-style-type: none"> The starter will trip on Lx-Tx Shorted on the first start attempt after control power is applied. PowerThrough will not operate if control power is cycled between starts.
Starter "awaiting data"	<ul style="list-style-type: none"> The keypad is not receiving data from the control PCB. Check the cable connection and the fitting of the display on the starter.
Corrupted text shown on keypad display.	<ul style="list-style-type: none"> The keypad may not be screwed down, resulting in an intermittent connection. Screw down the keypad or hold squarely in place.
Display is distorted	<ul style="list-style-type: none"> Check that the keypad has not been screwed down too tightly. Loosen screws slightly.
Parameter settings cannot be stored.	<ul style="list-style-type: none"> Make sure you are saving the new value by pressing the STORE button after adjusting a parameter setting. If you press RESET/EXIT, the change will not be saved. Check that the adjustment lock (parameter 15B) is set to <i>Read & Write</i>. If the adjustment lock is set to <i>Read Only</i>, settings can be viewed but not changed. You need to know the security access code to change the adjustment lock setting. The EEPROM may be faulty on the keypad. A faulty EEPROM will also trip the soft starter, and the keypad will display the message Parameter out of range. Contact your local supplier for advice.
ATTENTION! Remove Mains Volts	<ul style="list-style-type: none"> The soft starter will not activate Run Simulation with three-phase power connected. This prevents unintentional direct on-line (DOL) start.

14 Appendix

14.1 Specifications

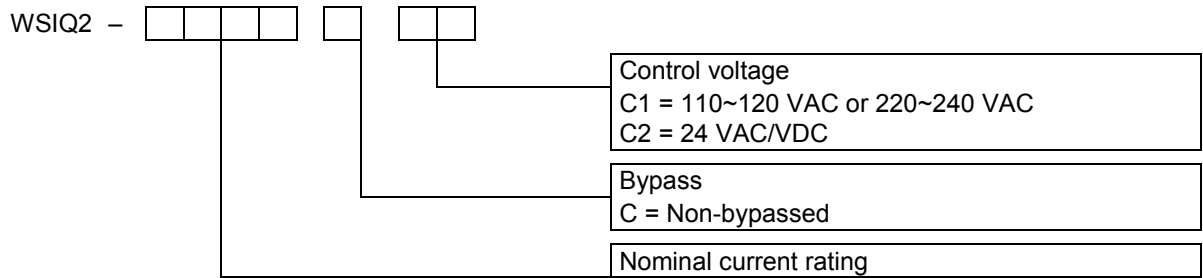

Current Ratings

- IEC ratings

Current Ratings for Bypass Operation

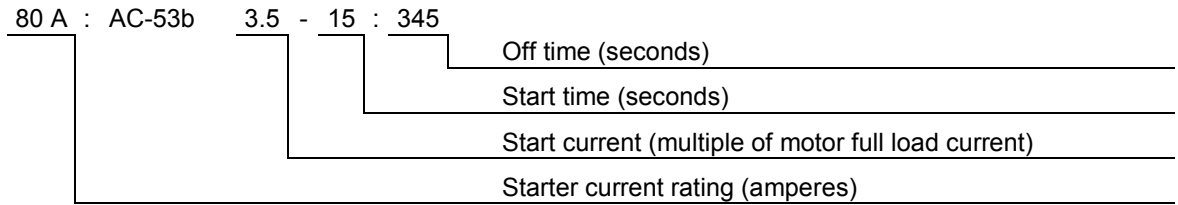

In-line connection

	AC53b 3.0-10:590 40 °C <1000 metres	AC53b 3.5-15:585 40 °C <1000 metres	AC53b 4.0-20:580 40 °C <1000 metres	AC53b 4.5-30:570 40 °C <1000 metres
WSIQ2-0360C	360 A	360 A	310 A	263 A
WSIQ2-0380C	380 A	380 A	359 A	299 A
WSIQ2-0430C	430 A	430 A	368 A	309 A
WSIQ2-0620C	620 A	620 A	540 A	438 A
WSIQ2-0650C	650 A	650 A	561 A	455 A
WSIQ2-0790C	790 A	790 A	714 A	579 A
WSIQ2-0930C	930 A	930 A	829 A	661 A
WSIQ2-1200C	1200 A	1200 A	1200 A	1071 A
WSIQ2-1410C	1410 A	1410 A	1319 A	1114 A
WSIQ2-1600C	1600 A	1600 A	1600 A	1353 A

Inside delta connection

	AC53b 3.0-10:590 40 °C <1000 metres	AC53b 3.5-15:585 40 °C <1000 metres	AC53b 4.0-20:580 40 °C <1000 metres	AC53b 4.5-30:570 40 °C <1000 metres
WSIQ2-0360C	540 A	540 A	465 A	395 A
WSIQ2-0380C	570 A	570 A	539 A	449 A
WSIQ2-0430C	645 A	645 A	552 A	464 A
WSIQ2-0620C	930 A	930 A	810 A	651 A
WSIQ2-0650C	975 A	975 A	842 A	683 A
WSIQ2-0790C	1185 A	1185 A	1075 A	868 A
WSIQ2-0930C	1395 A	1395 A	1244 A	992 A
WSIQ2-1200C	1800 A	1800 A	1800 A	1606 A
WSIQ2-1410C	2115 A	2115 A	1979 A	1671 A
WSIQ2-1600C	2400 A	2400 A	2400 A	2030 A

Current Ratings for Continuous Operation (Not bypassed)

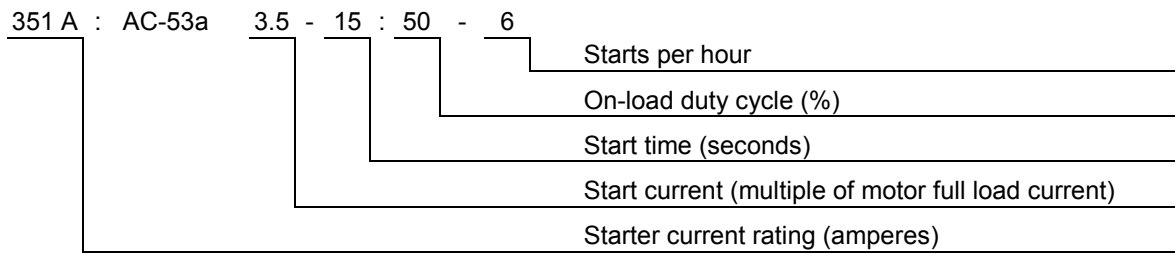

In-line connection

	AC53a 3-10:50-6 40 °C <1000 metres	AC53a 3.5-15:50-6 40 °C <1000 metres	AC53a 4-20:50-6 40 °C <1000 metres	AC53a 4.5-30:50-6 40 °C <1000 metres
WSIQ2-0360C	360 A	351 A	303 A	259 A
WSIQ2-0380C	380 A	380 A	348 A	292 A
WSIQ2-0430C	430 A	413 A	355 A	301 A
WSIQ2-0620C	620 A	614 A	515 A	419 A
WSIQ2-0650C	650 A	629 A	532 A	437 A
WSIQ2-0790C	790 A	790 A	694 A	567 A
WSIQ2-0930C	930 A	930 A	800 A	644 A
WSIQ2-1200C	1200 A	1200 A	1135 A	983 A
WSIQ2-1410C	1410 A	1355 A	1187 A	1023 A
WSIQ2-1600C	1600 A	1600 A	1433 A	1227 A

Inside delta connection

	AC53a 3-10:50-6 40 °C <1000 metres	AC53a 3.5-15:50-6 40 °C <1000 metres	AC53a 4-20:50-6 40 °C <1000 metres	AC53a 4.5-30:50-6 40 °C <1000 metres
WSIQ2-0360C	540 A	527 A	455 A	388 A
WSIQ2-0380C	570 A	570 A	522 A	437 A
WSIQ2-0430C	645 A	620 A	533 A	451 A
WSIQ2-0620C	930 A	920 A	773 A	628 A
WSIQ2-0650C	975 A	943 A	798 A	656 A
WSIQ2-0790C	1185 A	1185 A	1041 A	850 A
WSIQ2-0930C	1395 A	1395 A	1200 A	966 A
WSIQ2-1200C	1800 A	1800 A	1702 A	1474 A
WSIQ2-1410C	2115 A	2033 A	1780 A	1535 A
WSIQ2-1600C	2400 A	2400 A	2149 A	1840 A

- NEMA motor ratings**

In-line connection

	Light 300%, 10 seconds 50 °C <1000 metres	Standard 350%, 30 seconds 50 °C <1000 metres	Heavy 450%, 30 seconds 50 °C <1000 metres
WSIQ2-0360C	360 A	302 A	242 A
WSIQ2-0380C	380 A	341 A	272 A
WSIQ2-0430C	430 A	360 A	302 A
WSIQ2-0620C	620 A	493 A	394 A
WSIQ2-0650C	650 A	515 A	414 A
WSIQ2-0790C	790 A	661 A	527 A
WSIQ2-0930C	930 A	751 A	597 A
WSIQ2-1200C	1200 A	1148 A	932 A
WSIQ2-1410C	1410 A	1200 A	979 A
WSIQ2-1600C	1600 A	1444 A	1181 A

Inside delta connection

	Light 300%, 10 seconds 50 °C <1000 metres	Standard 350%, 30 seconds 50 °C <1000 metres	Heavy 450%, 30 seconds 50 °C <1000 metres
WSIQ2-0360C	540 A	453 A	363 A
WSIQ2-0380C	570 A	511 A	408 A
WSIQ2-0430C	645 A	540 A	453 A
WSIQ2-0620C	930 A	739 A	591 A
WSIQ2-0650C	975 A	772 A	621 A
WSIQ2-0790C	1185 A	991 A	790 A
WSIQ2-0930C	1395 A	1126 A	895 A
WSIQ2-1200C	1800 A	1722 A	1398 A
WSIQ2-1410C	2115 A	1800 A	1468 A
WSIQ2-1600C	2400 A	2166 A	1771 A

Minimum and Maximum Current Settings

The WSIQ2's minimum and maximum full load current settings depend on the model:

Model	In-line connection		Inside delta connection	
	Minimum	Maximum	Minimum	Maximum
WSIQ2-0360C	72 A	360 A	72 A	540 A
WSIQ2-0380C	76 A	380 A	76 A	570 A
WSIQ2-0430C	86 A	430 A	86 A	645 A
WSIQ2-0620C	124 A	620 A	124 A	930 A
WSIQ2-0650C	130 A	650 A	130 A	975 A
WSIQ2-0790C	158 A	790 A	158 A	1185 A
WSIQ2-0930C	186 A	930 A	186 A	1395 A
WSIQ2-1200C	240 A	1200 A	240 A	1800 A
WSIQ2-1410C	282 A	1410 A	282 A	2115 A
WSIQ2-1600C	320 A	1600 A	320 A	2400 A

Dimensions and Weights

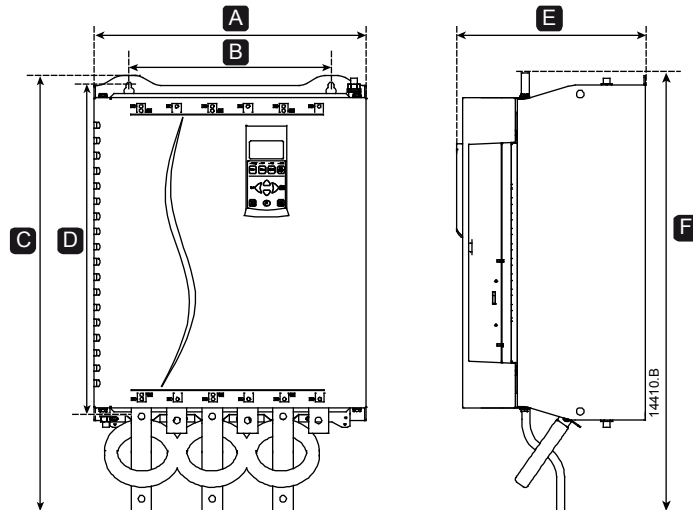

Model	A mm (inch)	B mm (inch)	C mm (inch)	D mm (inch)	E mm (inch)	F mm (inch)	Weight kg (lb)
WSIQ2-0360C	430 (17.0)	320 (12.6)	689 (27.2)	522 (20.6)	300 (11.9)	696 (27.5)	36 (79.4)
WSIQ2-0380C							39.5 (87.1)
WSIQ2-0430C							
WSIQ2-0620C							
WSIQ2-0650C							
WSIQ2-0790C							51.5 (113.5)
WSIQ2-0930C							
WSIQ2-1200C	574 (22.6)	500 (19.7)	856 (33.8)	727 (28.7)	361 (14.3)	862 (34.0)	128.5 (283.3)
WSIQ2-1410C							130 (286.6)
WSIQ2-1600C							140 (308.6)



NOTE

Dimension C is the height when input and output busbars are at the same end of the unit (top in/top out or bottom in/bottom out).

Dimension F applies for either top in/bottom out or bottom in/top out configuration.

Specifications

• Supply

Mains voltage (L1, L2, L3) 380~690 VAC ($\pm 10\%$)

Control voltage (A1, A2, A3)

WSIQ2-xxxxC (A1, A2)..... 110~210 VAC (+ 10% / -15%), 600 mA

WSIQ2-xxxxC (A2, A3)..... 220~440 VAC (+ 10% / -15%), 600 mA

WSIQ2-xxxxC-**24** (A1, A3)..... 24 VAC/VDC ($\pm 20\%$), 100 VA

Mains frequency 45 Hz ~ 66 Hz

Rated insulation voltage to earth 600 VAC

Rated impulse withstand voltage 6 kV

Form designation Bypassed or continuous, semiconductor motor starter form 1

• Short circuit capability

Coordination with semiconductor fuses..... Type 2

Coordination with HRC fuses Type 1

WSIQ2-0360C ~ WSIQ2-0930C prospective current 100 kA

WSIQ2-1200C ~ WSIQ2-1600C prospective current 85 kA

• Electromagnetic capability (compliant with EU Directive 2014/35/EU)

EMC Immunity IEC 60947-4-2

EMC Emissions IEC 60947-4-2 Class A¹ and Lloyds Marine No 1 Specification

¹ This product has been designed as Class A equipment. Use of this product in domestic environments may cause radio interference, in which case the user may be required to employ additional mitigation methods.

• **Inputs**

Input rating	Active 24 VDC, 8 mA approx
Start (C23, C24)	Normally Open
Stop (C31, C32)	Normally Closed
Reset (C41, C42)	Normally Closed
Programmable inputs	
Input A (C53, C54)	Normally Open
Input B (C63, C64)	Normally Open
Motor thermistor (B4, B5)	Trip >3.6 kΩ, reset <1.6 kΩ
PT100 RTD (B6, B7, B8)	Accuracy 0 ~ 100 °C ± 0.5 °C, 100 °C ~ 150 °C ± 2 °C, -20 ~ 0 °C ± 2 °C

• **Outputs**

Relay outputs	10 A @ 250 VAC resistive, 5A @ 250 VAC AC15 pf 0.3
Run relay (23, 24)	Normally Open
Programmable outputs	
Relay A (13, 14)	Normally Open
Relay B (31, 32, 34)	Changeover
Relay C (41, 42, 44)	Changeover
Analog output (B10, B11)	0-20 mA or 4-20 mA (selectable)
Maximum load	600 Ω (12 VDC @ 20 mA)
Accuracy	± 5%
24 VDC output (P24, COM)	
Maximum load	200 mA
Accuracy	± 10%

• **Environmental**

Protection	IP00
Keypad (when installed with remote mounting kit)	IP65 & NEMA12
Operating temperature	-10 °C~60 °C, above 40 °C with derating
Storage temperature	-25 °C~+ 60 °C
Operating Altitude	0~1000 m, above 1000 m with derating
Humidity	5%~95% Relative Humidity
Pollution degree	Pollution Degree 3
Vibration	IEC 60068-2-6

• **Heat Dissipation**

During Start	4.5 watts per ampere
During Run	4.5 watts per ampere approx

• **Certification**

UL / C-UL	UL 508*
.....	IP00, UL Indoor Open Type
CE	EN 60947-4-2
CCC	GB 14048.6
RoHS	Compliant with EU Directive 2011/65/EU

* For UL certification additional requirements may apply, depending on the models. For details, refer to UL Compliant Installation on page 80.

UL Compliant Installation

For UL-compliant installation:

- Use the recommended pressure terminal/connector kit (refer to table below).
- Refer to *UL Fuse Selection and Short Circuit Ratings* on page 16.

UL compliant installation - Terminal/Connector parts

Models	FLC (A)	No. of wires	Recommended lugs part No.
WSIQ2-0360C	360	2	1 x 600T-2
WSIQ2-0380C	380		
WSIQ2-0430C	430		
WSIQ2-0620C	620		
WSIQ2-0650C	650		
WSIQ2-0790C	790	4	2 x 600T-2
WSIQ2-0930C	930	3	2 x 600T-2
WSIQ2-1200C	1200	4	1 x 750T-4
WSIQ2-1410C	1410		
WSIQ2-1600C	1600	5	1 x 750T-4 1 x 600T-3

14.2 Disposal Instructions

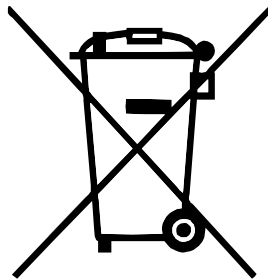

Equipment containing electrical components may not be disposed of together with domestic waste.

It must be collected separately as electrical and electronic waste according to local and currently valid legislation.

14.3 Accessories

Communication Modules

WSIQ2 soft starters support network communication via easy-to-install communications modules. Each soft starter can support one communications module at a time.

Available protocols:

Ethernet (Profinet, Modbus TCP, Ethernet/IP), Profibus, DeviceNet, Modbus RTU, and USB.

Expansion Cards

The WSIQ2 offers expansion cards for users requiring additional inputs and outputs or advanced functionality. Each WSIQ2 can support a maximum of one expansion card.

• Input/Output

The input/output expansion card provides the following additional inputs and outputs:

- 2 x digital inputs
- 3 x output relays
- 1 x analog input
- 1 x analog output

• RTD/Ground Fault

The RTD/PT100 and ground fault protection card provides the following additional inputs:

- 6 x PT100 RTD inputs
- 1 x ground fault input

To use ground fault protection a 1000:1, 5 VA current transformer is also required.

Keypad Mounting Kit

The keypad mounting kit allows remote mounting of the keypad up to 3 m away from the soft starter. Different kits are available with two or three metre cables.

PC Software

WORLDStart Visual PC software provides monitoring, programming and control of up to 99 soft starters.

A Modbus or USB communication module is required for each starter to use WORLDStart Visual.

14.4 Parameter Values

If you require assistance from your supplier or a service technician, please note all parameter settings in the table below.

1	Motor Data-1	User Set 1	User Set 2
1A	<i>Motor Full Load Current</i>		
1B	<i>Locked Rotor Time</i>		
1C	<i>Locked Rotor Current</i>		
1D	<i>Motor Service Factor</i>		
2	Start/Stop Modes-1		
2A	<i>Start Mode</i>		
2B	<i>Start Ramp Time</i>		
2C	<i>Initial Current</i>		
2D	<i>Current Limit</i>		
2E	<i>Adaptive Start Profile</i>		
2F	<i>Kickstart Time</i>		
2G	<i>Kickstart Level</i>		
2H	<i>Stop Mode</i>		
2I	<i>Stop Time</i>		
2J	<i>Adaptive Stop Profile</i>		
2K	<i>Adaptive Control Gain</i>		
2L	<i>Brake Torque</i>		
2M	<i>Brake Time</i>		
3	Auto-Start/Stop		
3A	<i>Auto-Start Type</i>		
3B	<i>Auto-Start Time</i>		
3C	<i>Auto-Stop Type</i>		
3D	<i>Auto-Stop Time</i>		
4	Protection Settings		
4A	<i>Excess Start Time</i>		
4B	<i>Excess Start Time-2</i>		
4C	<i>Undercurrent</i>		
4D	<i>Undercurrent Delay</i>		
4E	<i>Instantaneous Overcurrent</i>		
4F	<i>Instantaneous Overcurrent Delay</i>		
4G	<i>Phase Sequence</i>		
4H	<i>Current Imbalance</i>		
4I	<i>Current Imbalance Delay</i>		
4J	<i>Frequency Check</i>		
4K	<i>Frequency Variation</i>		
4L	<i>Frequency Delay</i>		
4M	<i>Restart Delay</i>		
4N	<i>Motor Temperature Check</i>		
4O	<i>Ground Fault Level</i>		
4P	<i>Ground Fault Delay</i>		
4Q	<i>Reserved</i>		
4R	<i>Reserved</i>		
4S	<i>Reserved</i>		
4T	<i>Reserved</i>		
5	Auto-Reset Trips		
5A	<i>Auto-Reset Action</i>		
5B	<i>Maximum Resets</i>		
5C	<i>Reset Delay Groups A&B</i>		
5D	<i>Reset Delay Group C</i>		
6	Inputs		
6A	<i>Input A Function</i>		
6B	<i>Input A Name</i>		
6C	<i>Input A Trip</i>		
6D	<i>Input A Trip Delay</i>		
6E	<i>Input A Initial Delay</i>		

6F	<i>Input B Function</i>		
6G	<i>Input B Name</i>		
6H	<i>Input B Trip</i>		
6I	<i>Input B Trip Delay</i>		
6J	<i>Input B Initial Delay</i>		
6K	<i>Input C Function</i>		
6L	<i>Input D Function</i>		
6M	<i>Remote Reset Logic</i>		
6N	<i>Analog Input Trip</i>		
6O	<i>Analog Input Scale</i>		
6P	<i>Analog Trip Point</i>		
6Q	<i>Local/Remote</i>		
6R	<i>Comms in Remote</i>		
7	Outputs		
7A	<i>Relay A Function</i>		
7B	<i>Relay A On Delay</i>		
7C	<i>Relay A Off Delay</i>		
7D	<i>Relay B Function</i>		
7E	<i>Relay B On Delay</i>		
7F	<i>Relay B Off Delay</i>		
7G	<i>Relay C Function</i>		
7H	<i>Relay C On Delay</i>		
7I	<i>Relay C Off Delay</i>		
7J	<i>Relay D Function</i>		
7K	<i>Relay E Function</i>		
7L	<i>Relay F Function</i>		
7M	<i>Low Current Flag</i>		
7N	<i>High Current Flag</i>		
7O	<i>Motor Temperature Flag</i>		
7P	<i>Analog Output A</i>		
7Q	<i>Analog A Scale</i>		
7R	<i>Analog A Maximum Adjustment</i>		
7S	<i>Analog A Minimum Adjustment</i>		
7T	<i>Analog Output B</i>		
7U	<i>Analog B Scale</i>		
7V	<i>Analog B Maximum Adjustment</i>		
7W	<i>Analog B Minimum Adjustment</i>		
8	Display		
8A	<i>Language</i>		
8B	<i>F1 Button Action</i>		
8C	<i>F2 Button Action</i>		
8D	<i>Display A or kW</i>		
8E	<i>User Screen - Top Left</i>		
8F	<i>User Screen - Top Right</i>		
8G	<i>User Screen - Bottom Left</i>		
8H	<i>User Screen - Bottom Right</i>		
8I	<i>Graph Data</i>		
8J	<i>Graph Timebase</i>		
8K	<i>Graph Maximum Adjustment</i>		
8L	<i>Graph Minimum Adjustment</i>		
8M	<i>Current Calibration</i>		
8N	<i>Mains Reference Voltage</i>		
8O	<i>Voltage Calibration</i>		
9	Motor Data-2		
9A	<i>Dual Thermal Model</i>		
9B	<i>Motor FLC-2</i>		
9C	<i>Locked Rotor Time-2</i>		
9D	<i>Locked Rotor Current-2</i>		
9E	<i>Motor Service Factor-2</i>		

10	Start/Stop Modes-2		
10A	<i>Start Mode-2</i>		
10B	<i>Start Ramp-2</i>		
10C	<i>Initial Current-2</i>		
10D	<i>Current Limit-2</i>		
10E	<i>Adaptive Start Profile-2</i>		
10F	<i>Kickstart Time-2</i>		
10G	<i>Kickstart Level-2</i>		
10H	<i>Stop Mode-2</i>		
10I	<i>Stop Time-2</i>		
10J	<i>Adaptive Stop Profile-2</i>		
10K	<i>Adaptive Control Gain-2</i>		
10L	<i>Brake Torque-2</i>		
10M	<i>Brake Time-2</i>		
11	RTD Temperatures		
11A	<i>RTD/PT100 A °C</i>		
11B	<i>RTD/PT100 B °C</i>		
11C	<i>RTD/PT100 C °C</i>		
11D	<i>RTD/PT100 D °C</i>		
11E	<i>RTD/PT100 E °C</i>		
11F	<i>RTD/PT100 F °C</i>		
11G	<i>RTD/PT100 G °C</i>		
12	Slip-Ring Motors		
12A	<i>Motor Data-1 Ramp</i>		
12B	<i>Motor Data-2 Ramp</i>		
12C	<i>Changeover Time</i>		
12D	<i>Slip Ring Retard</i>		
15	Advanced		
15A	<i>Access Code</i>		
15B	<i>Adjustment Lock</i>		
15C	<i>Emergency Run</i>		
15D	<i>Shorted SCR Action</i>		
16	Protection Action		
16A	<i>Motor Overload</i>		
16B	<i>Excess Start Time</i>		
16C	<i>Undercurrent</i>		
16D	<i>Instantaneous Overcurrent</i>		
16E	<i>Current Imbalance</i>		
16F	<i>Frequency</i>		
16G	<i>Input A Trip</i>		
16H	<i>Input B Trip</i>		
16I	<i>Motor Thermistor</i>		
16J	<i>Starter Communication</i>		
16K	<i>Network Communication</i>		
16L	<i>Heatsink Overtemperature</i>		
16M	<i>Battery/Clock</i>		
16N	<i>Ground Fault</i>		
16O	<i>RTD/PT100 A</i>		
16P	<i>RTD/PT100 B</i>		
16Q	<i>RTD/PT100 C</i>		
16R	<i>RTD/PT100 D</i>		
16S	<i>RTD/PT100 E</i>		
16T	<i>RTD/PT100 F</i>		
16U	<i>RTD/PT100 G</i>		
16V	<i>Reserved</i>		
16W	<i>Reserved</i>		
16X	<i>Low Control Volts</i>		
20	Restricted		

15 Busbar Adjustment Procedure

The busbars on non-bypassed models WSIQ2-0360C ~ WSIQ2-1600C can be adjusted for top or bottom input and output as required.



NOTE

Many electronic components are sensitive to static electricity. Voltages so low that they cannot be felt, seen or heard, can reduce the life, affect performance, or completely destroy sensitive electronic components. When performing service, proper ESD equipment should be used to prevent possible damage from occurring.

All units are manufactured with input and output busbars at the bottom of the unit as standard. The input and/or output busbars can be moved to the top of the unit if required.

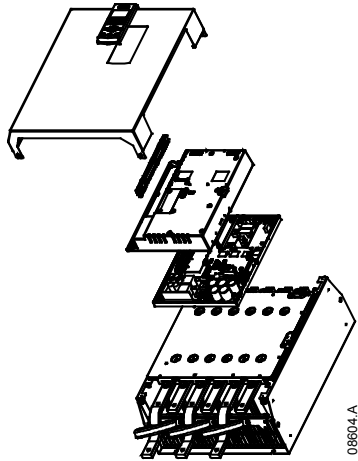

1. Remove all wiring and links from the soft starter before dismantling the unit.
2. Remove the unit cover (4 screws).
3. Remove the keypad faceplate, then gently remove the keypad (2 screws).
4. Remove the control terminal plugs.
5. Gently fold the main plastic away from the starter (12 screws).
6. Unplug the keypad loom from CON 1 (see note).
7. Label each SCR firing loom with the number of the corresponding terminal on the backplane PCB, then unplug the looms.
8. Unplug the thermistor, fan and current transformer wires from the model board.
9. Remove the plastic tray from the starter (four screws).



NOTE

Remove the main plastic slowly to avoid damaging the keypad wiring loom which runs between the main plastic and the backplane PCB.

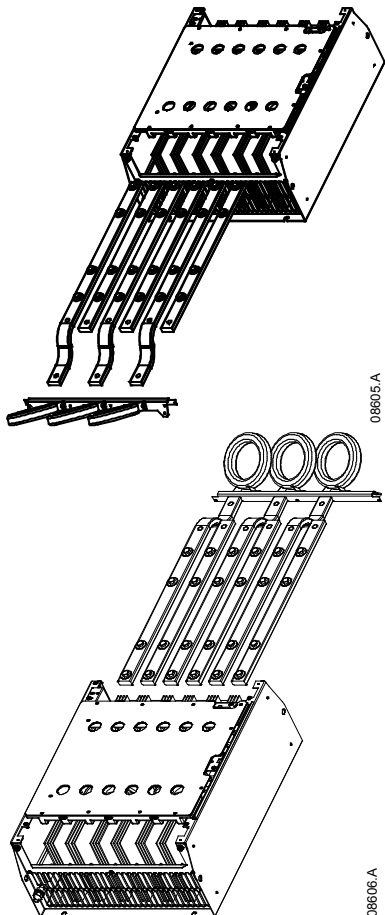

10. Unscrew and remove the magnetic bypass plates (models WSIQ2-0620C to WSIQ2-1600C only).
11. Remove the current transformer assembly (three screws).
12. Identify which busbars are to be moved. Remove the bolts holding these busbars in place then slide the busbars out through the bottom of the starter (four bolts per busbar).
13. Slide the busbars in through the top of the starter. For input busbars, the short curved end should be outside the starter. For output busbars, the unthreaded hole should be outside the starter.
14. Replace the dome washers with the flat face towards the busbar, then tighten the bolts holding the busbars in place to 20 Nm.
15. Place the current transformer assembly over the input busbars and screw the assembly to the body of the starter (see note).
16. Run all wiring to the side of the starter and secure with cable ties.

**NOTE**

If moving the input busbars, the current transformers (CTs) must also be reconfigured.

1. Label the CTs L1, L2 and L3 (L1 is leftmost when looking from the front of the starter). Remove the cable ties and unscrew the CTs from the bracket.
2. Move the CT bracket to the top of the starter. Position the CTs for the correct phases, then screw the CTs to the bracket. For models WSIQ2-0360C ~ WSIQ2-0930C, the CTs must be placed on an angle (the left hand legs of each CT will be on the top row of holes and the right hand legs will be on the bottom tabs).

