



INSTRUCTIONS

PROFINET MODULE

for use with WSE/WSIQ2

WorldWide Electric Corporation
Phone: 1-800-808-2131
Fax: 1-800-711-1616
www.worldwideelectric.net

Compatibility

This communications module is suitable for use with:

- WSE Compact soft starter
- WSIQ2 Advanced soft starter



NOTE

The Profinet Module is not suitable for use with WSE soft starters using 380/440 VAC control voltage.

This manual applies to PIM-PN-02.

The part number is printed on a label on the front of the device. For PIM-PN-01, the manual is available from your local supplier.

Contents

1	Introduction	2
2	Installation	3
3	Device configuration	5
4	Master configuration	9
5	Operation	9
6	Packet structures	10
7	Network design.....	17
8	Specifications	19

Disclaimer

The examples and diagrams in this manual are included solely for illustrative purposes. The information contained in this manual is subject to change at any time and without prior notice. In no event will responsibility or liability be accepted for direct, indirect or consequential damages resulting from the use or application of this equipment.

Failure to follow the information and instructions in this manual will void the warranty.

Warnings

It is the installer's responsibility to follow all instructions in this manual and to follow correct electrical practice.



WARNING

For your safety, isolate the soft starter completely from mains voltage before attaching or removing accessories.



WARNING

Observe all necessary safety precautions when controlling the soft starter remotely. Alert personnel that machinery may start without warning.

1 Introduction

1.1 Product design

The Profinet Module allows the soft starter to connect to an Ethernet network and be controlled or monitored using an Ethernet communication model.

Familiarity with Ethernet protocols and networks is required to operate the device successfully. For difficulties using this device with third party products, including PLCs, scanners and commissioning tools, contact the relevant supplier.

1.2 Communication protocols

The Profinet Module supports the following protocols:

Profinet	Industrial ethernet via Profinet
MQTT	Message Queue Telemetry Transport
OPC UA	Open Platform Communications Unified Architecture

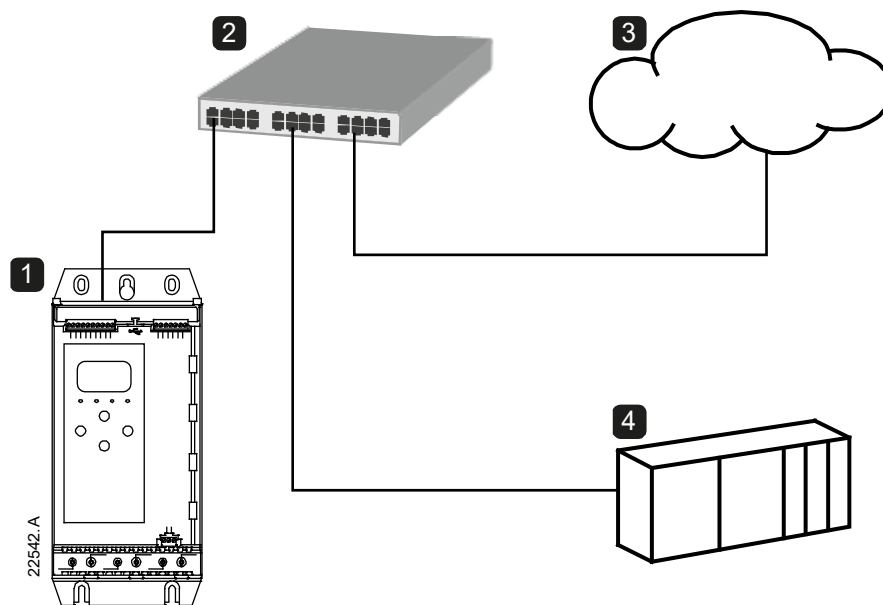

1	Soft starter
2	Network switch
3	IoT connection (MQTT/OPC UA)
4	Industrial ethernet connection to programmable logic controller

2 Installation



CAUTION

Remove mains and control voltage from the soft starter before attaching or removing accessories. Failure to do so may damage the equipment.

2.1 Installation procedure

1. Remove control power and mains supply from the soft starter.
2. Fully pull out the top and bottom retaining clips on the module. [A]
3. Line up the module with the comms port slot. [B]
4. Push in the top and bottom retaining clips to secure the module to the starter. [C]
5. Connect Ethernet Port 1 or Port 2 on the Profinet Module to the network.
6. Apply control power to the soft starter.

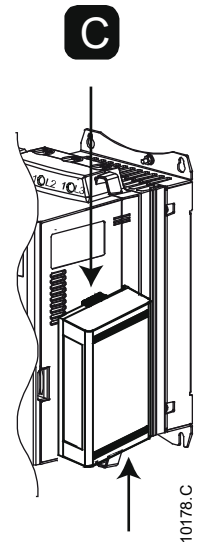
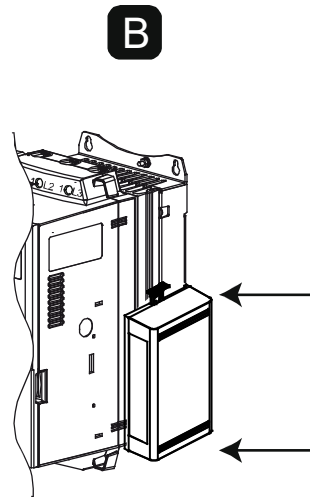
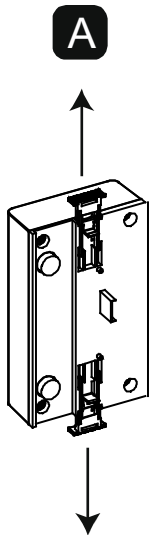

10178.C

To remove the module:

1. Remove control power and mains supply from the soft starter.
2. Disconnect all external wiring from the module.
3. Fully pull out the top and bottom retaining clips on the module. [A]
4. Pull the module away from the soft starter.

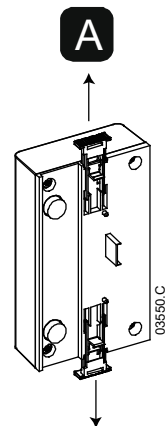

03550.C

2.2 Soft starter connection

The device is powered from the soft starter.

The Profinet Module is not suitable for use with compact soft starters using 380/440 VAC control voltage.

Compact soft starter		Advanced soft starter	
1	Soft starter A1, 02: Stop input	1	Soft starter (remote mode) C31, C32: Stop input C41, C42: Reset input
2	Profinet Module	2	Profinet Module
3	RJ45 Ethernet ports	3	RJ45 Ethernet ports

2.3 Network connection

Ethernet ports

The device has two Ethernet ports. If only one connection is required, either port can be used.

Cables

Use Category 5, 5e, 6 or 6e cable to connect to the device.

EMC precautions

To minimise electromagnetic interference, Ethernet cables should be separated from motor and mains cables by 200 mm.

If the Ethernet cable must cross motor or mains cables, the crossing should be at an angle of 90°.

2.4 Network establishment

The controller must establish communications directly with each device before the device can participate in the network.

2.5 Addressing

Each device in a network is addressed using a MAC address and a device name. The MAC address is fixed within the device and is printed on a label on the front of the device.

3 Device configuration

3.1 Configure the device name

Use the Ethernet Device Configuration Tool to configure the device name. The Ethernet Device Configuration Tool is available from your local supplier.

To identify the device using the Ethernet Device Configuration Tool:

1. Attach the module to the soft starter.
2. Connect Ethernet Port 1 or Port 2 on the Profinet Module to the network.
3. Apply control power to the soft starter.
4. Start the Ethernet Device Configuration Tool.
5. Click on Search Devices. The software will search for connected devices.

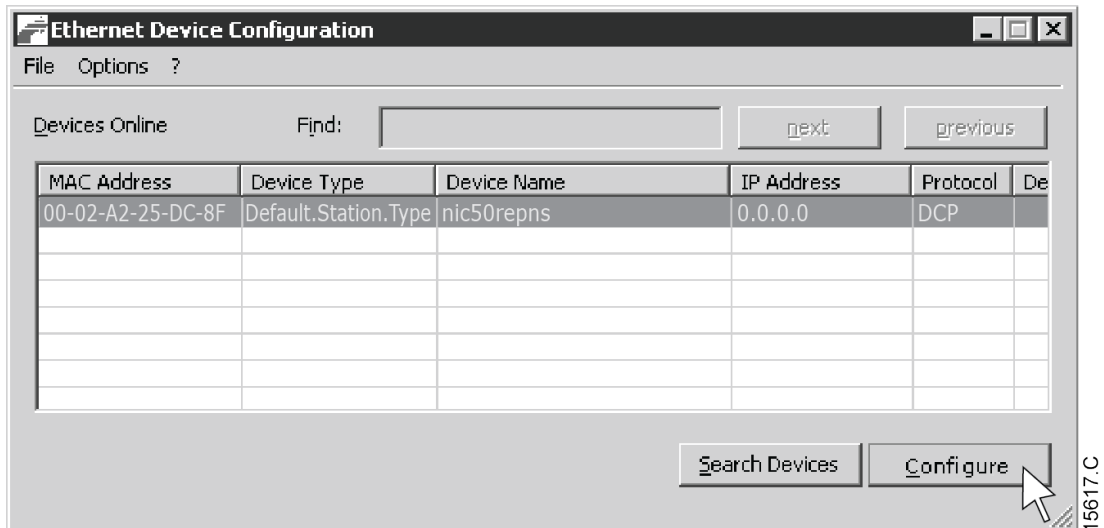

6. To configure a device name, click Configure then select Device Name.

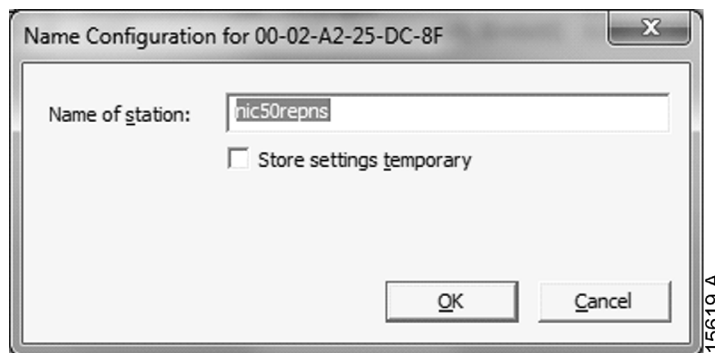

NOTE

The Error LED is on if the device is not configured. If the device is configured but is not passing I/O data, the Error LED will flash. The Error LED will be active during the configuration process.



NOTE

If your PC has a firewall enabled, you must add the tool to the list of authorised programs.

3.2 On-board web server

Other settings in the Profinet Module can be configured via the device’s web server.

Connect to the device

To configure settings using the on-board web server, the module must be installed on a soft starter, control power must be available, and the device and computer must be connected to each other or to the same Ethernet network.

The computer must use a fixed IP address (not DHCP) and the same subnet mask as the device. The default address for a new Profinet Module is 192.168.0.2. The default subnet mask is 255.255.255.0.

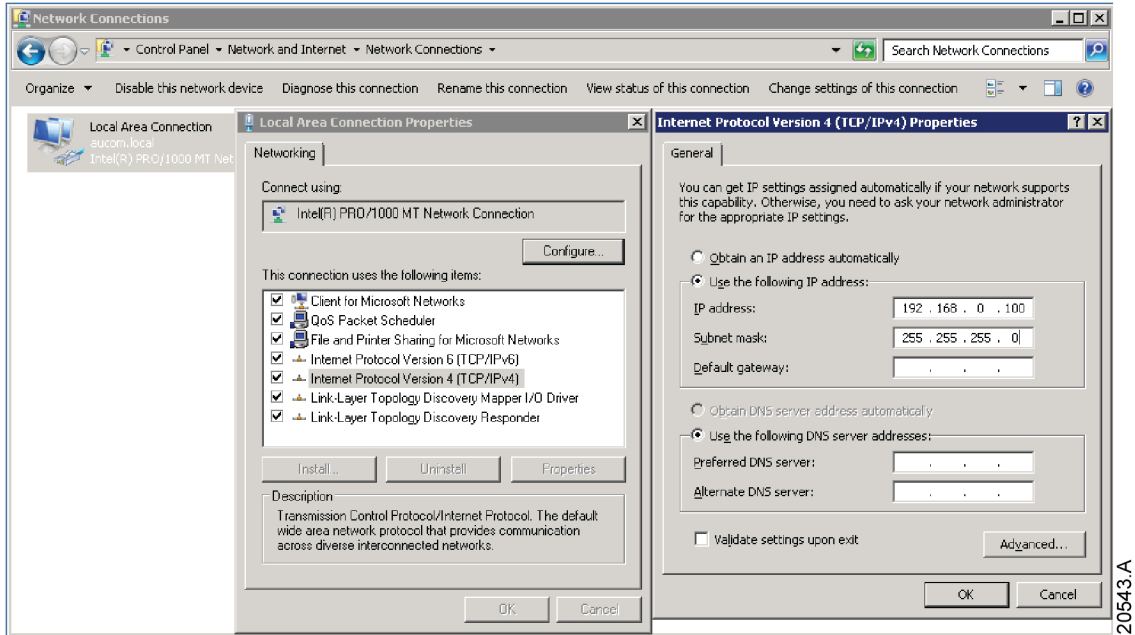

Once connected, the web server reports basic information about the device and the soft starter.

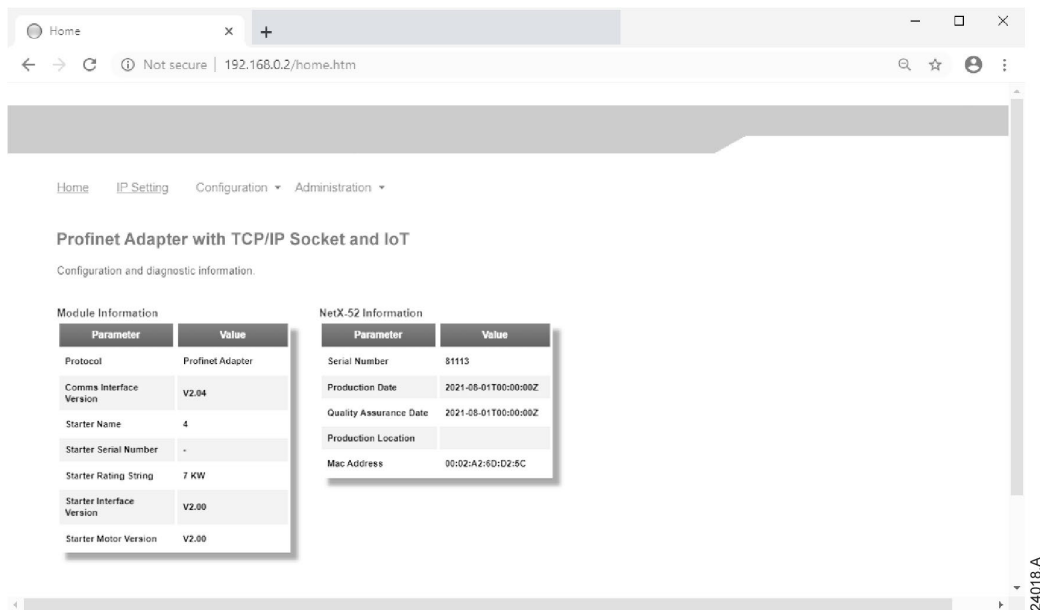

Manage users and passwords

The Profinet Module supports multiple users and levels of privilege.

- Users can view the home screen and IP address settings
- Supervisors can view the home screen and IP settings and can change configuration settings
- Administrators can view the home screen, change configuration settings and add or delete users



NOTE

For security reasons, we recommend that you define a custom administrator ID and password.

The default username and password are:

username: admin

password: 1978

To add a new user:

1. Connect to the web server then click Administration.
2. Click Create new user.
3. Enter the new username and password then click Create an account.
4. Set privileges (user, supervisor, administrator) as appropriate.
5. Click Save changes.

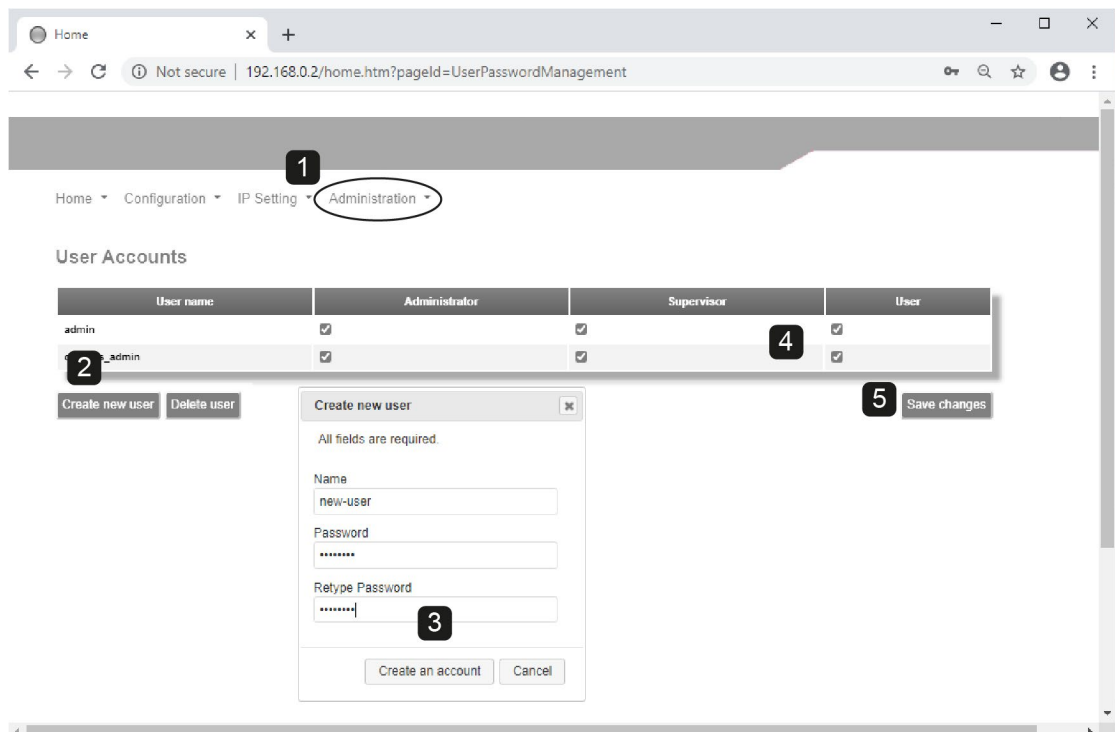

To delete a user:

1. Connect to the web server then click Administration.
2. Click the required entry in the user list then click Delete user. Click Delete again to confirm the action.

Configure IoT settings

The Profinet Module supports soft starter status monitoring over IoT. The device cannot control or program the soft starter.

- **Configure MQTT settings**

1. Connect to the web server then click Configuration > MQTT Client.
2. Tick the Enable checkbox to enable MQTT client operation. The MQTT client is enabled by default.
3. Click Connection then configure the settings as required.
4. Use Connection > Actions to select which information the device will publish.
5. Click Submit to save all settings in the device.

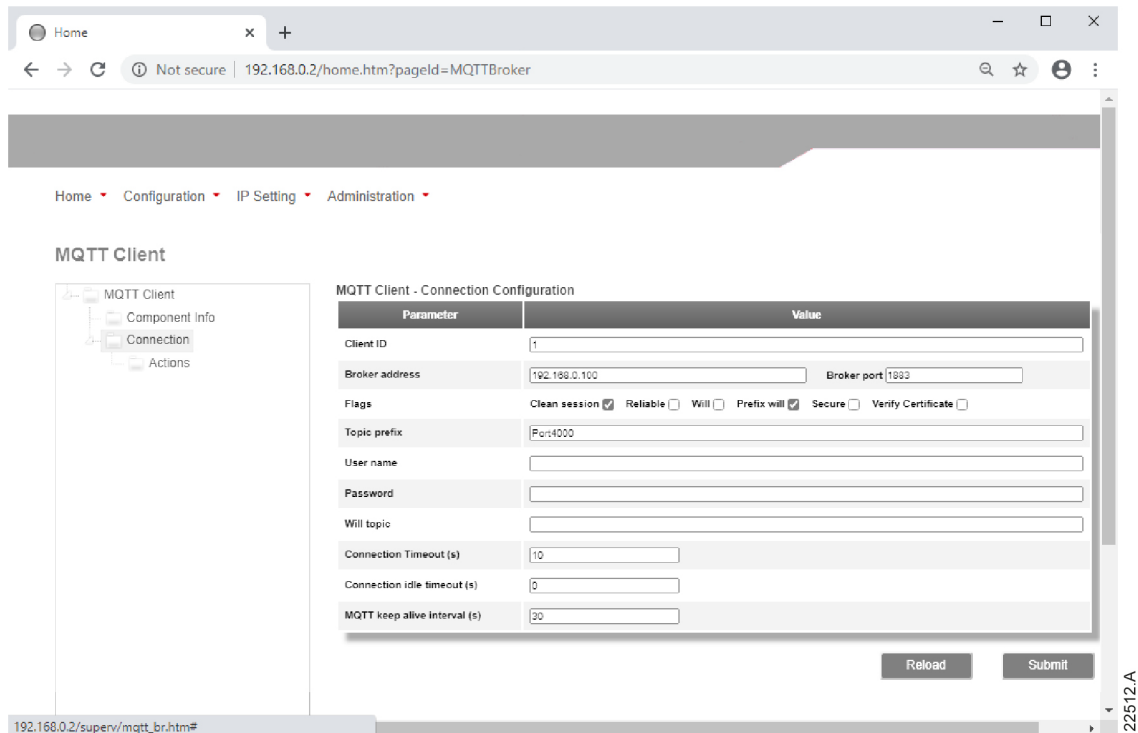

- **Configure OPC UA settings**

1. Connect to the web server then click Configuration > OPC UA Server.
2. Tick the Enable checkbox to enable OPC UA client operation. The OPC UA client is enabled by default.
3. Click Server Configuration then configure the settings as required.
4. Use Actions to select the actions for different object instances.
5. Click Submit to save all settings in the device.

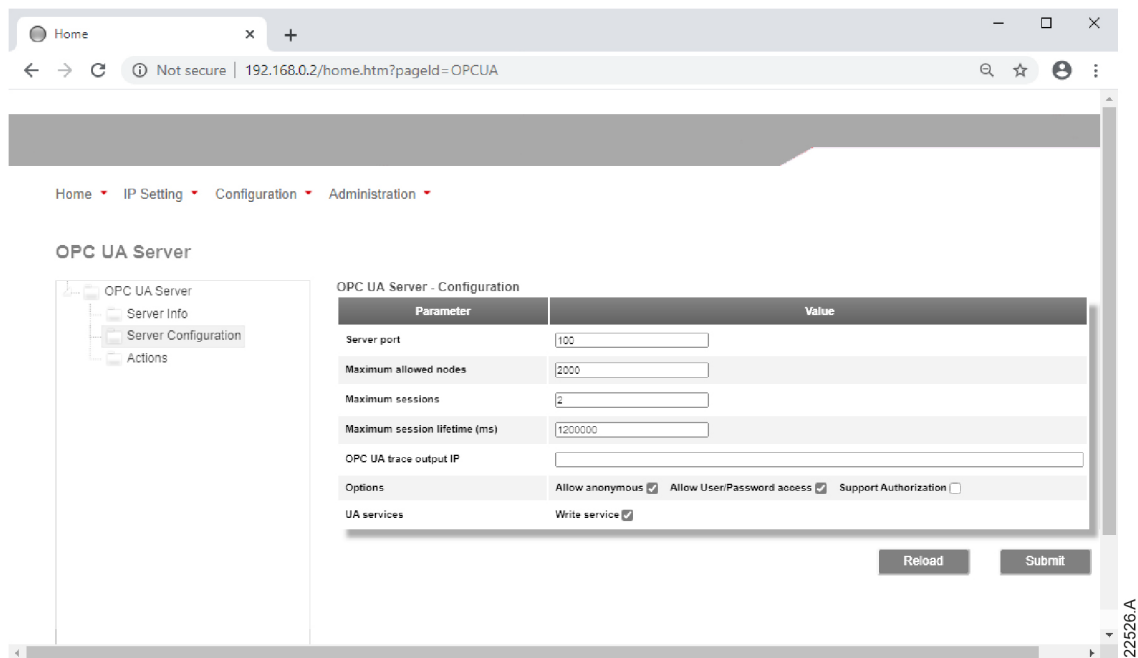

4 Master configuration

Import the latest GSDML file into your Master configuration tool. This file is available from your supplier.

If your Master uses on-screen icons, two graphic bitmap files are available from the website. SSPM_N.bmp indicates normal mode. SSPM_D.bmp indicates diagnostic mode.

5 Operation

The device has been designed for use in a system complying with the Profinet standard. For successful operation, the controller must also support all functions and interfaces described in this document.

5.1 Device classification

The Profinet Card is a Profinet IO-Device and must be managed by an IO-Controller over Ethernet.

5.2 Enabling network control

Compact soft starter: For the soft starter to accept fieldbus commands, a link must be fitted across terminals A1-02 on the starter.

Advanced soft starter: Input links are required across the stop and reset inputs if the soft starter is being operated in Remote mode. In Local mode, links are not required.

Control via the fieldbus communication network is always enabled in local control mode, and can be enabled or disabled in remote control mode (parameter 6R *Comms in Remote*). See the soft starter user manual for parameter details.

5.3 Ensuring safe and successful control

Data written to the device will remain in its registers until the data is overwritten or the device is reinitialised. The device will not transfer successive duplicate commands to the soft starter.

- If the soft starter is started via fieldbus communications but stopped via the keypad or a remote input, an identical start command cannot be used to restart the starter.

- If the soft starter may also be controlled via the keypad or the remote inputs (as well as via fieldbus communications), a control command should be immediately followed by a status query to confirm the command has been actioned.

5.4 Feedback LEDs

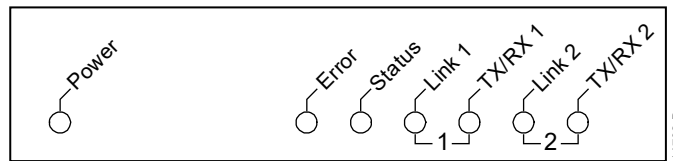

LED name	LED state	Description
Power	Off	Device is not powered up.
	On	Device is receiving power.
Error	Off	No error.
	Flashing	Connection not established.
	On	No physical link or slow physical link. No configuration.
Status	Off	No error.
	Flashing	DCP signal service initiated via the bus.
Link x	Off	No network connection.
	On	Connected to a network.
TX/RX x	Flashing	Transmitting or receiving data.

6 Packet structures



NOTE

Some soft starters do not support some functions.

6.1 Control commands (controller to device)

Use output bytes 0-1 to send a control command to the soft starter.

Byte	Bits	Details
0	0 to 1	<i>Reserved</i>
	2 to 3	0 = Use soft starter remote input to select motor set 1 = Use primary motor set when starting 2 = Use secondary motor set when starting 3 = <i>Reserved</i>
	4	0 = stop action will be as selected in the soft starter 1 = stop action will be a coast to stop
	5 to 7	<i>Reserved</i>
1	0	0 = Stop 1 = Start
	1 to 2	<i>Reserved</i>
	3	1 = Reset
	4 to 7	<i>Reserved</i>
2 to 5		Parameter management (see <i>Parameter management</i> on page 14)



NOTE

Bit 4 of byte 0 must be set to 0 before the soft starter can perform a start.

6.2 Status information (device to controller)

Starter status information is always available when the device is active.

For models 0053B and smaller, current reported via communications is 10 times greater than the actual value (displayed on the keypad).

Bytes 0-1: Control status

Bits	Details
0 to 5	Current (% motor FLC)
6	Local/Remote 0 = Remote control (Network) 1 = Local control (Keypad, Digital Input)
7	1 = Ramping (starting or stopping)
8	1 = Ready
9	1 = Starting, running or stopping
10	1 = Tripped
11	1 = Warning
12 to 15	<i>Reserved</i>

Motor current (% FLC) represents current as a percentage of the set motor full load current. A maximum value of 63 represents 200% full load current. To convert this value to a readable percentage, divide by 0.315.

Bytes 2-3: Starter state

Bits	Details
0 to 3	The decimal value of bits 0~3 indicates the starter's state: 0 = Communication error between device and soft starter 1 = Ready 2 = Starting 3 = Running 4 = Stopping 5 = Not ready (restart delay, restart temperature check, run simulation) 6 = Tripped 7 = Menu open (cannot start) 8 = Jog forward 9 = Jog reverse
4	0 = Negative phase sequence 1 = Positive phase sequence
5	1 = Current exceeds FLC
6	0 = Uninitialised 1 = Initialised
7	1 = Communication error between device and soft starter
8 to 15	<i>Reserved</i>

Bytes 4-5: Trip code

Bits	Details
0 to 15	See <i>Trip codes</i> on page 15

Bytes 6-7: Motor current

Bits	Details
0 to 15	Average rms current across all three phases

Bytes 8-9: Motor temperature

Bits	Details
0 to 15	Motor 1 thermal model (%)

Bytes 10-117: Extended information

Bytes 10~117 report information from the soft starter's internal registers.

Byte	Description	Bits	Details
10-11	Version	0 to 5	<i>Reserved</i>
		6 to 8	Product parameter list version
		9 to 15	Product type code: 4 = Compact soft starter 6 = Advanced soft starter
12-13	Device details	0 to 7	<i>Reserved</i>
		8 to 15	Soft starter model ID
14-15	<i>Reserved</i>		
16-17	<i>Reserved</i>		
18-19	Starter state	0 to 4	0 = <i>Reserved</i> 1 = Ready 2 = Starting 3 = Running 4 = Stopping 5 = Not ready (restart delay, restart temperature check, run simulation) 6 = Tripped 7 = Programming mode 8 = Jog forward 9 = Jog reverse
		5	1 = Warning
		6	0 = Uninitialised 1 = Initialised
		7	0 = Remote control (Network) 1 = Local control (Keypad, Digital Input)
		8	<i>Reserved</i>
		9	0 = Negative phase sequence 1 = Positive phase sequence
		10 to 15	See <i>Trip codes</i> on page 15
		20-21	Current
14 to 15	<i>Reserved</i>		
22-23	Current	0 to 9	Current (% motor FLC)
		10 to 15	<i>Reserved</i>

Byte	Description	Bits	Details
24-25	Motor temperature	0 to 7	Motor 1 thermal model (%)
		8 to 15	<i>Reserved</i>
26-27	Power	0 to 11	Power
		12 to 13	Power scale 0 = Multiply power by 10 to get W 1 = Multiply power by 100 to get W 2 = Power (kW) 3 = Multiply power by 10 to get kW
		14 to 15	<i>Reserved</i>
28-29	% Power factor	0 to 7	100% = power factor of 1
		8 to 15	<i>Reserved</i>
30-31	<i>Reserved</i>		
32-33	Current	0 to 13	Phase 1 current (rms)
		14 to 15	<i>Reserved</i>
34-35	Current	0 to 13	Phase 2 current (rms)
		14 to 15	<i>Reserved</i>
36-37	Current	0 to 13	Phase 3 current (rms)
		14 to 15	<i>Reserved</i>
38-39	<i>Reserved</i>		
40-41	<i>Reserved</i>		
42-43	<i>Reserved</i>		
44-45	Parameter list version number	0 to 7	Parameter list minor revision
		8 to 15	Parameter list major version
46-47	Digital input state		For all inputs, 0 = open, 1 = closed (shorted)
		0	Start
		1	Stop
		2	Reset (Refer to note)
		3	Input A
		4 to 15	<i>Reserved</i>
48-49	Trip code	0 to 15	See <i>Trip codes</i> on page 15
50-59	<i>Reserved</i>		
60-63	Parameter management		See <i>Parameter management</i> on page 14



NOTE

The reset input is normally closed by default. If parameter 6M *Remote Reset Logic* is set to normally open, the reported state will be inverted (0 = closed, 1 = open).



NOTE

For models 0053B and smaller, current reported via communications is 10 times greater than the actual value (displayed on the keypad).

6.3 Parameter management

The Profinet Module can read parameter values from and write parameter values to the soft starter. The module handles one parameter at a time.

The device references parameters according to their position in the starter's parameter list.



CAUTION

Changing the values of the Factory parameters (parameter group 20) may cause unpredictable behaviour in the soft starter. Consult your local supplier before adjusting the Factory parameters.

Output

Use output bytes 2-5 to read or write a parameter to the soft starter.

Controller > device output bytes are structured as follows.

Byte	Bits	Details
2	0 to 7	Parameter number to read/write
3	0	<i>Reserved</i>
	1	1 = Read parameter
	2	1 = Write parameter
	3 to 7	<i>Reserved</i>
4	0 to 7	Low byte parameter value to write to soft starter/ zero data values for read
5	0 to 7	High byte parameter value to write to soft starter/ zero data values for read

Input

Parameter data from the starter is reported in input bytes 60-63.

Device > controller input bytes are structured as follows.

Byte	Bits	Details
60	0 to 7	Echo parameter number
61	0	1 = Invalid parameter number
	1	1 = Invalid parameter value
	2 to 7	<i>Reserved</i>
62	0 to 7	Low byte parameter value read from soft starter
63	0 to 7	High byte parameter value read from soft starter

6.4 Trip codes

Trip code	Description
1	Excess start time
2	Motor overload
3	Motor thermistor
4	Current imbalance
5	Frequency
6	Phase sequence
7	Instantaneous overcurrent
8	Power loss
9	Undercurrent
10	Heatsink overtemperature
11	Motor connection
12	Input A trip
13	FLC too high
14	Unsupported option (function not available in inside delta)
15	Starter communication (between device and soft starter)
16	Network communication (between device and network)
17	Internal fault
20	Ground fault
23	Parameter out of range
24	Input B trip
26	L1 phase loss
27	L2 phase loss
28	L3 phase loss
29	L1-T1 shorted
30	L2-T2 shorted
31	L3-T3 shorted
32	Motor 2 overload
33	Time-overcurrent / Bypass overload
34	SCR overtemperature
35	Battery/clock
36	Thermistor circuit
37	RTD/PT100 A
38	RTD/PT100 B
39	RTD/PT100 C
40	RTD/PT100 D
41	RTD/PT100 E
42	RTD/PT100 F
43	RTD/PT100 G
45	RTD/PT100 X Cirtct
46	Analog input trip
255	No trip

6.5 Examples

Control commands (controller to device)

Start the motor using parameter set 1							
Byte 0	Byte 1	Byte 2	Byte 3	Byte 4	Byte 5	Byte 6	Byte 7
4	1						

Start the motor, select via remote input							
Byte 0	Byte 1	Byte 2	Byte 3	Byte 4	Byte 5	Byte 6	Byte 7
0	1						

Stop the motor using the programmed soft stop for motor set 2							
Byte 0	Byte 1	Byte 2	Byte 3	Byte 4	Byte 5	Byte 6	Byte 7
8	0						

Quick stop the motor							
Byte 0	Byte 1	Byte 2	Byte 3	Byte 4	Byte 5	Byte 6	Byte 7
16	0						

Reset a trip							
Byte 0	Byte 1	Byte 2	Byte 3	Byte 4	Byte 5	Byte 6	Byte 7
≤ 28	8						

Status information (device to controller)

Read control status - Ready							
Byte 0	Byte 1	Byte 2	Byte 3	Byte 4	Byte 5	Byte 6	Byte 7
0	1						

Read control status - Running							
Byte 0	Byte 1	Byte 2	Byte 3	Byte 4	Byte 5	Byte 6	Byte 7
		3	0				

Read control status - Tripped, trip code 4 (Current imbalance)							
Byte 0	Byte 1	Byte 2	Byte 3	Byte 4	Byte 5	Byte 6	Byte 7
		6	0	4	0		

Parameter management

Read parameter from advanced soft starter: parameter number 12, 2H Stop Mode							
Byte 0	Byte 1	Byte 2	Byte 3	Byte 4	Byte 5	Byte 6	Byte 7
		12	2	0	0		

Parameter read response: parameter 2H Stop Mode = 1 (TVR Soft Stop)							
Byte 56	Byte 57	Byte 58	Byte 59	Byte 60	Byte 61	Byte 62	Byte 63
				12	0	1	0

7 Network design

The device supports star, line and ring topologies.

7.1 Star topology

In a star network, all controllers and devices connect to a central network switch.

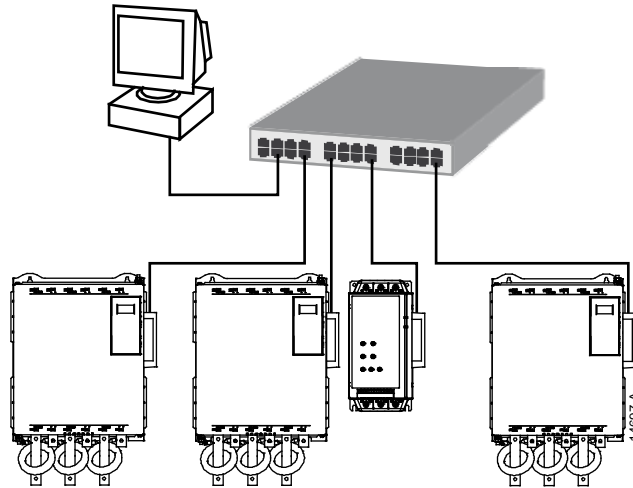

7.2 Line topology

In a line network, the controller connects directly to one port of the first device. The second Ethernet port connects to another device, which in turn connects to another device until all devices are connected.

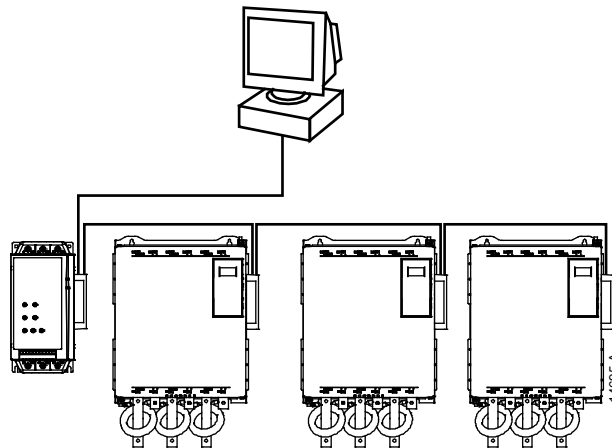

NOTE

The device has an integrated switch to allow data to pass through in line topology. The device must be receiving control power from the soft starter for the switch to operate.



NOTE

If the connection between two devices is interrupted, the controller cannot communicate with devices after the interruption point.



NOTE

Each connection adds a delay to communication with the next device. The maximum number of devices in a line network is 32. Exceeding this number may reduce the reliability of the network.

7.3 Ring topology

In a ring topology network, the controller connects to the first module, via a network switch. The second Ethernet port of the module connects to another device, which in turn connects to another device until all devices are connected. The final device connects back to the switch.

The device supports beacon based ring node configuration.

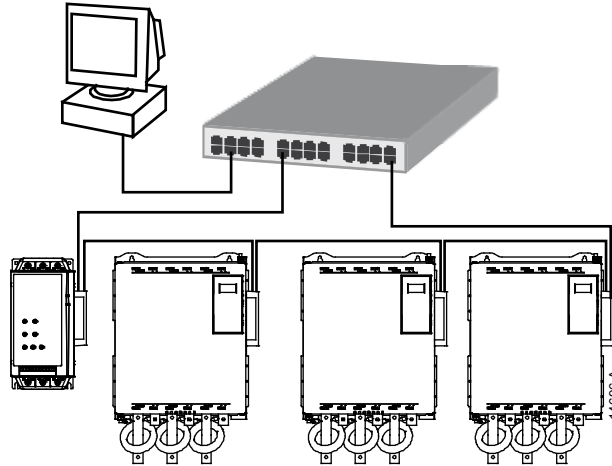

NOTE

The network switch must support loss of line detection.

7.4 Combined topologies

A single network can include both star and line components.

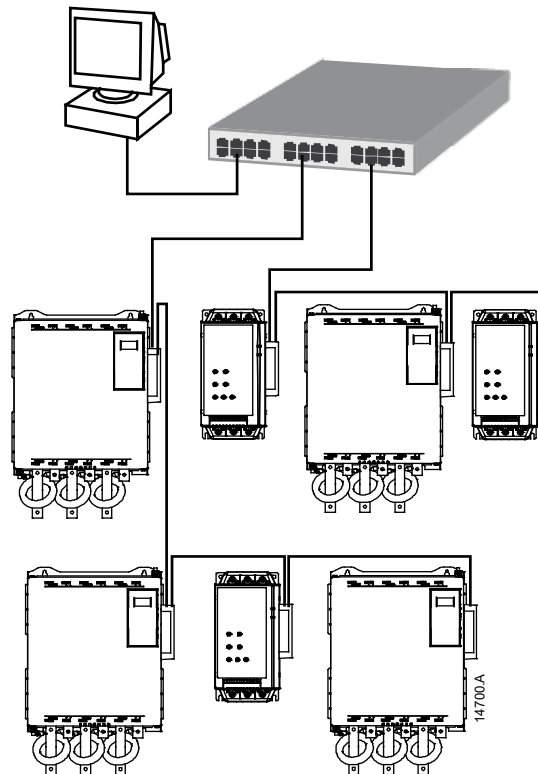

8 Specifications

- **Enclosure**

Dimensions 40 mm (W) x 166 mm (H) x 90 mm (D)

Weight 250 g

Protection IP20

- **Mounting**

Spring-action plastic mounting clips (x 2)

- **Connections**

Soft starter 6-way pin assembly

 Contacts Gold flash

Network RJ45

- **Settings**

IP Address Automatically assigned

Device name Automatically assigned, configurable

- **Network**

Link speed 10 Mbps, 100 Mbps (auto-detect)

Full duplex

Auto crossover

- **Power**

Consumption (steady state, maximum) 35 mA @ 24 VDC

Reverse polarity protected

Galvanically isolated

- **Certification**

CE EN 60947-4-2

Profibus & Profinet International  PROFIBUS · PROFINET

